

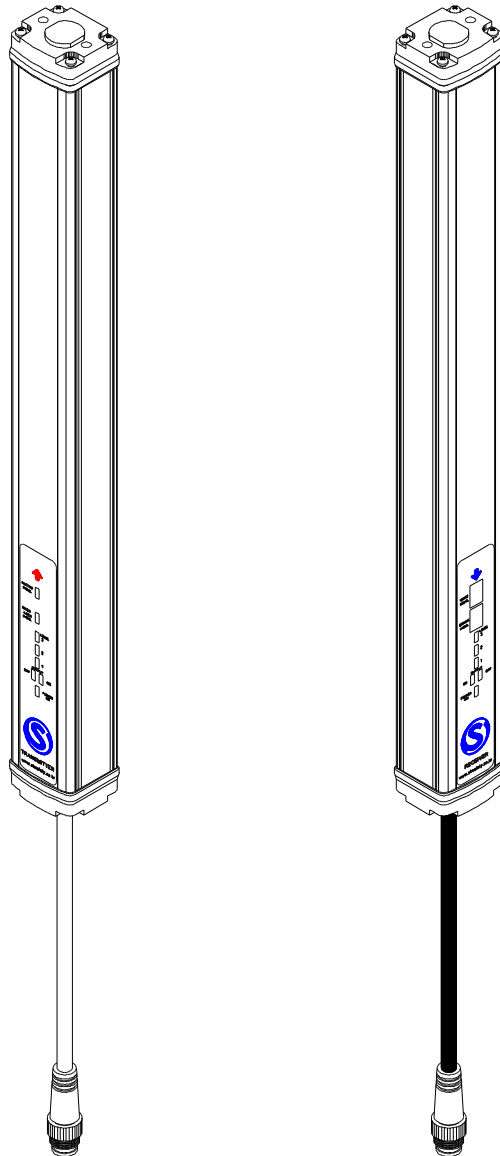

§ **INSTRUCTION MANUAL** §
SAFETY LIGHT CURTAINS



www.sksafety.co.kr

ADDRESS : BLOCK45 LOT6, NAMDONG INDUSTRIAL COMPLEX 435- 6, NONHYUN- DONG,
NAMDONG- GU, INCHEON, KOREA.

■ Instruction Book ■

1. Basic Configuration and Names
2. Component of the Product
3. Indicator Display Patterns
4. System Configuration and Functions
5. Ratings/Specifications
6. System Configuration and Selection Method
7. Explanation of the function operation
 - 1) General Function Operation
 - 2) Reset Function Operation
 - 3) Muting Function Operation
 - 4) Test Function Operation
8. Wiring Diagram for each Functions
9. Installation Example of Standard Muting Mode
10. Override Explanation
11. Installation Conditions
12. Safety Distance
13. Setting Example
14. Dimension & Development Figure
15. External Device Monitoring Function (EDM)

1. Basic Configuration and Names

1-1. Name of the Product

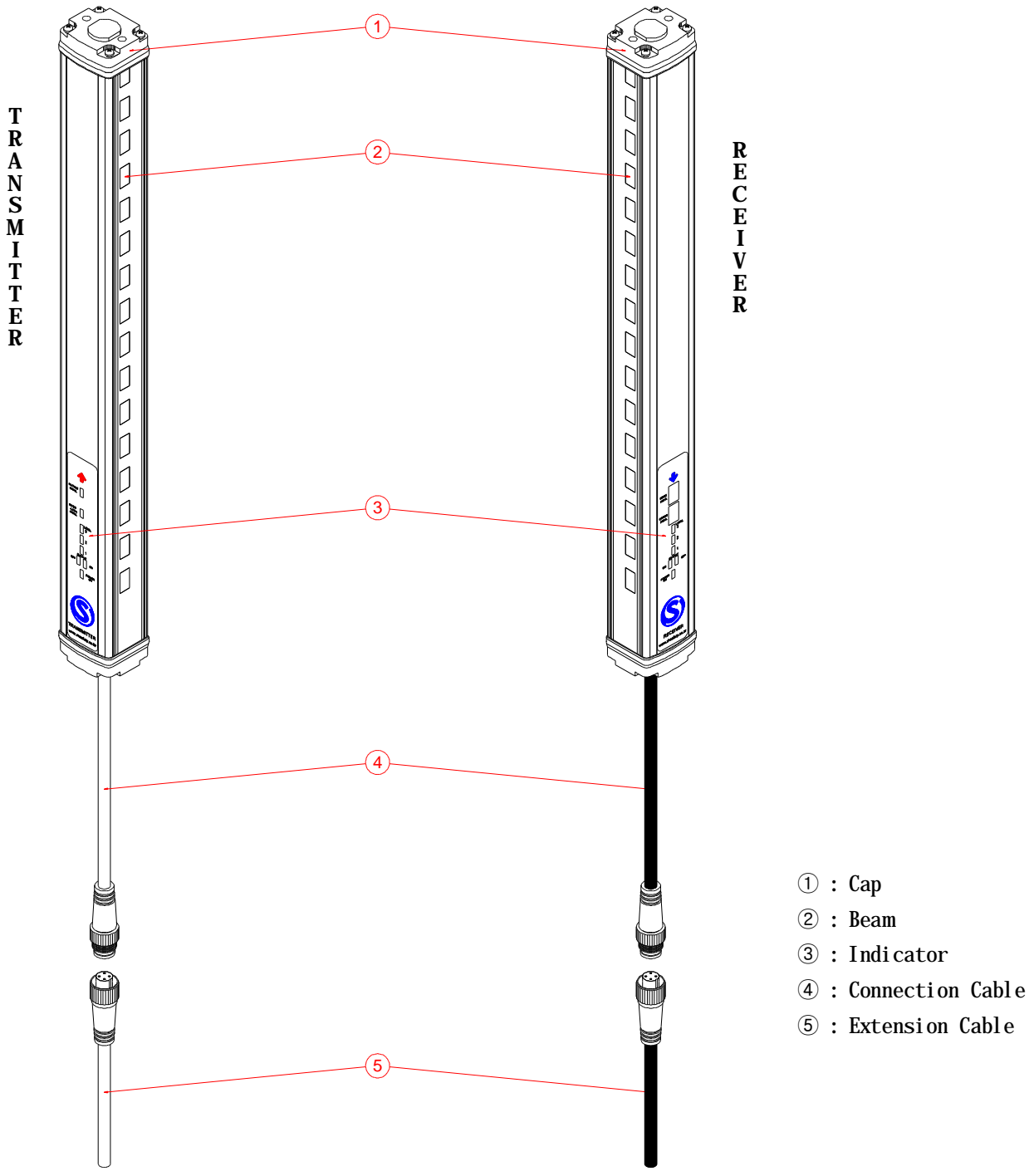

1- 2. Component of the Product

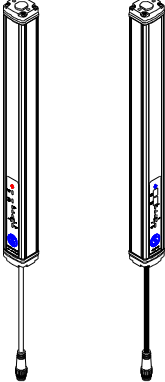
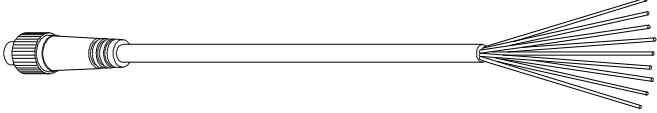
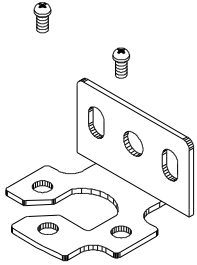



Product	Quantity
<p>SK- S2□□P- □</p>	<p>Transmitter 1 pc , Receiver 1 pc</p> 
<p>SK- JC□A- T(gray) SK- JC□A- R(black)</p>	<p>Cable with connector on one end 1 pc for the Transmitter & Receiver</p> 
<p>SK- BK1</p>	<p>Bracket 4pcs</p> 
<p>Instruction Manual</p>	<p>English 1 pc</p>

1- 3. Model Name List

M O D E L	
1	SK- S212P- □
2	SK- S216P- □
3	SK- S220P- □
4	SK- S224P- □
5	SK- S228P- □
6	SK- S232P- □
7	SK- S236P- □
8	SK- S240P- □
9	SK- S244P- □
10	SK- S248P- □
11	SK- S252P- □
12	SK- S256P- □
13	SK- S260P- □
14	SK- S264P- □

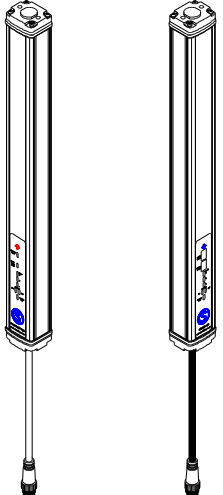
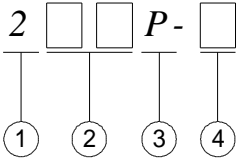
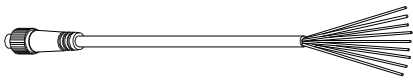
2. Component of the Product

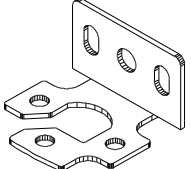
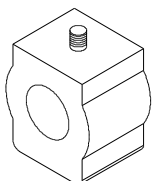
2- 1. Ordering Method

Accessory	Model Name	Explanation
<p>Transmitter, Receiver</p> 	<p>SK- S2□□P- □</p>	<p style="text-align: center;"> $SK - S \quad 2 \quad \square \quad \square \quad P - \quad \square$  </p> <p>① : An optic axis pitch ② : Number of an optic axis ③ : Output type (P=PNP output type) ④ : T is transmitter, R is receiver, Blank is a set of an transmitter and a receiver</p>
<p style="writing-mode: vertical-rl; transform: rotate(180deg);">Extension</p> <p>Cable with connector on one end</p> 	<p>SK- JC□A</p>	<p>This extension cable is used to connect the SK-S2□□P-□ to a controller with discrete terminals or to a safety processing system</p>
<p>Cable with connectors on both ends</p> 	<p>SK- JC□B</p>	<p>This extension cable is used when the length of the connection cable is insufficient or for plug and play connection to the controller.</p>
<p>Top/Bottom fixed bracket</p> 	<p>SK- BK1</p>	<p>Bracket for the fixed sensor</p>
<p>Support Guide</p> 	<p>SK- BG1</p>	<p>Assemble and use with fixed bracket for the support guide</p>
<p>Cap for muting</p> 	<p>SK- M1</p>	<p>Use the SK-M1 for muting function extension</p>

3. Indicator Display Patterns

3- 1. Indicator Explanation

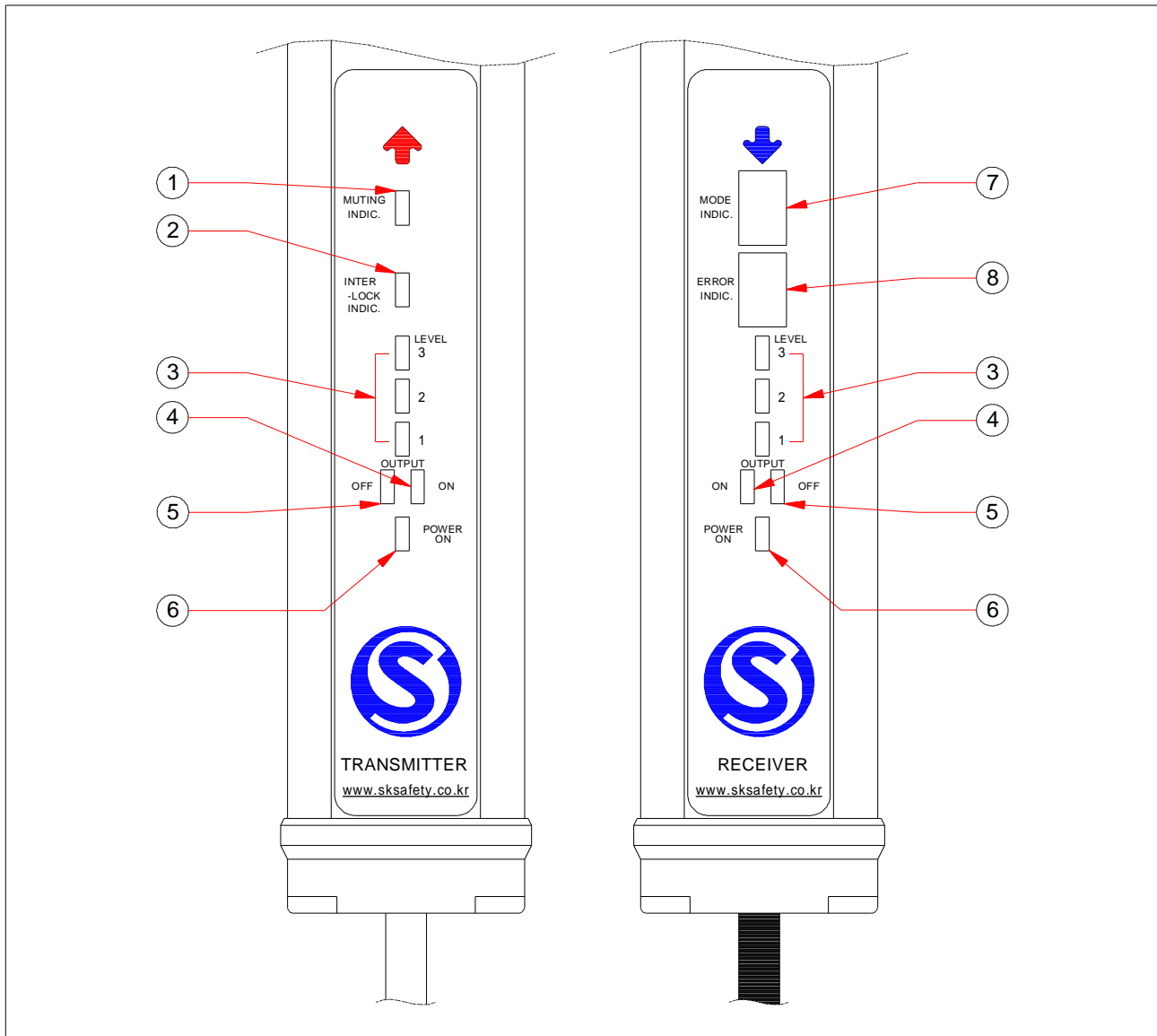

No.	Indicator	Description
1	Muting Indicator	Turns ON when muting function is used
2	Reset Indicator	Turns ON when reset function is used
3	Receiver Level Indicator	Indication status of LEVEL-1 to 3 shows an input states. For details of the receiver level mode, see "Picture-3"
4	ON-State Indicator	Turns ON when safety outputs are ON
5	OFF-State Indicator	Turns ON when safety outputs are OFF
6	Power Indicator	Turns ON when the power is ON
7	Function mode Indicator	Currently function of sensor is indicated by the status of figures. For details of the ability mode, see "Picture-2"
8	Error Mode Indicator	The cause of the error is indicated by the status of figures. For details of the error mode, see "Picture-3"

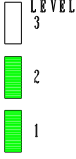
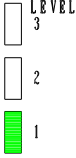
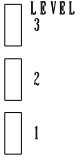

[Picture -1, Receiver Level Indicator]

	<p>Turn on incident light level 1, 2 and 3 when being 120% or higher of control output ON level.</p>
	<p>Turn on incident light level 1 and 2 when being 100~120% of safety output ON level.</p>
	<p>Turn on only incident light level 1 when being 80~100% of safety output ON level.</p>
	<p>Turn off incident light level 1, 2, 3 when being 80% less than of safety output ON level.</p>
<p>Operation is possible with incident light level of 100% or more, but to ensure stability, operate when all incident light level indicators.</p>	

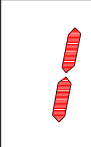
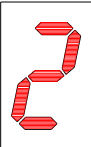
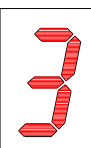
[Picture -2, Ability mode Indicator]

	<p>Turn on when use the general mode If the object disappear from between of the sensor The safety output is turned ON automatically.</p>
	<p>Turn on when use the reset mode. In case of use to the interlock. safety output is keeping OFF until reset input is given when the power is ON and the sensor is interrupted.</p>
	<p>Turn on when use the muting mode. safety function is released temporarily and safety output is keeping ON statuses when the object is interrupted.</p>

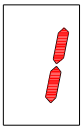
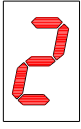
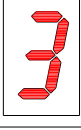
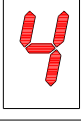
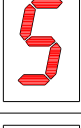
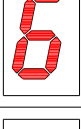
[Picture -3, Error Mde Indicator]

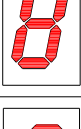
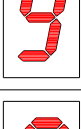
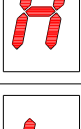
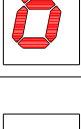
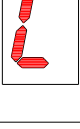
	When the object is detected in between the optical axis, is indicated LED ON ERROR
	when setting and connecting of the optic axis is incorrect is indicated PORT SET ERROR
	At the time of external indicator light defective is indicated MUTE LED ERROR
	When the final output is damaged is indicated. PRA DERR ERROR
	When the final output is damaged is indicated. PRB DERR ERROR
	output a short circuit when input beginning power SAFETY IN ERROR
	When detective of CPU A is indicated. FEED ERROR
	Turn On when a muting error occurs. Muting operation does not working MUTE ERROR
	When input signal constantly is not step by step is indicated. TX PORT ERROR
	At the time of CPU A defective is indicated PRA MONITORING ERROR
	At the time of CPU B defective is indicated PRB MONITORING ERROR
	At the time of emitter and receiver communication defective is indicated PTX ERROR

4. System Configuration and Functions

4- 1. Basic System

Auto Reset , Installation for External Indicator

■ Wiring Diagrams

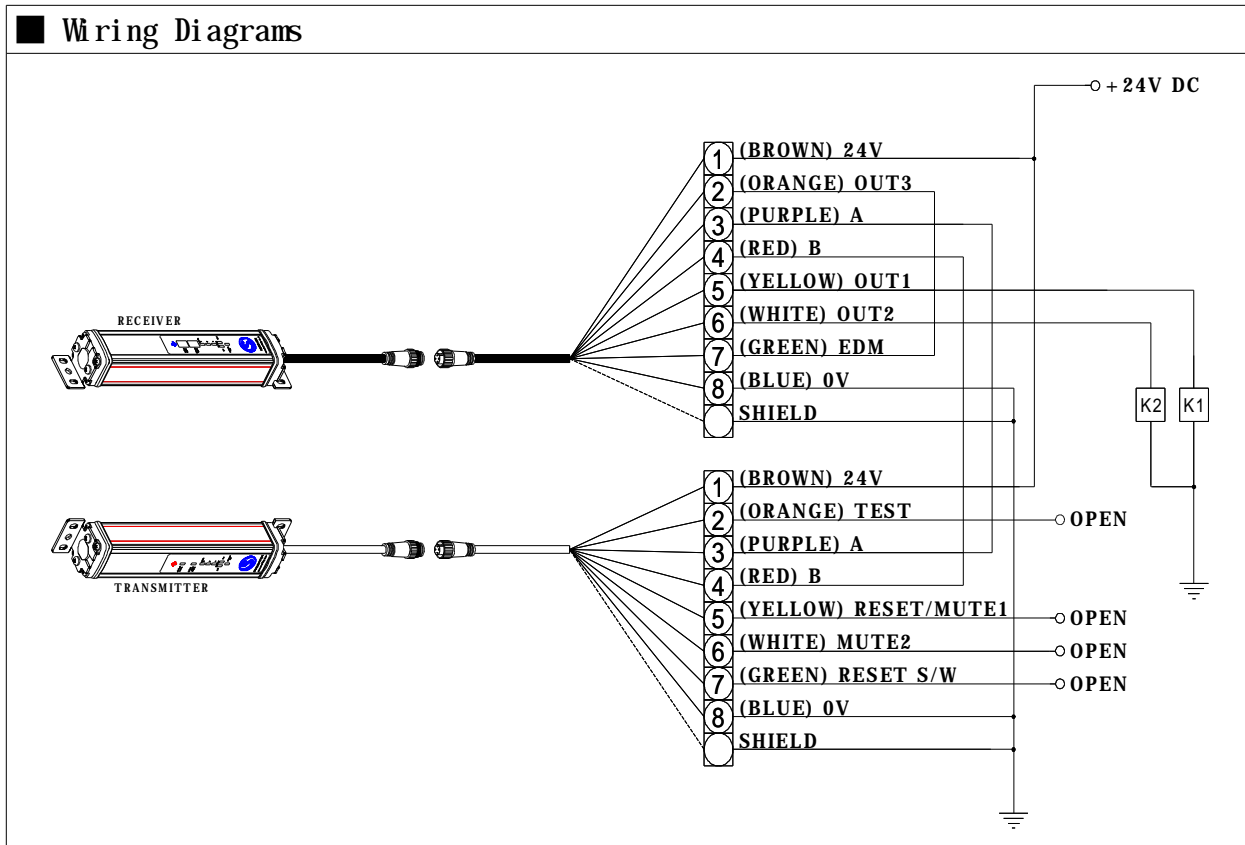

■ Auto Reset

When the interrupting object is removed from the detection zone, the safety outputs automatically turn on.

Auto reset is used on machines where a worker is not able to enter the zone between the detection zone and the hazardous part of the machine in SK-S2□□P.

4-2. Interlock System

Manual Reset , Installation for External Indicator

■ Wiring Diagrams

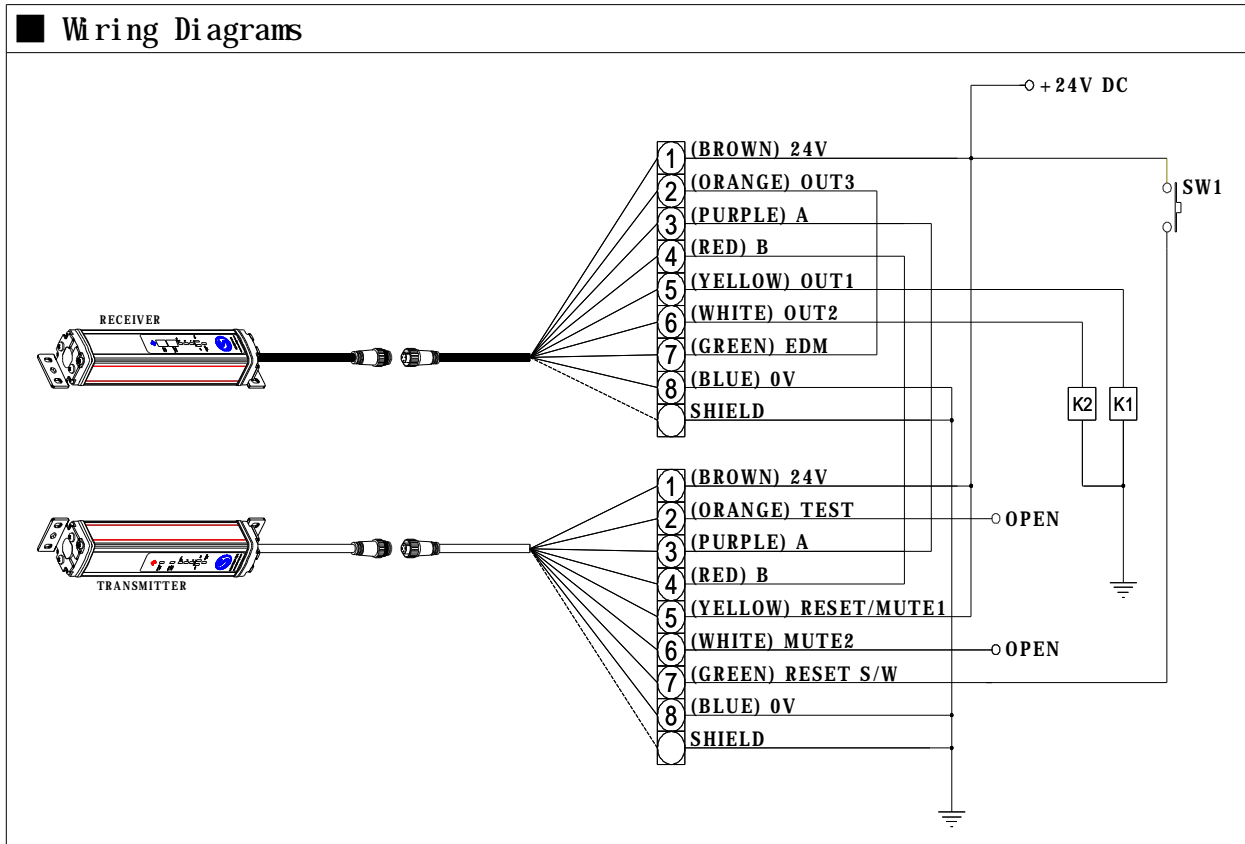

■ Interlock Function

The SK-S2□□P turns the safety outputs OFF when its power is turned on or its beam is interrupted and holds this state until reset input is applied.

This state is called "interlock".

Two methods can be used to reset the interlock state:

"auto reset that automatically turns control outputs ON when the interrupting object is removed" and "manual reset mode that keeps control outputs OFF until a reset signal is provided, if the interrupting object is removed".

■ Manual Reset

When a reset input is given while no interrupting object exists in a detection zone, the safety outputs turn ON. This allows the machine to be manually reset using a reset switch after ensuring safety, preventing unexpected startup (EN1037).

1. The power is turned ON (start interlock)
2. SK-S2□□P is blocked (restart interlock)

※ Use a switch1 for micro loads (Input specifications: DC 24V, 2.5mA)

4-3. Muting System

Muting Function , Installation for External Indicator

■ Wiring Diagrams

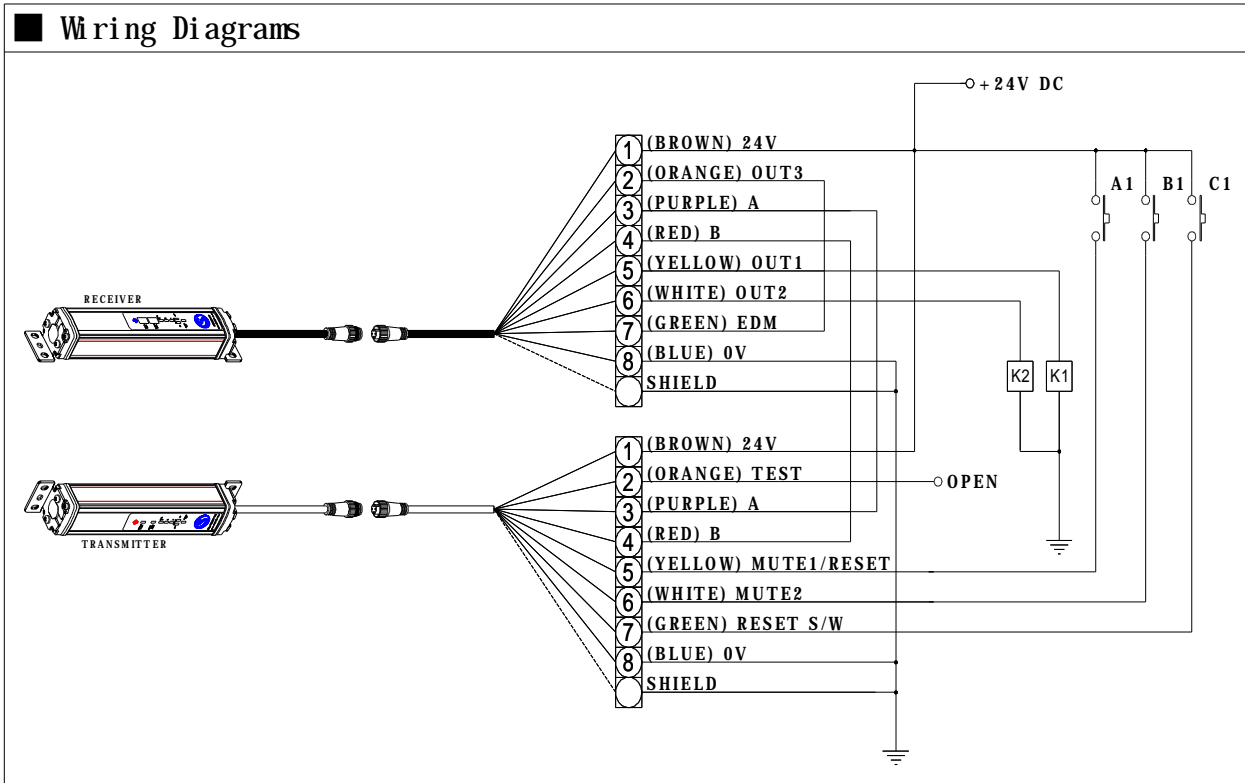

■ Muting Function

The muting function temporarily disables the safety function of the SK-S2□□P, keeping the safety outputs ON even if beams are blocked.

■ Muting lamp connection

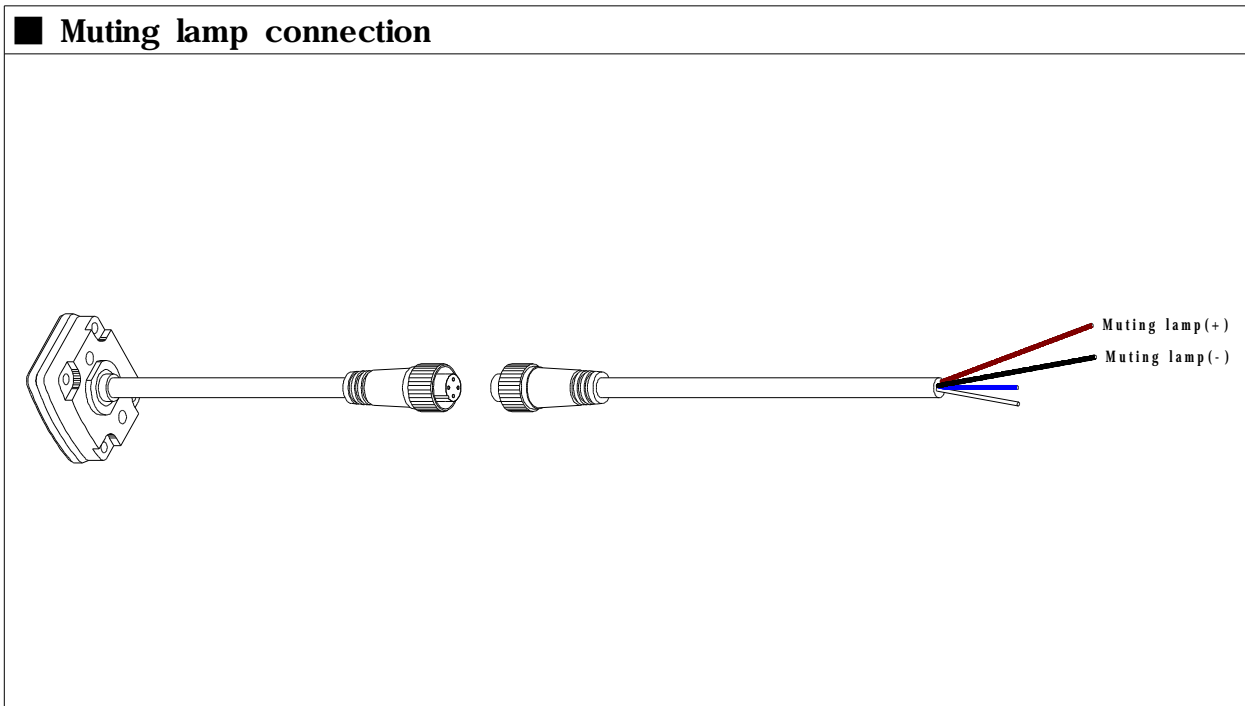

4-4. 테스트 시스템 테스트 기능

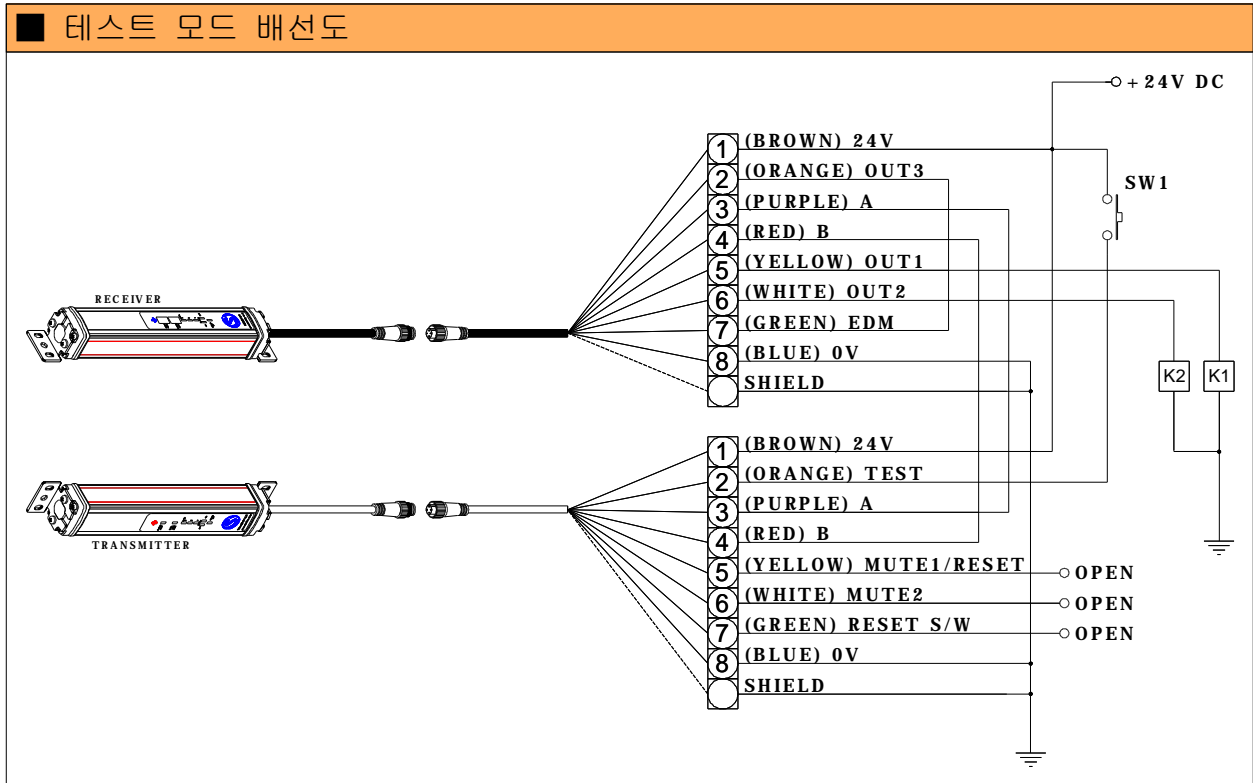

■ 테스트 기능

SW1을 조작시키는 동안에는 SK-S2□□P-T의 투광 기능을 멈추게 하여 수광부에서 제어 출력이 정상적으로 동작하고 있는지를 알아보는 기능입니다. 스위치를 조작할 때마다 차광으로 인식하여 제어출력이 OFF 되면 정상입니다.

5. SPECIFICATION

SK- S2		12P	16P	20P	24P	28P	32P	36P	40P	44P	48P	52P	56P	60P	64P		
Beam gap		20mm															
Lens diameter		12mm× 8mm															
Operating range		0.3 ~ 5m															
Detection capability		32mm(0paque objects)															
Response time		ON→OFF:max 20ms, OFF→ON:max 20ms															
Power supply voltage (Vs)		DC 24V ± 20%															
Current consumption (no load) mA		120	128	135	143	150	158	165	173	180	188	195	203	210	218		
Light source		Infrared LED (830nm)															
Effective aperture angle (EAA)		Within ±2.5° for the emitter and receiver at a detection distance of at least 3 m															
Safety output		PNP transistor outputs(DC 24V) x 2, Load current less than 300mA , Residual voltage less than 2V															
Auxiliary output		NPN transistor output x 1, Load current less than 300mA, Residual voltage less than 2V															
Input voltage		Interlock selection input, reset input, and muting input are all: ON voltage: 11 to 24V (sink current less than 3mA) OFF voltage: 0 to 1.5V , or open															
Indicators	Transmitter	Incident light level indicators (green × 3) Operating indicator(green × 1), Safety indicator(red × 1), Power indicator(green × 1) Reset mode indicator(yellow × 1), Muting indicator(green × 1)															
	Receiver	Operating indicator(green × 1), Safety indicator(red × 1), Power indicator(green × 1), Mode state indicator(1)															
Safety-related functions		Start interlock, restart interlock, Muting (Includes override function)															
Protection circuit		Output short-circuit protection, and power supply reverse polarity protection															
Ambient operating temperature		During operation: -10 to 55° C (without freezing)															
Ambient operating humidity		During operation: 35 to 85%RH (no condensation)															
Ambient light intensity		Incandescent lamp: receiving-surface light intensity of 3,000 Ix less than, Sunlight: receiving-surface light intensity of 10,000 Ix less than.															
Insulation resistance		20MΩ or higher															
Dielectric strength voltage		AC 1, 000V, 50/60Hz, 1min															
Degree of protection		IP65															
Applicable standards		KS C IEC 61496-1 Class 4															
Vibration resistance		Malfunction: 10 to 55Hz, Multiple amplitude of 0.7mm, 20 sweeps each in X, Y, and Z directions															
Shock resistance		Malfunction: 100m/s ² , 1,000 times each in X, Y, and Z directions															
Material		Case: Aluminum(Silver liquid coating) Bracket: HR(Nickel plating) Optical cover: Acrylic Cap: ABS resin															
Weight (g)		715	860	1005	1150	1295	1440	1585	1730	1875	2020	2165	2310	2455	2600		
Accessories		Operating Manual															
MTTFd		223 years				PL				e				CCF		80 Point	
PFHd/h		6.33E-09				SIL				3							
Category		4				DC				99%							

6. System Configuration and Selection Method

■ System Selection

The system is composed according to the function.

Basic system ----- The system which does not use muting.

Interlock system ----- The system which does not use muting.

Muting system ----- The system which does not use interlock.

■ Table of Function

Function		Product delivery of goods from a warehouse condition	Muting system
Interlock function	Auto reset	0	Available
	Start , Restart interlock	0	Unavailable
Auxiliary output		0	Available
External indicator output		0	Available
Muting function		X	Available
Override function		X	Available

7. Explanation of the function operation

7-1. General Function Operation

■ Transmitter

POWER ON LED(⑥), OUTPUT ON LED(④) are turning ON,
 Three of LEVEL LED(③-1:GRREN, ③-2:GREEN, ③-3:GREEN) is turning On at the same time
 transmitter is shown in running order with 100% of an optic axis is formed.

■ Receiver

POWER ON LED(⑥), OUTPUT ON LED(④) are turning ON,
 Three of LEVEL LED(③-1:GRREN, ③-2:GREEN, ③-3:GREEN) is turning On at the same time
 receiver is shown in running order with 100% of an optic axis is formed MODE (⑦)
 Indication must indicate by "1" (Normal mode), From this time being operated
 normally, there is a possibility of knowing.

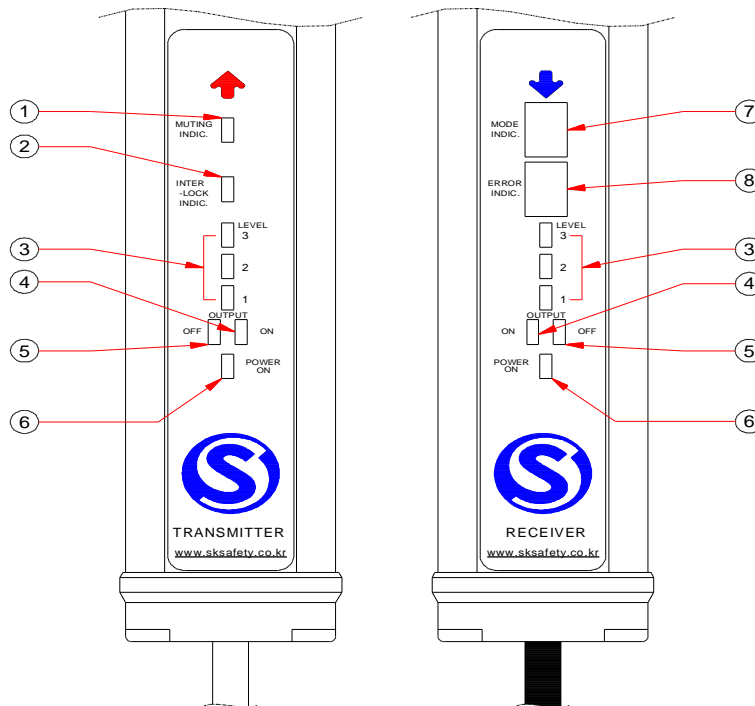

■ General Operation Monitoring SK-S2□□P

General operating is turning OFF When the interrupting object enters from detection zone of the SK-S2□□P When the interrupting object is removed from the detection zone, the safety outputs automatically turn on.

When the interrupting object is detected at this time transmitter and receiver is turning OFF the LEVEL LED(③)OUTPUT LED OFF(⑤) is turning ON and then ERROR(⑧)is indicated "1"

7-2. Reset Function Operation

■ Transmitter

POWER ON LED(⑥), OUTPUT ON LED(④), RESET LED(②) are turning ON,
 Three of LEVEL LED(③-1:GRREN, ③-2:GREEN, ③-3:GREEN) is turning On at the same time
 transmitter is shown in running order with 100% of an optic axis is formed.

■ Receiver

POWER ON LED(⑥), OUTPUT ON LED(④) are turning ON,
 Three of LEVEL LED(③-1:GRREN, ③-2:GREEN, ③-3:GREEN) is turning On at the same time
 receiver is shown in running order with 100% of an optic axis is formed.
 MODE (⑦) Indication must indicate by "2" (Reset mode),
 From this time being operated normally, there is a possibility of knowing.

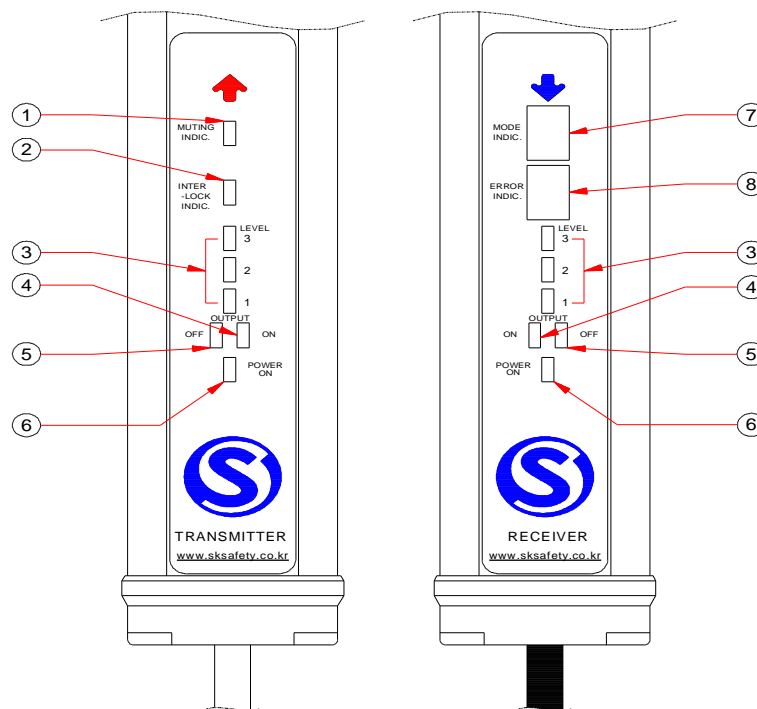

■ Reset function operating is turning OFF When the interrupting object enters from detection zone of the SK-S2□□P if the interrupting object is removed from the detection zone, you must turn ON the reset switch because the safety outputs is not automatically return to normal.

The state of the Interlock is turning ON part of the emitter and receiver in
 OUTPUT LED OFF(⑤) Indicator of MODE(⑦) is shown "2"and then ERROR(⑧)is
 indicated "1"

7- 3. Muting Function Operation

■ Transmitter

POWER ON LED(⑥), OUTPUT ON LED(④), MUTING MODE LED(①) are turning ON,
 Three of LEVEL LED(③-1:GRREN, ③-2: GREEN, ③-3: GREEN) is turning On at the same time
 transmitter shown running order with 100% of an optic axis is formed.

※Muting LED(①) is turning ON with muting operating and is turning OFF with muting cancellation.

■ Receiver

POWER ON LED(⑥), OUTPUT ON LED(④) are turning ON,
 Three of LEVEL LED(③-1:GRREN, ③-2: GREEN, ③-3: GREEN) is turning On at the same time
 receiver is shown in running order with 100% of an optic axis is formed MODE (⑦)

Indication must indicate by "3" (Muting mode),

From this time being operated normally, there is a possibility of knowing.

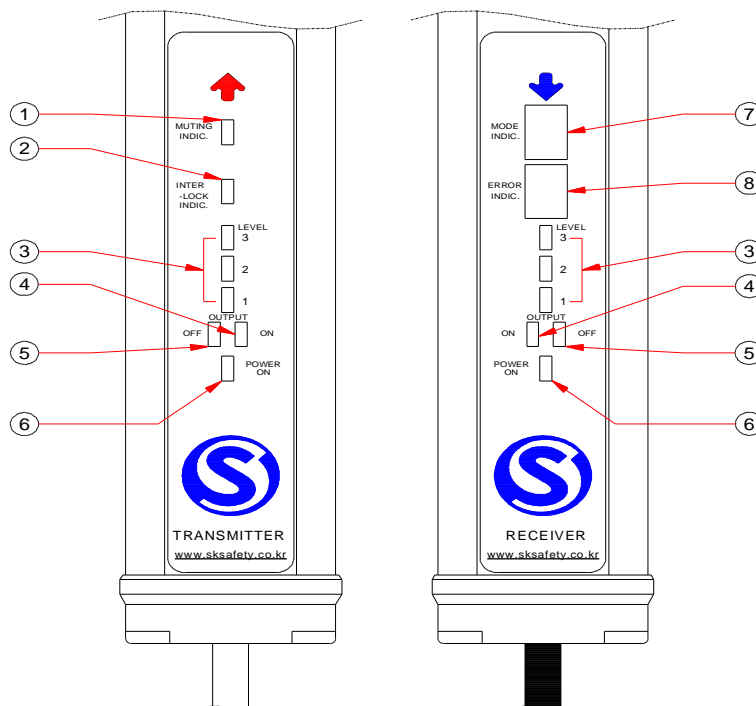

8. Timing Chart

8- 1. Timing Chart for Basic Mdb

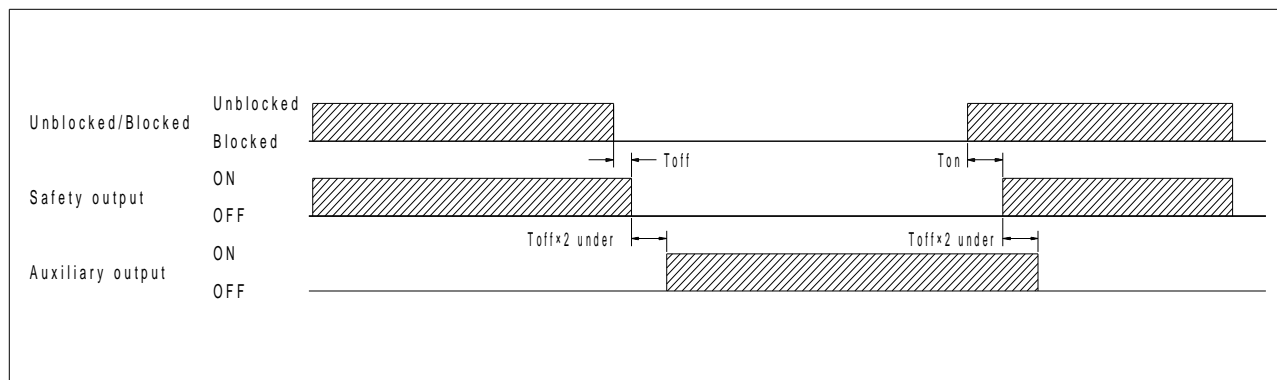

Ton : Response time of safety output's OFF to ON

Toff : Response time of safety output's ON to OFF

Auxiliary output : Provide an inverted signal of the safety output

8- 2. Timing Chart for Reset Mdb

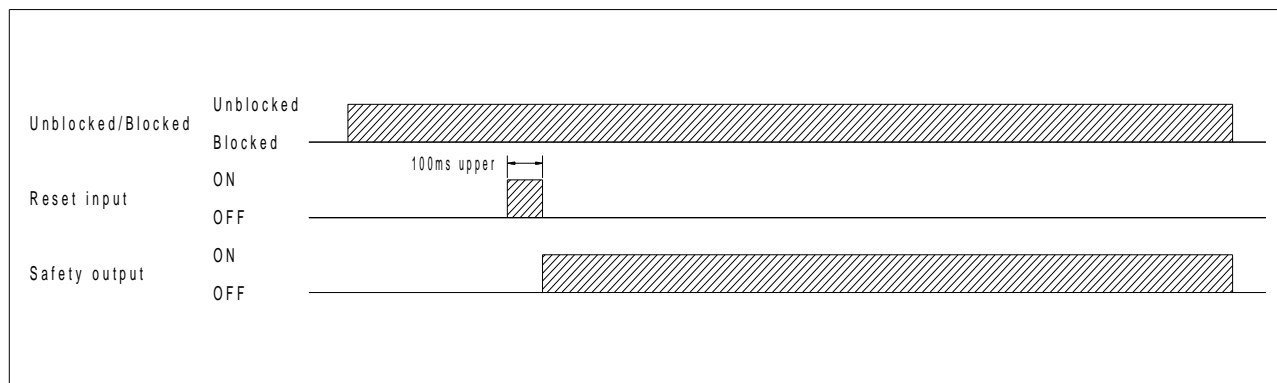

■ Start Interlock

SK-S2□□P enters interlock after power is turned ON

SK-S2□□P is working normally when reset switch push with 100 m/s or higher.

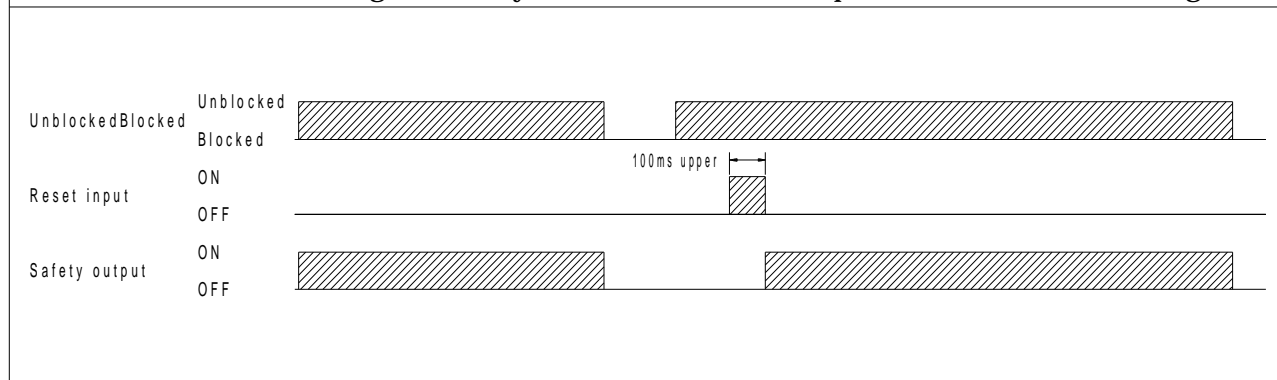

■ Restart Interlock

SK-S2□□P enters interlock state only when the sensor is interrupted.

SK-S2□□P is working normally when reset switch push with 100 m/s or higher.

8- 3. Timing Chart for Muting Mde

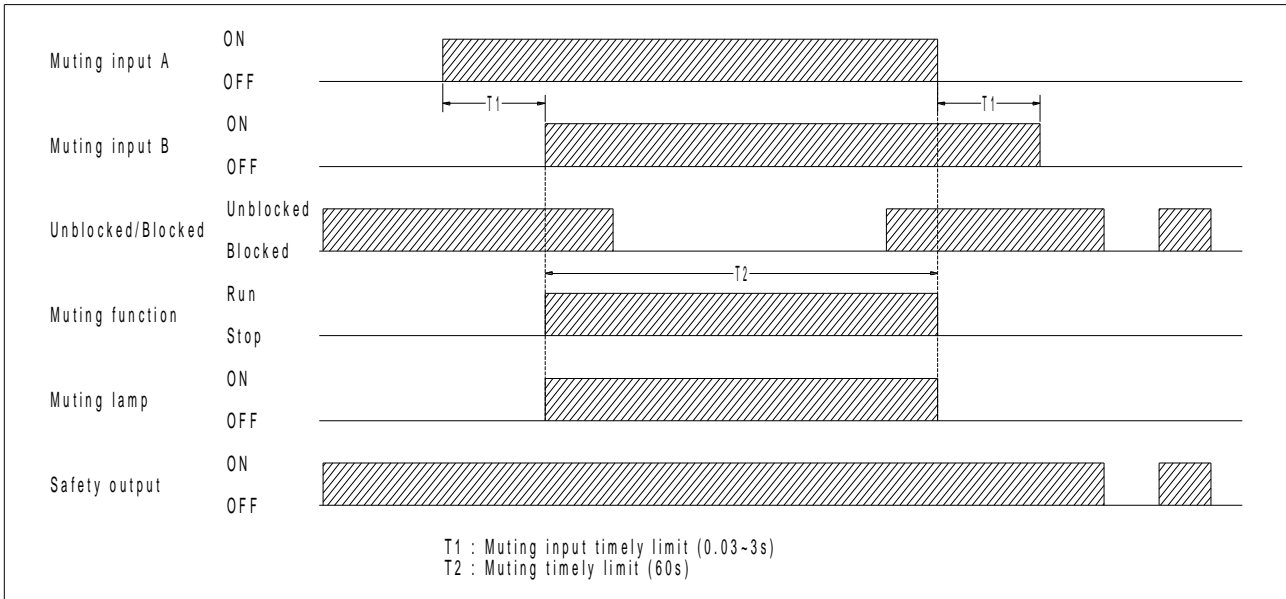

9. Installation Example of Standard Muting Mode

9- 1. Using 4 muting sensors

① Before an object passes through

- ☞ All muting sensors are turned OFF and the safety function of the SK-S2□□P is working.

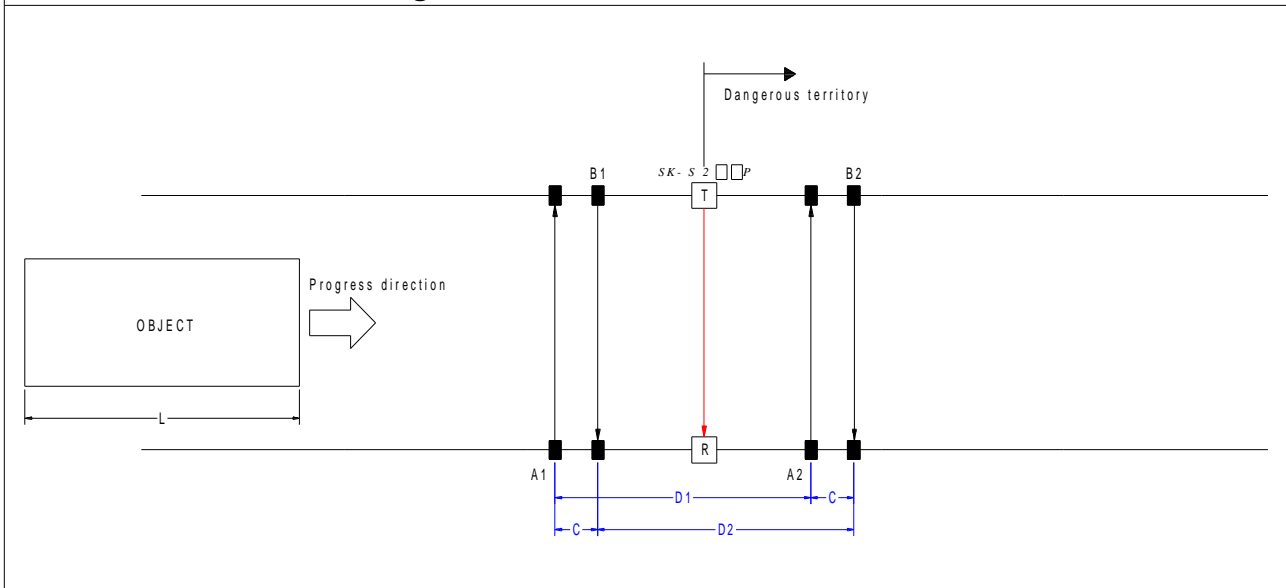

② When muting sensors A1 is turned ON

- ☞ The muting sensors are blocked and B1 is turned on within 3s so the muting function is working.
- ☞ A muting error occur when A1 is turned ON and B1 is turned OFF if muting status exceeds 3s

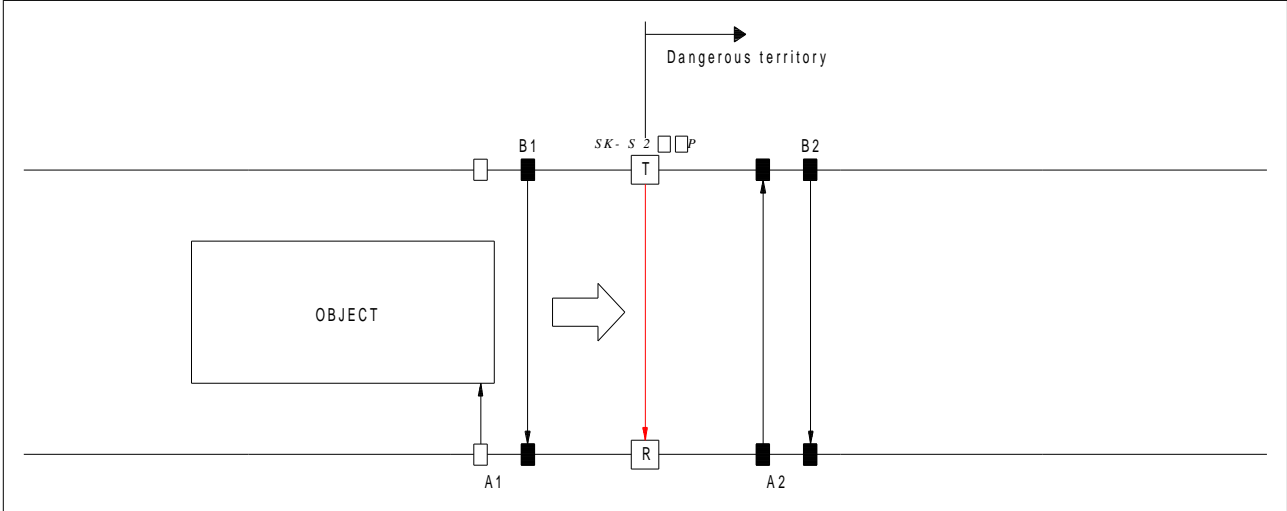

③ When muting sensors A1 and B1 are turned ON

- ☞ The muting function is released, the muting function of the SK-S2□□P is enabled.

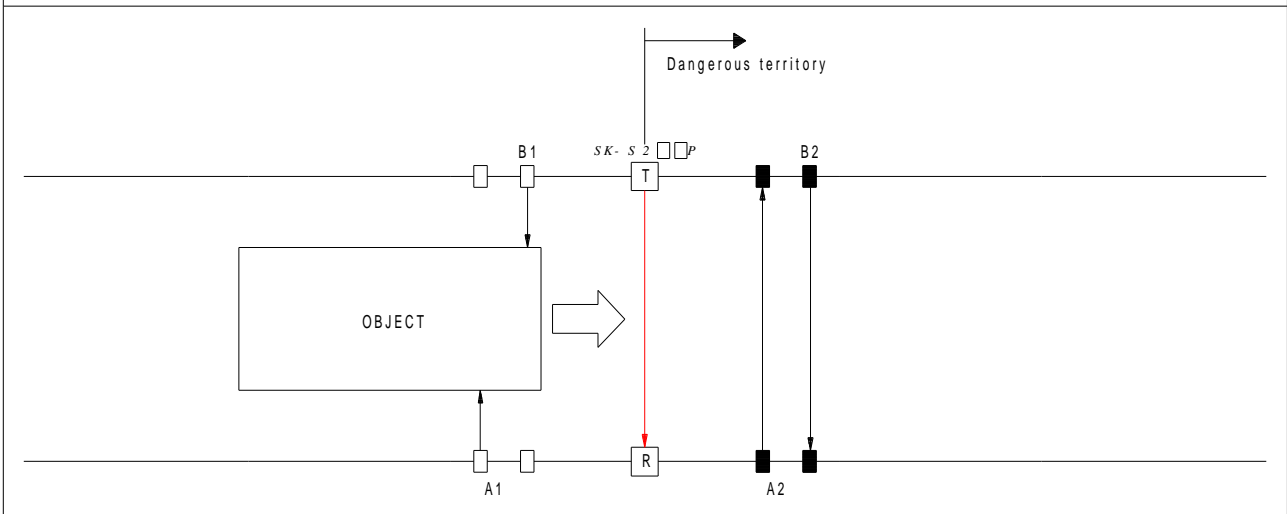

④ According to muting sensors A1 and B1 SK-S2□□P is released and the object passes through all muting sensors.

☞ Muting output is turned ON when the object is interrupted between of SK-S2□□P. (The muting continuation time limit is up to 60sec)

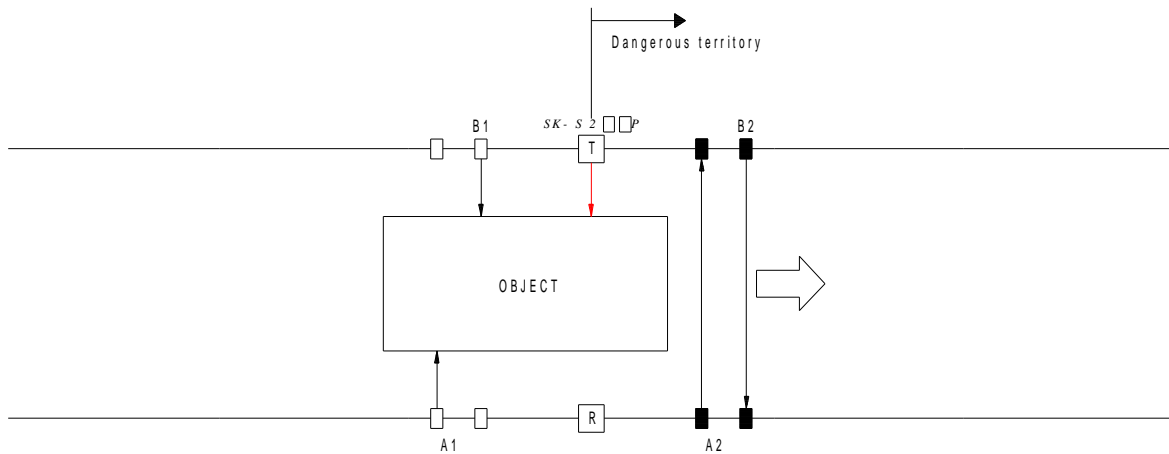

⑤ Muting sensors A1, B1 and A2 are turned ON and the muting function is working.

☞ Muting output is turned ON when the object is interrupted between of SK-S2□□P. (The muting continuation time limit is up to 60sec)

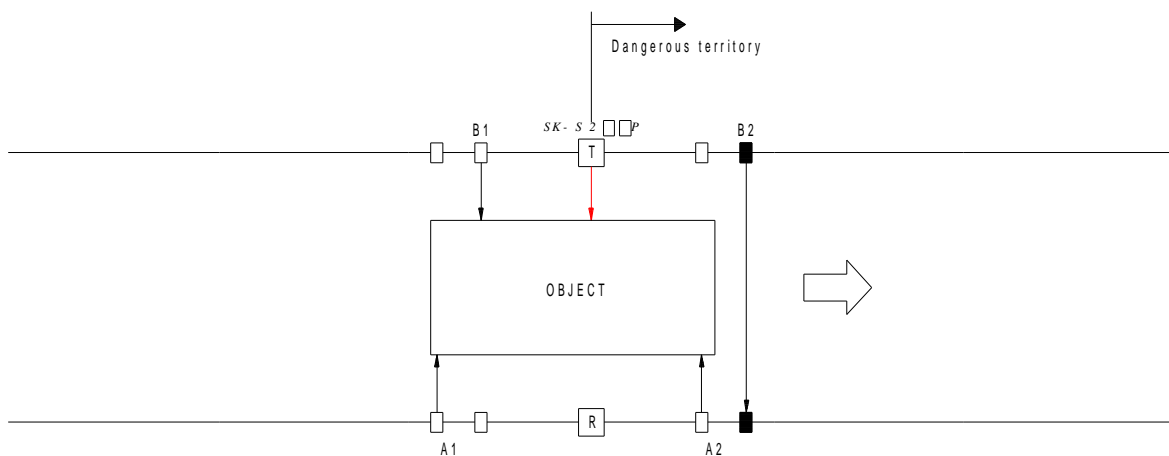

⑥ Muting sensor A1 is turned OFF and SK-S2□□P is released state according to B1, A2.

☞ Muting output is turned ON when the object is interrupted between of SK-S2□□P. (The muting continuation time limit is up to 60sec)

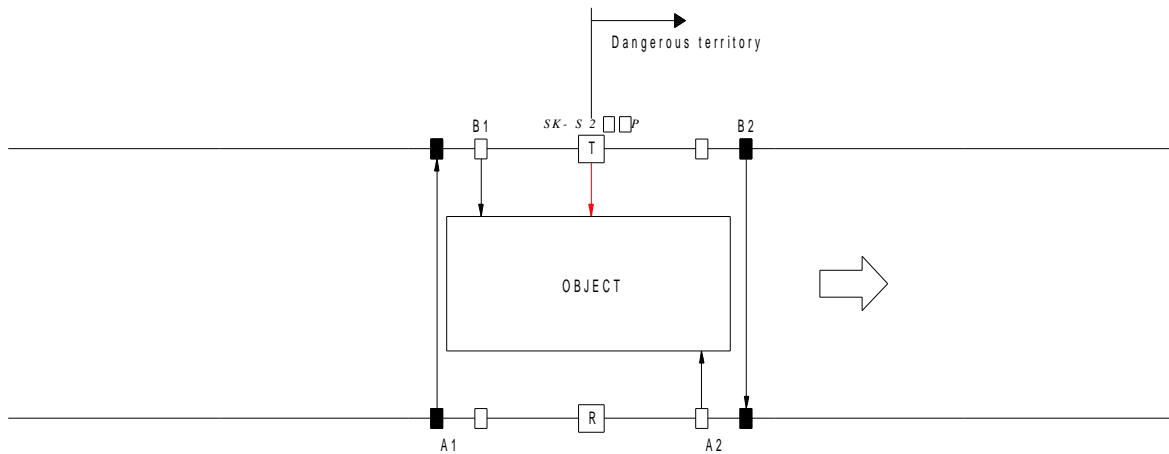

⑦ Muting sensor A1 is turned OFF and SK-S2□□P is released state according to B1, A2 and B2.

☞ Muting output is turned ON when the object is interrupted between of SK-S2□□P. (The muting continuation time limit is up to 60sec)

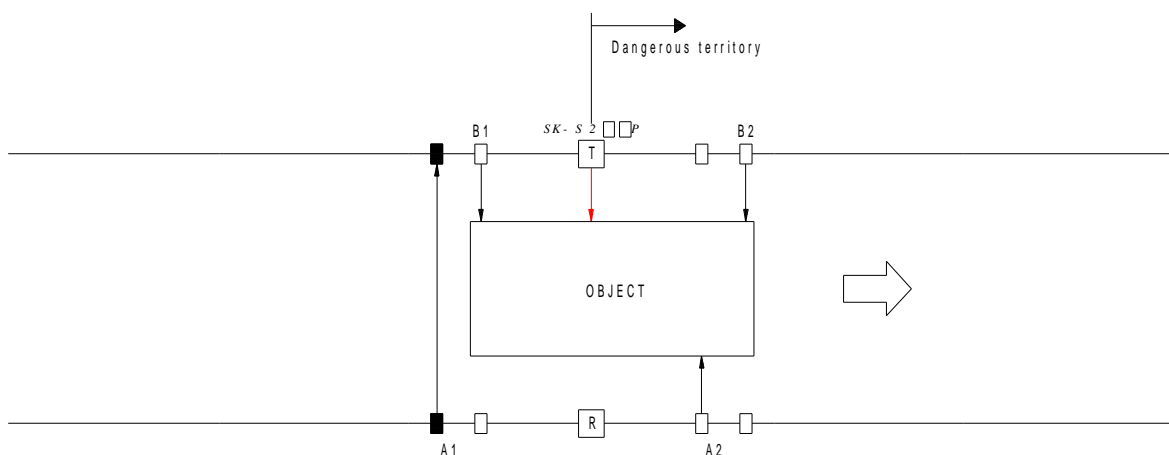

⑧ Although muting sensor A1 and B1 are turned OFF and SK-S2□□P is released state according to A2 and B2.

☞ Muting output is turned ON when the object is interrupted between of SK-S2□□P. (The muting continuation time limit is up to 60sec)

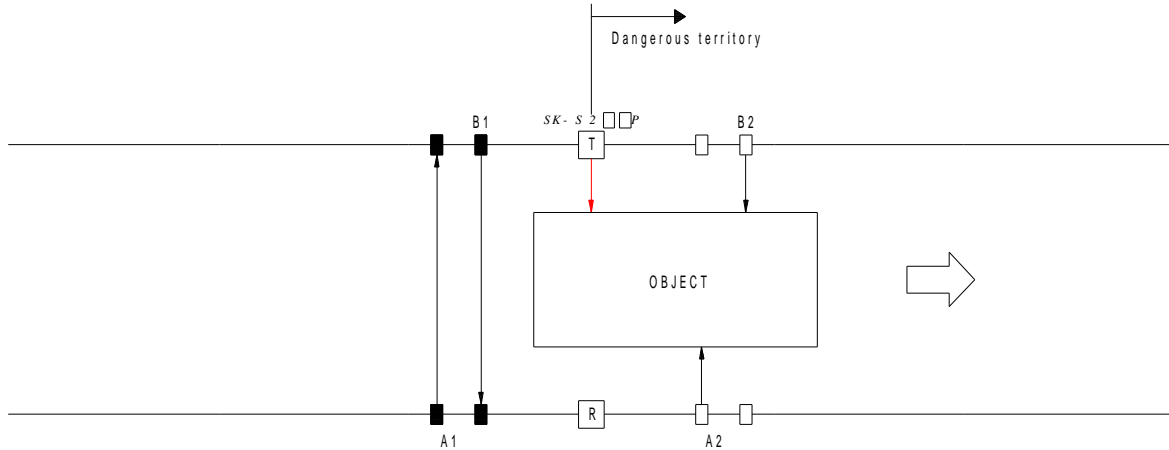

⑨ The object passes through SK-S2□□P and the muting function is keeping state according to A2 and B2.

☞ Muting output is turned ON when the object is interrupted between of SK-S2□□P. (The muting continuation time limit is up to 60sec)

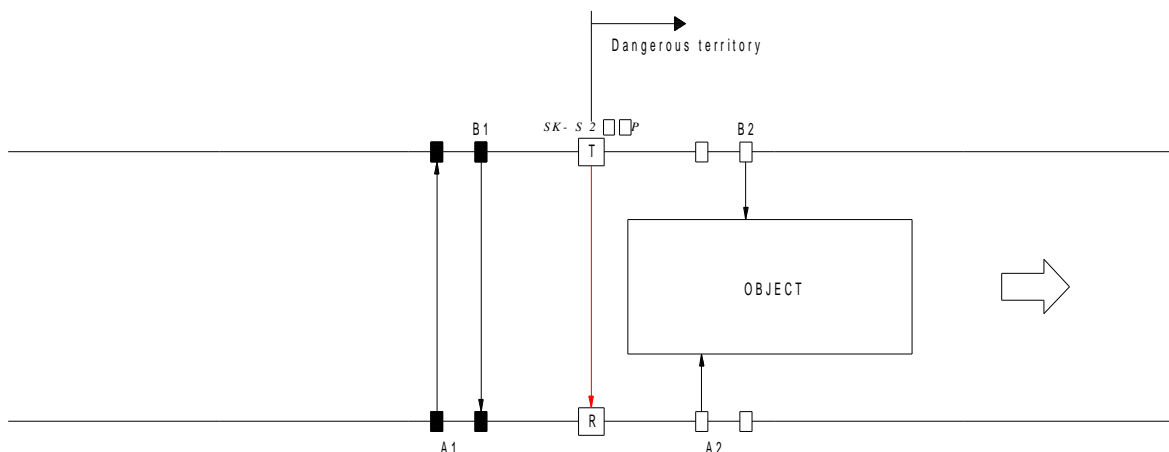

⑩ Muting sensor A2 is turned OFF and Muting function is released state.

☞ SK-S2□□P is working normally.

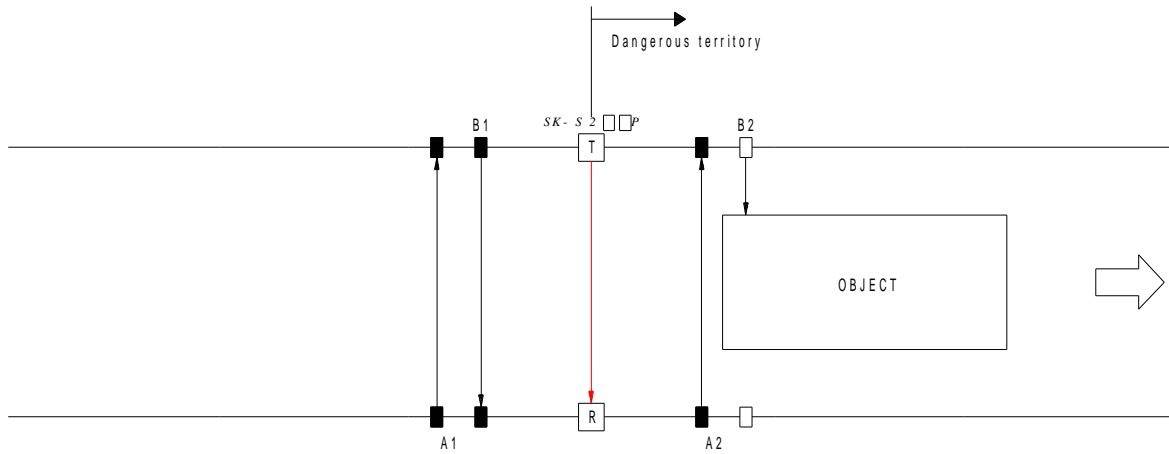

⑪ All muting sensors are turned OFF

☞ Muting output is turned OFF when the object is interrupted between of SK-S2□□P.

☞ The muting sensor A2 is turned OFF and Muting error occurs when B2 is turned ON status during exceeds 3sec.

☞ Object A passes through muting sensor and object B is approaching.

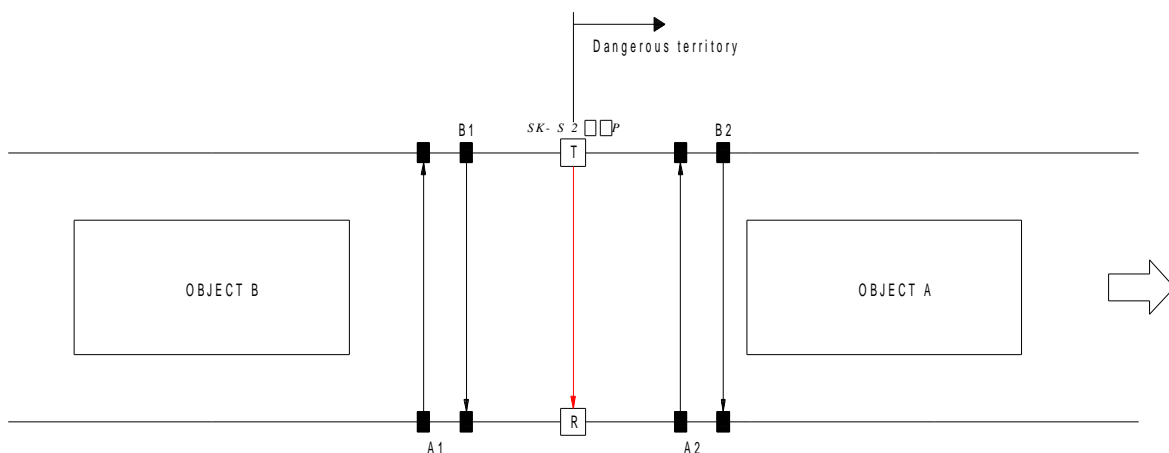

9- 2. Muting conditions

■ Preparations for muting operation

1. Open the end cap of transmitter of SK-S2□□P and replace it with the cap for muting.

■ Start Conditions

1. No interrupting object is found in the SK-S2□□P's detection zone.
2. Safety outputs are ON
3. Incident light level indicator 7 of light projector of SK-S2□□P must be turned On.

■ Start Muting

1. After muting input 1 is turned ON, muting input 2 is turned ON within the muting input time limit of T_{min} to T_{max} (0.03 to 3s).
2. Muting is keeping as the muting input time limit of T2 after muting is started.
3. Before the muting continuation time exceeds the muting time limit of T2 muting input 1 and 2 must be turned OFF within T1(0.03 to 3s).

■ Installation Standard for Muting Sensor

1. Set the muting sensors so that they can detect all of the passing detection objects
(To pass in the direction of the longest length is detected)
2. Install the SK-S2□□P and muting sensors so that each object passes through all muting sensors before the next object arrives at the first muting sensor.
(it means the objects passes through completely or muting is released)

Warning ! Please do not enter the dangerous zone with carelessness while muting function is working

9- 3. Setting Change

■ For muting system

1. Remove the end cap of transmitter. (driver comes with key cap for muting)
2. Attach the key cap for muting to the transmitter.
3. Install a muting lamp (external indicator) on either the transmitter.

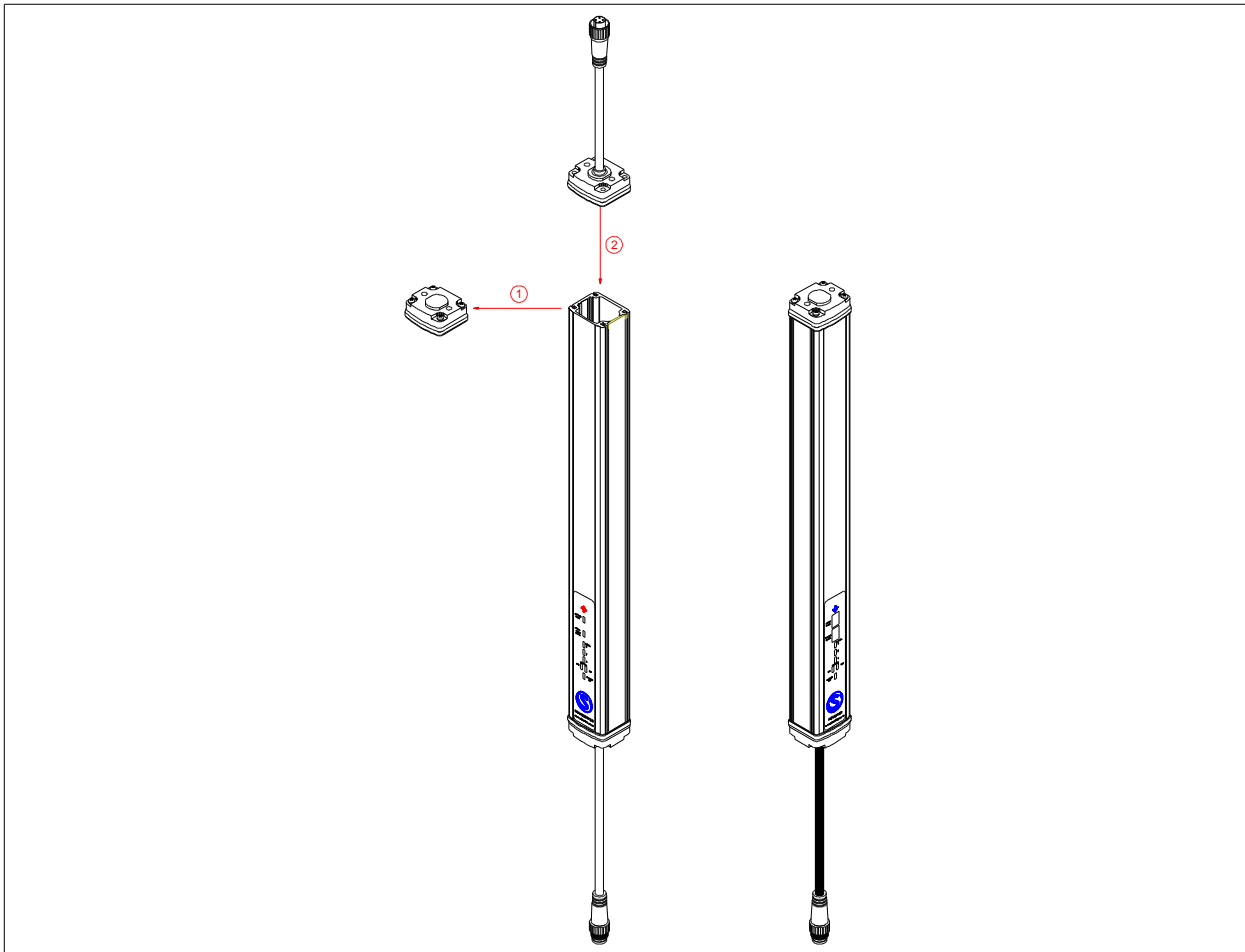

■ Muting Sensor

The muting sensor is the sensor that is the trigger for temporarily disabling the SK-S2□□P's safety functions. Through-beam or recur-reflective photoelectric sensors, proximity sensors, or limit switches can be used as muting sensors.

Warning ! muting sensor's power connect the same like the SK-S2□□P's supplied power.

■ Muting Lamp (External Indicator)

Because it notifies workers that the muting function is operational, the muting lamp (external indicator) must be installed.

Warning ! Use to Muting Lamp (External Indicator) by DC 24V(5W)

9- 4. Installation Distance

The maximum distance, D1, D2, required for muting sensors to keep the muting function enabled is

$$D1 < L \quad \text{-----} \quad \text{Formula (1)}$$

$$D2 < L \quad \text{-----} \quad \text{Formula (2)}$$

L : Length of an object

The maximum distance, C, required for muting sensors to keep the muting function enabled is

$$V \times T1 \text{ min} < C < V \times T1 \text{ max} \quad \text{-----} \quad \text{Formula (3)}$$

V : Approach speed of an object

T1 min : Muting input time limit value (minimum). 0.03s

T1 max : Muting input time limit value (maximum). 3s

To enable the muting function, D1, D2 and C must satisfy formulas (1), (2), and (3) respectively.

9- 5. Wiring Diagram

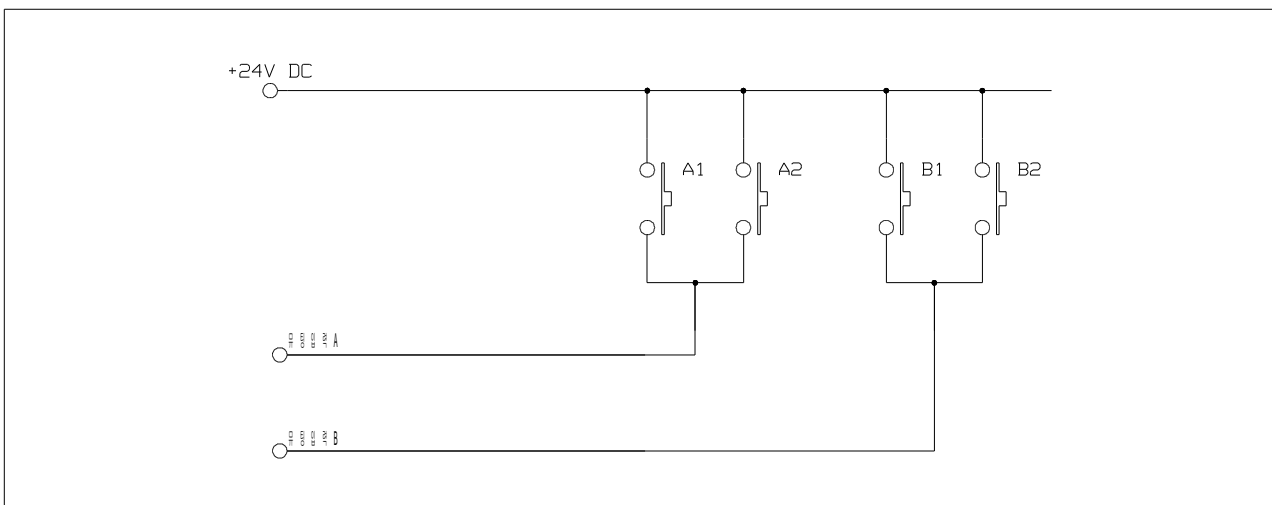

10. Override Function

The override function forcibly turns the safety outputs ON when the muting start condition is not satisfied. If a object stops while passing through the detection zone of the SK-S2□□P, as shown below, causing a muting error, the normal state cannot be recovered unless the object is removed from the muting sensors and the detection zone of the SK-S2□□P.

■ Occurrence Condition of Muting Function Error

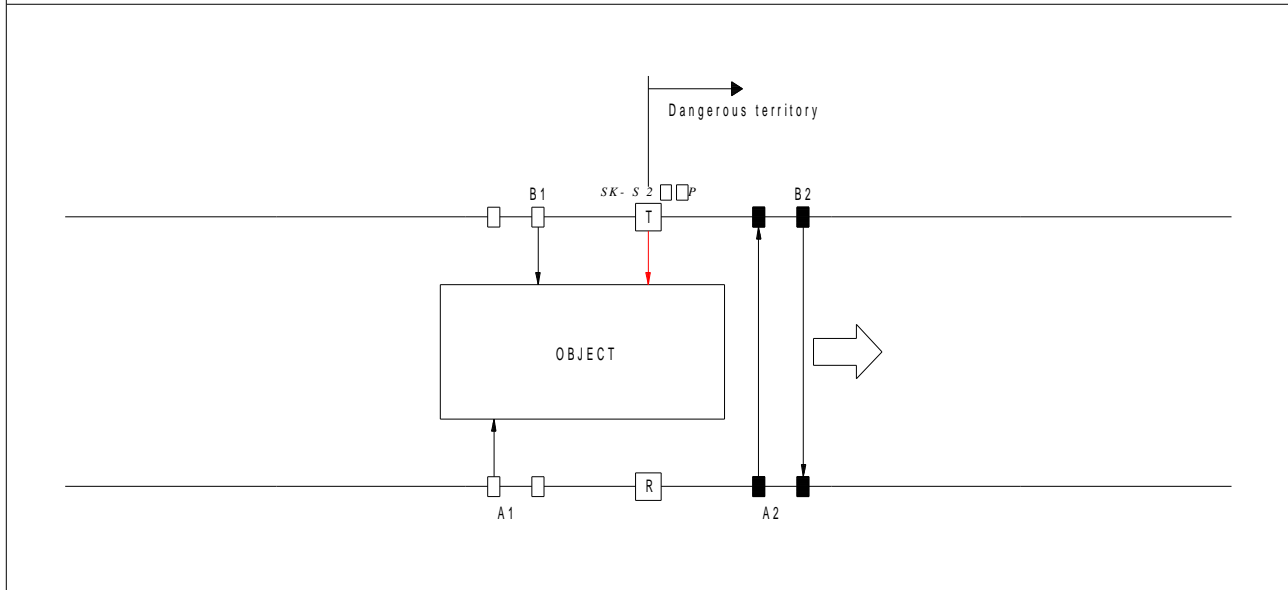

However, the override function will mute the safety outputs of the SK-S2□□P so that the conveyor can be restarted to move the object out of the muting sensors and SK-S2□□P detection zone.

※ The override function can be kept for up to 60s.

The muting lamp (external indicator) blinks while overriding.

Override Function applied while reset's button turning on.

Warning !

The muting and override functions disable the safety functions of the device. You must ensure safety using other method when these functions are operating.

Install the switch that uses hold-to-run device such as a spring-return key switch and is installed in a location that provides a clear view of the entire hazardous zone and where it cannot be activated from within the hazardous zone.

Make sure that nobody is in the hazardous zone before activating the override function. Override time must be properly configured for its application by a sufficiently trained and qualified person.

■ Wiring Diagrams for the Override Function

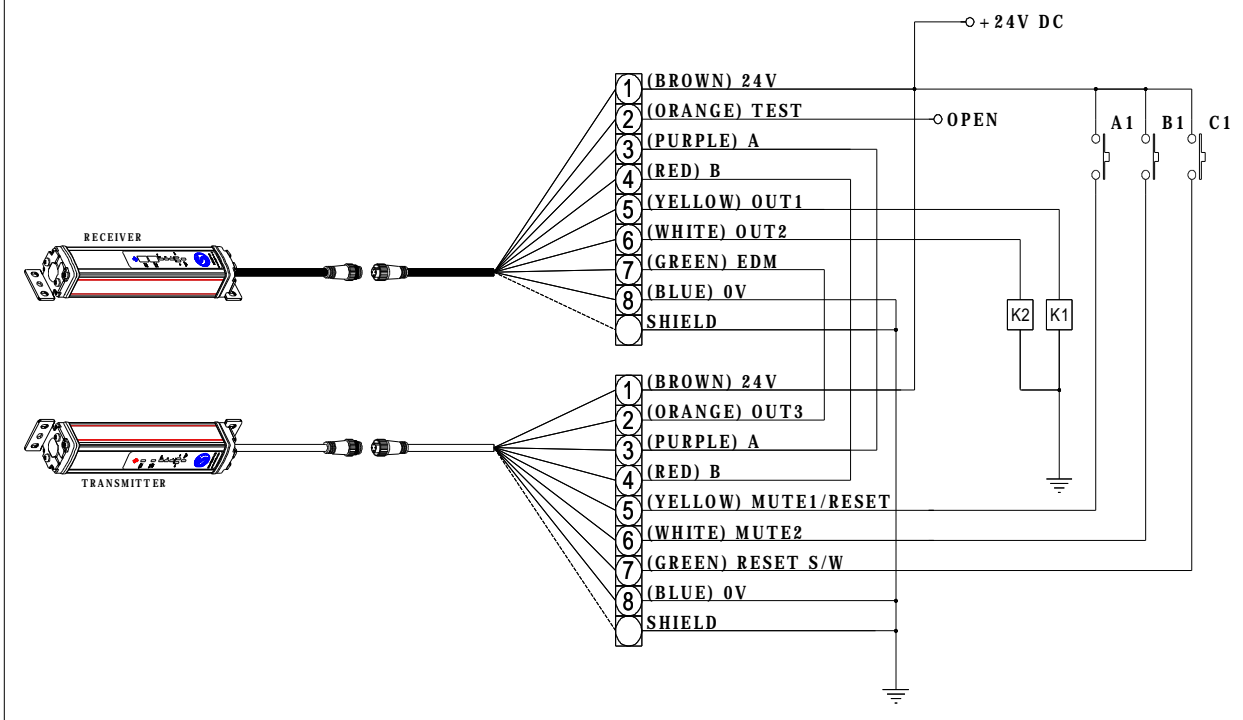

10- 1. Override start condition

1. Muting input of B1 is not activated within 3s after muting input of A1 comes in
2. When the two muting signals of A1 and B1 don't go off within 60s after activation of A1 and B1
3. When the reset(C1) input is turns from OFF to ON and/or the test input turns from ON to OFF

10- 2. Override end condition

1. When the state of override continues for 60s
2. When the input of reset turns ON to OFF

11. Installation Condition

Warning !

- Install a protective structure so that the hazardous part of a machine can only be reached by passing through the sensor's detection zone.
- Install the interlock reset switch in a location that provides a clear view of the entire hazardous zone and where it cannot be activated from within the hazardous zone.
- Make sure that the SK-S2□□P is securely mounted and its cables and connectors are properly connected.

12. Safety Distance

■ How to calculate the safety distance specified by International Standard
(European standard EN999)

If a person approaches the detection zone of the SK-S2□□P perpendicularly

$$S = K \times T + C \dots\dots\dots \text{Formula (1)}$$

S : Safety distance

K : Approach speed to the detection zone

T : Total response time of the machine and SK-S2□□P

C : Additional distance calculated by the detection capability of the SK-S2□□P

System that has detection capability of 40mm or less

$$K = 2,000\text{mm/s}, C = 8 \times (d-14\text{mm})$$

$$S = 2,000\text{mm/s} \times (T_m + T_s) + 8 \times (d-14\text{mm})$$

S : Safety distance (mm)

T_m : Machine's response time (s)

T_s : Response time of the SK-S2□□P from ON to OFF (s)

d : Detection capability of the SK-S2□□P (mm)

Calculation example

When T_m = 0.05s, T_s = 0.01s, and d = 32mm

$$\begin{aligned} S &= 2,000\text{mm/s} \times (0.05\text{s} + 0.01\text{s}) + 8 \times (32\text{mm} - 14\text{mm}) \\ &= 264\text{mm} \dots\dots\dots \text{Formula (2)} \end{aligned}$$

As a result of the calculation safety distance S = 264mm

Distance from Reflective Surfaces

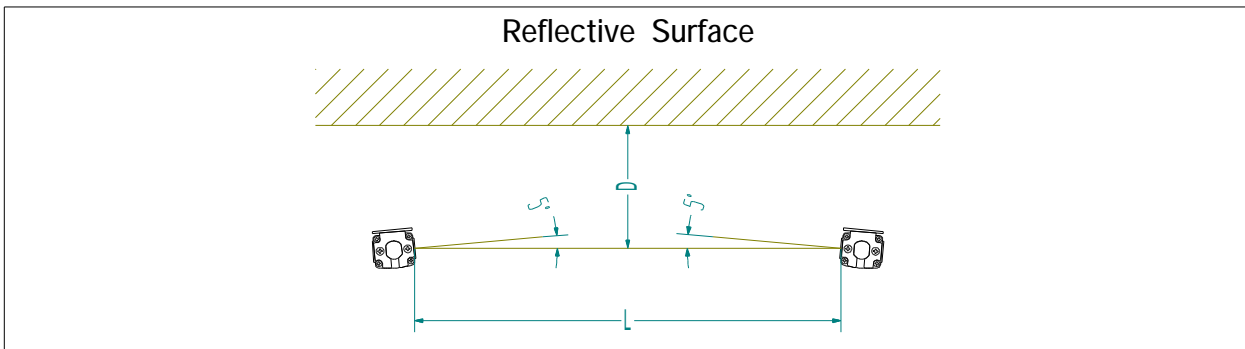
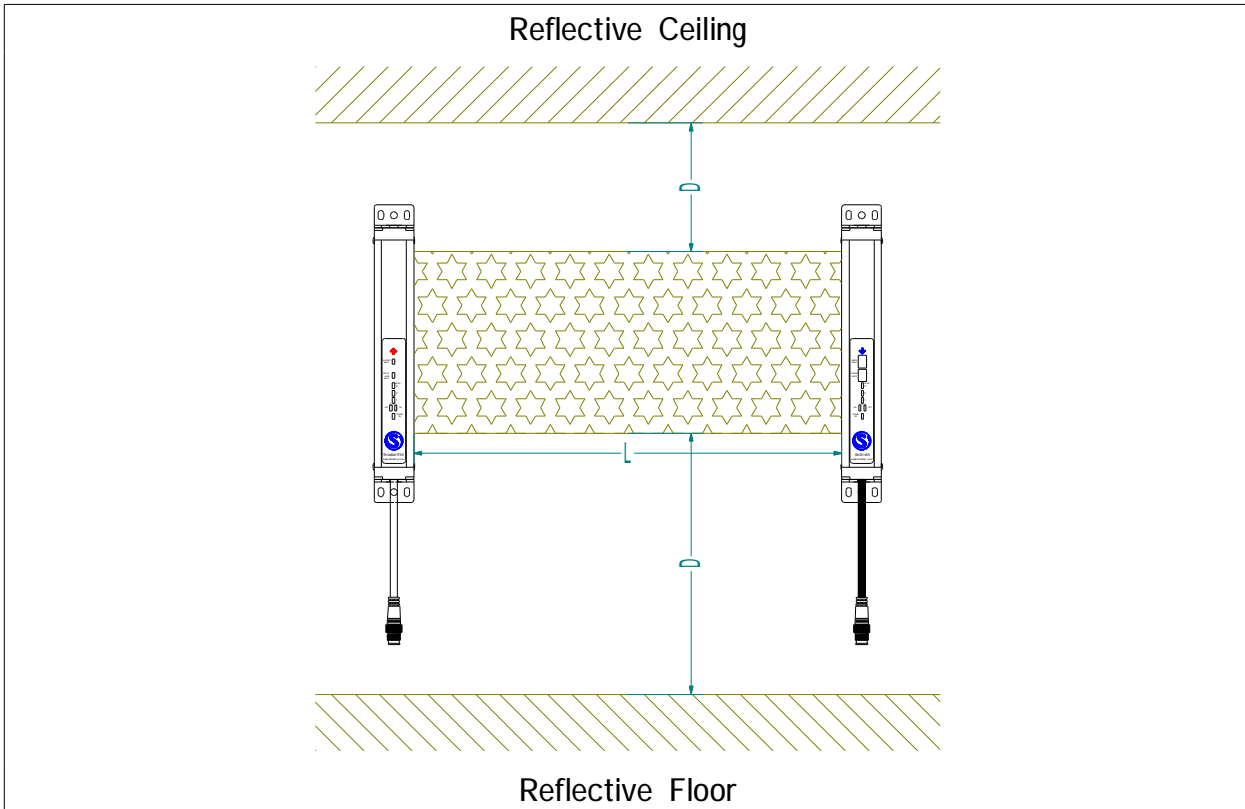

Distance between an emitter and a receiver (operating range L)	Allowable installation distance : D
For 0.2 to 3m	0.13m
For 3m or more	$L/2 \times \tan 5^\circ = L \times 0.044(m)$

13. Setting Example

■ Install a physical barrier between 2 sets

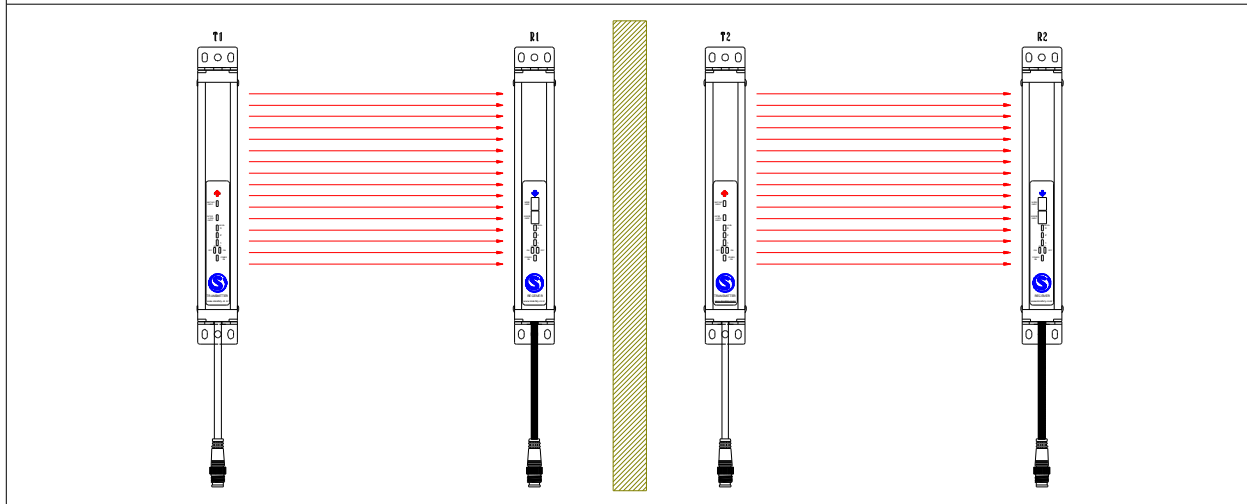

■ Alternate the direction of emission between 2 sets (alternation)

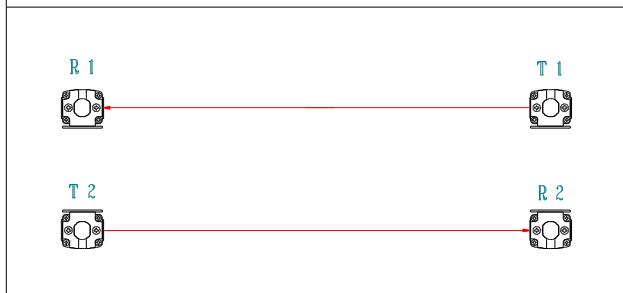

■ Keep sufficient distance so that mutual interference does not occur (aligned vertically)

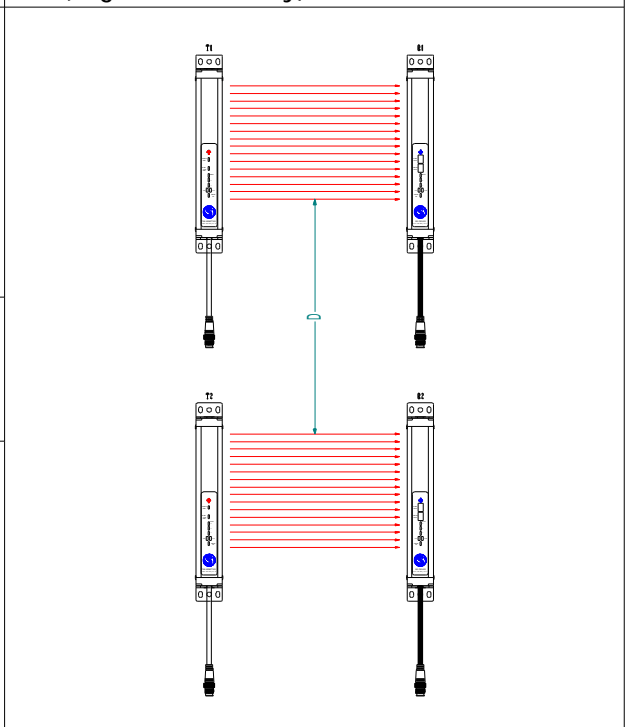

■ Keep sufficient distance so that mutual interference does not occur (aligned fore and after)

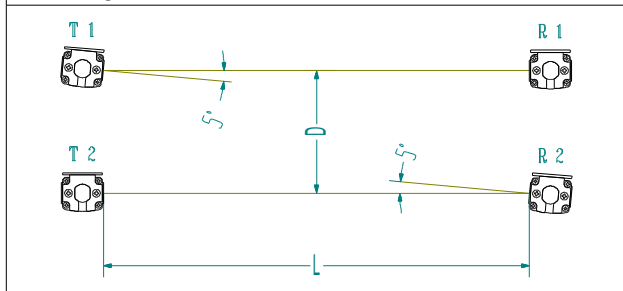

Distance between an emitter and a receiver (operating range L)	Allowable installation distance : D
For 0.2 to 3m	0.26m
For 3m or more	$L \times \tan 5^\circ = L \times 0.088(m)$

14. DIMENSION & DEVELOPMENT FIGURE

14- 1. DIMENSION

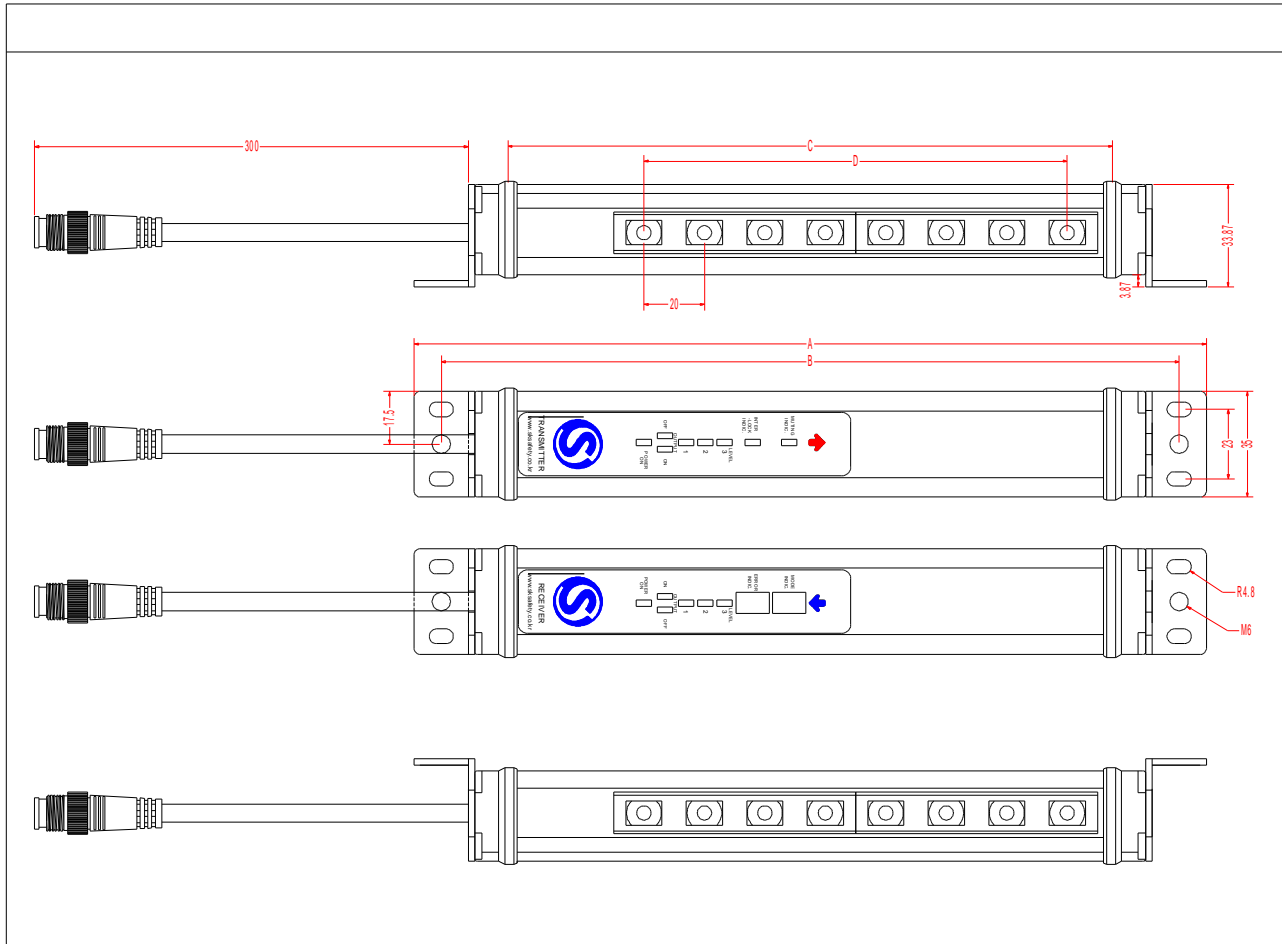

	MODEL	A(C+62)	B(C+44)	C	D(C- 50)
1	SK- S212P- □	332	314	270	220
2	SK- S216P- □	412	394	350	300
3	SK- S220P- □	492	474	430	380
4	SK- S224P- □	572	554	510	460
5	SK- S228P- □	652	634	590	540
6	SK- S232P- □	732	714	670	620
7	SK- S236P- □	812	794	750	700
8	SK- S240P- □	892	874	830	780
9	SK- S244P- □	972	954	910	860
10	SK- S248P- □	1052	1034	990	940
11	SK- S252P- □	1132	1114	1070	1020
12	SK- S256P- □	1212	1194	1150	1100
13	SK- S260P- □	1292	1274	1230	1180
14	SK- S264P- □	1372	1354	1310	1260

14- 2. TRANSMITTER DEVELOPMENT FIGURE

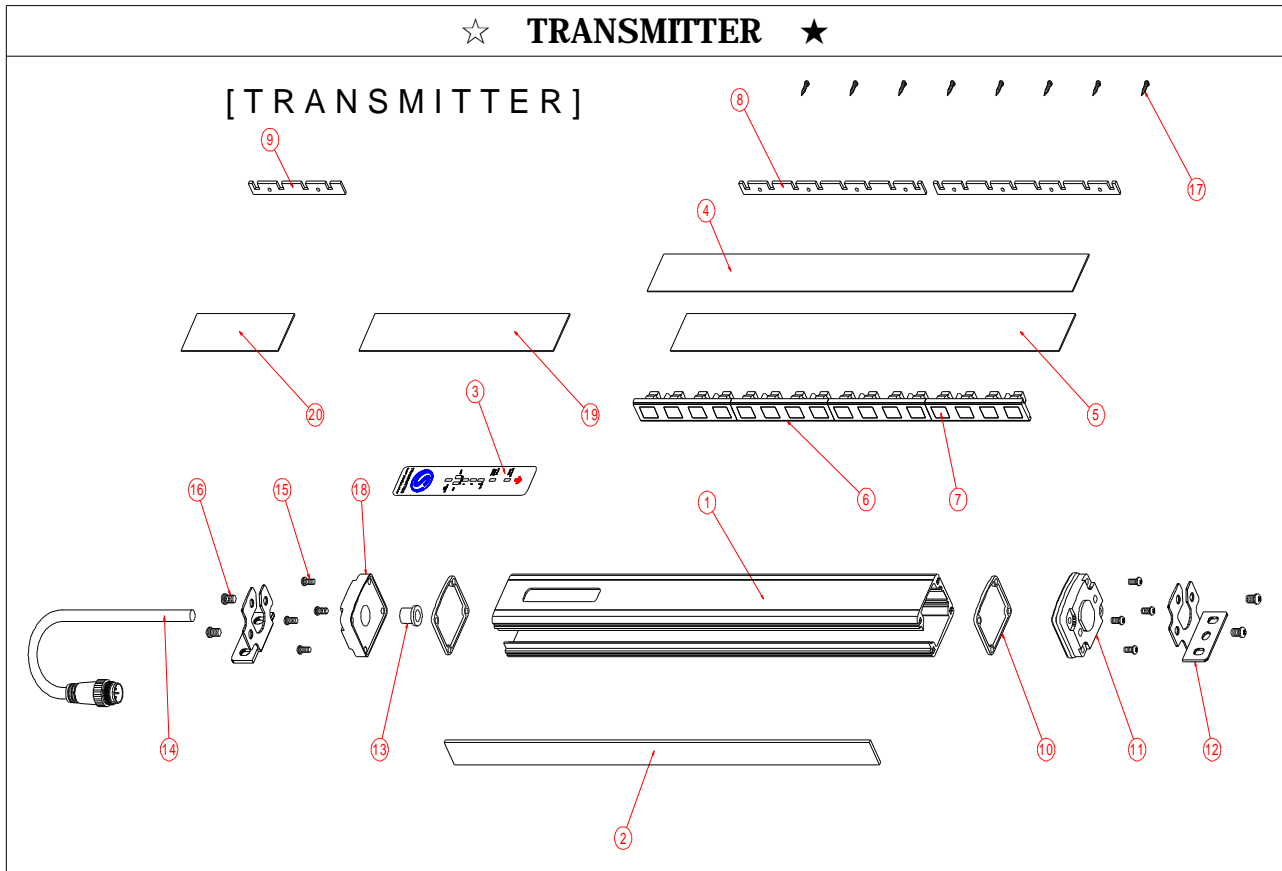

	PART	S212P	S216P	S220P	S224P	S228P	S232P	S236P	S240P	S244P	S248P	S252P	S256P	S260P	S264P		
		-T	-T	-T	-T	-T	-T	-T	-T	-T	-T	-T	-T	-T	-T		
1	Case	1	1	←	←	←	←	←	←	←	←	←	←	←	←		
2	Acrylic	1	1	←	←	←	←	←	←	←	←	←	←	←	←		
3	Sticker	1	1	←	←	←	←	←	←	←	←	←	←	←	←		
4	Main PCB	1	1	←	←	←	←	←	←	←	←	←	←	←	←		
5	Module PCB(16Port)	1	1	←	←	←	2	←	←	←	3	←	←	←	4		
6	Lens Block	3	4	5	6	7	8	9	10	11	12	13	14	15	16		
7	Lens	12	16	20	24	28	32	36	40	44	48	52	56	60	64		
8	Photo Support (8Port)	1	2	←	3	←	4	←	5	←	6	←	7	←	8		
9	Photo Support (4Port)	1	-	1	-	1	-	1	-	1	-	1	-	1	-		
10	Cap Rubber	2	2	←	←	←	←	←	←	←	←	←	←	←	←		
11	Cap B(Upper)	1	1	←	←	←	←	←	←	←	←	←	←	←	←		
12	Bracket	2	2	←	←	←	←	←	←	←	←	←	←	←	←		
13	Cable Rubber	1	1	←	←	←	←	←	←	←	←	←	←	←	←		
14	Cable	1	1	←	←	←	←	←	←	←	←	←	←	←	←		
15	Bolt(3×16)	8	8	←	←	←	←	←	←	←	←	←	←	←	←		
16	Bolt(4×8)	4	4	←	←	←	←	←	←	←	←	←	←	←	←		
17	Screw(2×10)	8	8	10	12	14	16	18	20	22	24	26	28	30	32		
18	Cap B(Lower)	1	1	←	←	←	←	←	←	←	←	←	←	←	←		
19	Module PCB(8Port)	-	-	-	1	1	-	-	1	1	-	-	1	1	-		
20	Module PCB(4Port)	-	-	1	-	1	-	1	-	1	-	1	-	1	-		

14- 3. RECEIVER DEVELOPMENT FIGURE

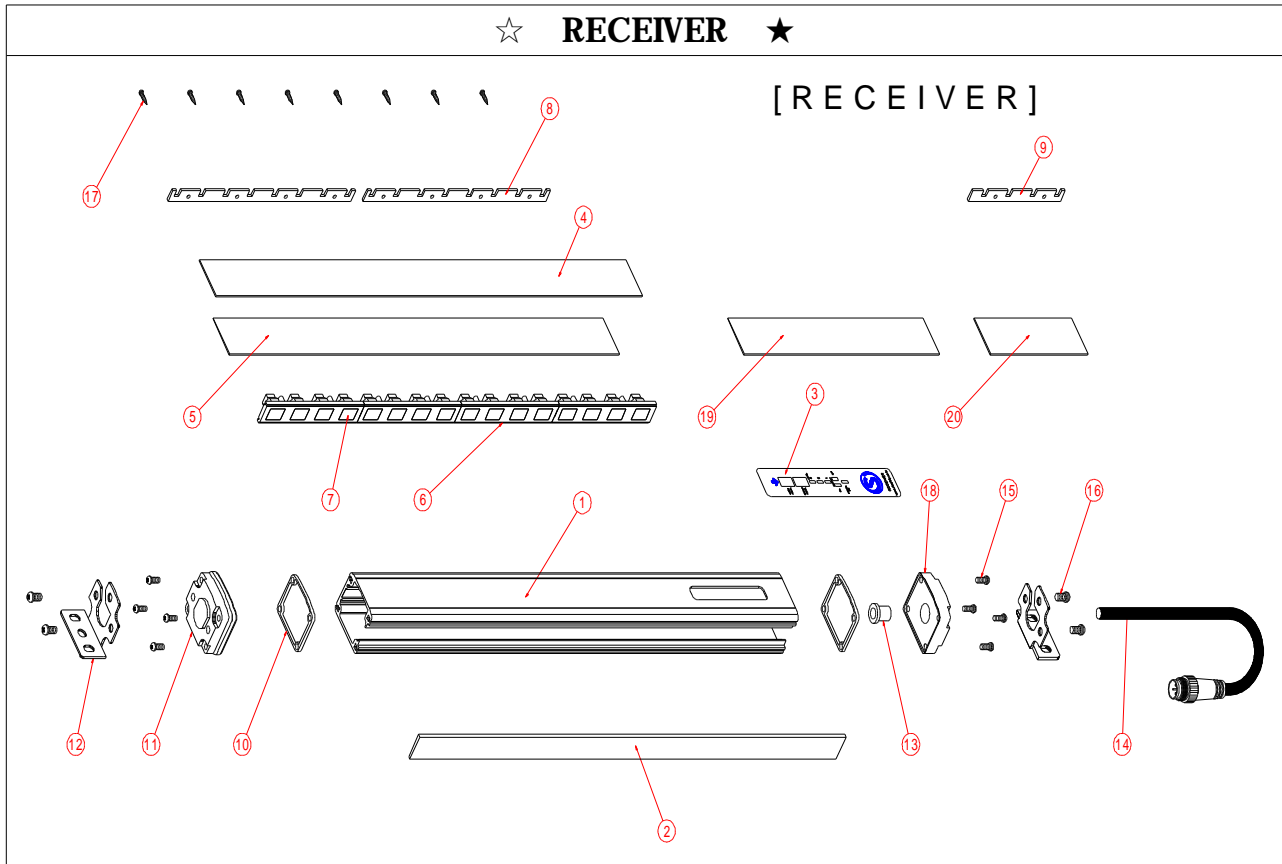

	PART	S212P	S216P	S220P	S224P	S228P	S232P	S236P	S240P	S244P	S248P	S252P	S256P	S260P	S264P		
		- R	- R	- R	- R	- R	- R	- R	- R	- R	- R	- R	- R	- R	- R		
1	Case	1	1	←	←	←	←	←	←	←	←	←	←	←	←		
2	Acrylic	1	1	←	←	←	←	←	←	←	←	←	←	←	←		
3	Sticker	1	1	←	←	←	←	←	←	←	←	←	←	←	←		
4	Main PCB	1	1	←	←	←	←	←	←	←	←	←	←	←	←		
5	Module PCB(16Port)	1	1	←	←	←	2	←	←	←	3	←	←	←	4		
6	Lens Block	3	4	5	6	7	8	9	10	11	12	13	14	15	16		
7	Lens	12	16	20	24	28	32	36	40	44	48	52	56	60	64		
8	Photo Support (8Port)	1	2	←	3	←	4	←	5	←	6	←	7	←	8		
9	Photo Support (4Port)	1	-	1	-	1	-	1	-	1	-	1	-	1	-		
10	Cap Rubber	2	2	←	←	←	←	←	←	←	←	←	←	←	←		
11	Cap B(Upper)	1	1	←	←	←	←	←	←	←	←	←	←	←	←		
12	Bracket	2	2	←	←	←	←	←	←	←	←	←	←	←	←		
13	Cable Rubber	1	1	←	←	←	←	←	←	←	←	←	←	←	←		
14	Cable	1	1	←	←	←	←	←	←	←	←	←	←	←	←		
15	Bolt(3×16)	8	8	←	←	←	←	←	←	←	←	←	←	←	←		
16	Bolt(4×8)	4	4	←	←	←	←	←	←	←	←	←	←	←	←		
17	Screw(2×10)	8	8	10	12	14	16	18	20	22	24	26	28	30	32		
18	Cap B(Lower)	1	1	←	←	←	←	←	←	←	←	←	←	←	←		
19	Module PCB(8Port)	-	-	-	1	1	-	-	1	1	-	-	1	1	-		
20	Module PCB(4Port)	-	-	1	-	1	-	1	-	1	-	1	-	1	-		

15. External Device Monitoring Function (EDM)

15- 1. Wiring Diagram

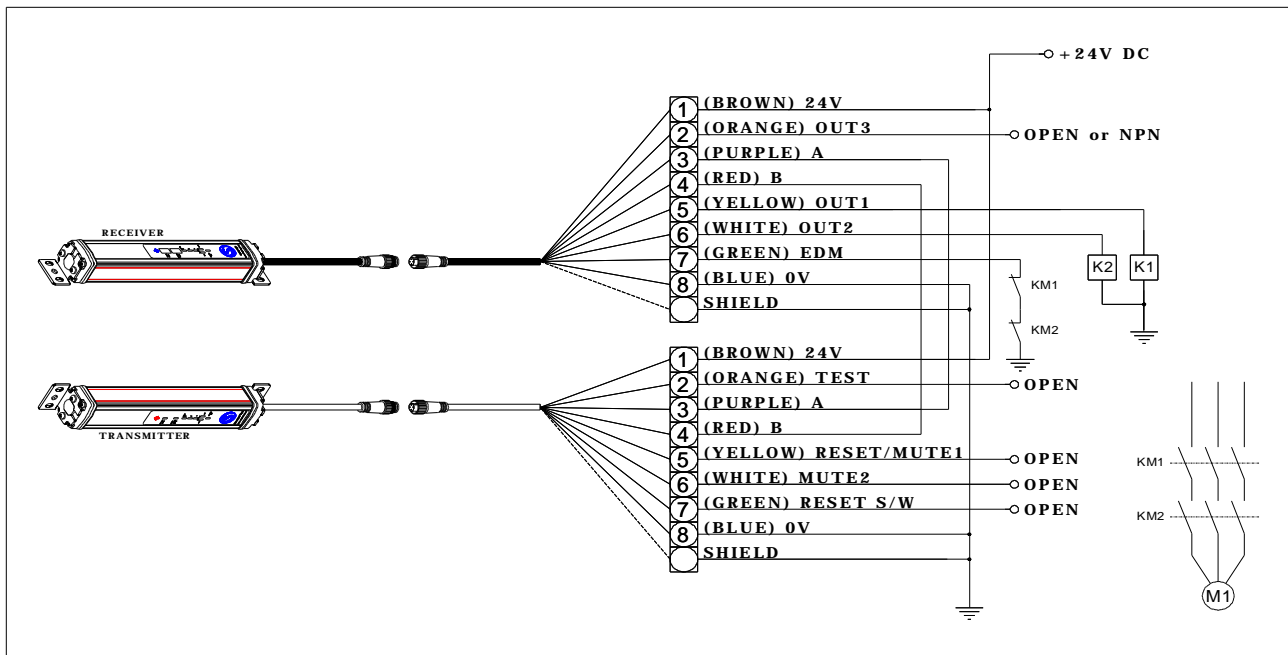

EN ISO 13849-1 Safety Class 4 Wiring

■ Definition of External Device Monitoring

This function detects malfunctions, in external relays (or contactors) that control the hazardous zone of a machine.

This function constantly monitors that a specified voltage is applied to the receiver's external device monitoring input line, and enters lockout state when an error occurs.

To utilize this function properly, use safety relays and contactors that have forcibly guided or mechanically linked contact structure.

■ Wiring

When external device monitoring is not being used, apply auxiliary output 3 to the external device monitoring.

Perform wiring so that 0V is applied to the external device monitoring line of the receiver via the external relay's normally closed (N.C.) contact "B"

16. Usage of test rod

16- 1. Dimension

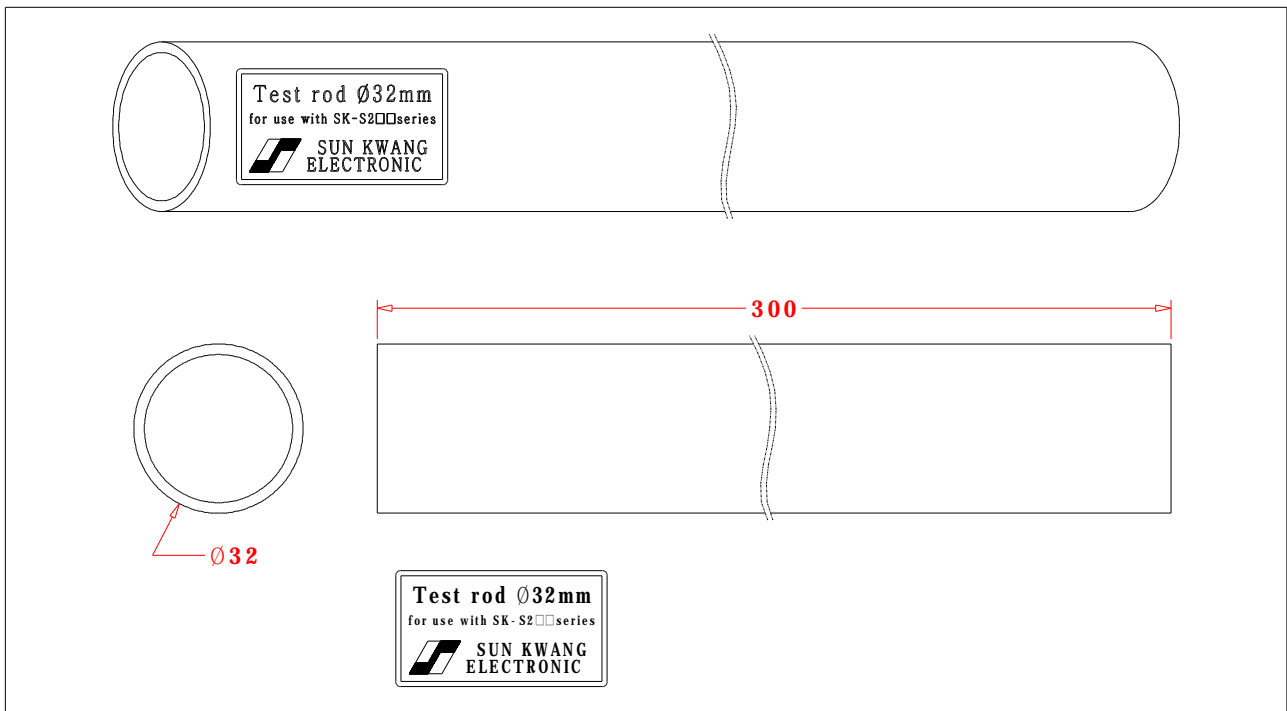

16- 2. Correct Use

How to check and interrupt light curtain of SK-S2□□P by test rod after installation.

- ① Check that the barrier operates correctly
- ② Move the testing tool within the whole protection area as below picture.
- ③ The safety outputs of light curtain should stay on 'OFF' during the test.

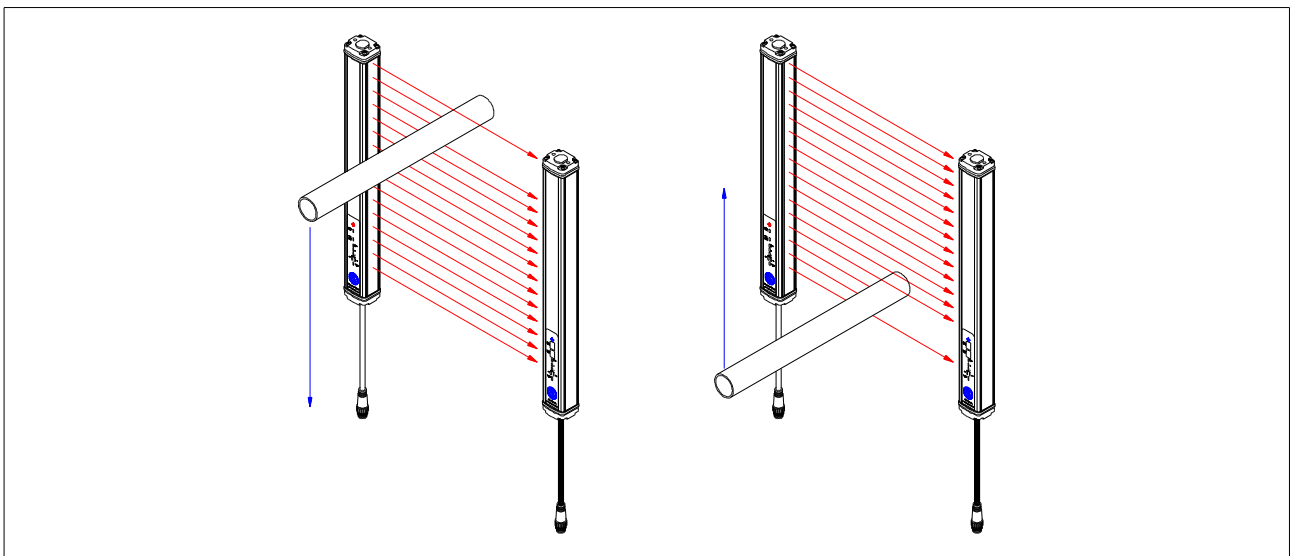

- ④ Repeat the above procedure 2~3 times.

17. Routine Checks

The follow is a list of recommended checks that should be done regularly:

- ① Check damage and impurity on Acryl of SK- S2□□P
- ② Check the mounted brackets and connected cables.
- ③ Check that safety outputs turn off by blocking the light curtain.

18. Length of cable

Contain power cable in total extended length of cable.

The maximum cable length of SK- S2□□P 30M. [AWG #26 8C]

In case that the total length of cable exceeds the limit, the barrier won't properly work.

19. Precautions for correct use

- Injury or death may possibly occur due to incorrect use.
- Serious injury may possibly occur due to malfunction of safety output by connecting loads than safety outputs' load.
- This product is designed for safety category 4 according to EN ISO 13849-1.
- Serious injury may occur due to the loss of safety function.
- Please wire properly so that safety outputs do not short-circuit with the power supply of load power supply

Handle with Care

- Do not drop SK- S2□□P to the ground of expose to excessive vibration of mechanical shocks.
- Do not store and install in such conditions stated below.
 1. In direct sunlight
 2. In corrosive of combustible gases.
 3. Under splashing of water, oil, chemicals.
 4. With vibration or mechanical shocks out of the rated values.
 5. At ambient temperatures out of the range of - 10to 55°C.

20. Legislation and Standards

- 1. Application of a SK-S2□□P alone cannot receive type approval by Industry Safety Health Law of Korea**
- 2. The SK-S2□□P electro-sensitive equipment(ESPE) in accordance with European Union (EU) Machinery Directive Index Annex IV ,B, Safety Components, Item 1.**
- 3. SK-S2□□P complies with the following Legislation and standards**

(1) EC Regulations

**Machinery Directive 2006/42/EC
Low Voltage Directive 2006/95/EC
EMC Directive 2004/108/EC**

(2) European Standards

**EN61496- 1:2013 (type 4 ESPE)
EN61496- 2:2013 (type 4 AOPD)
EN 13849- 1:2008
EN 12100:2010
EN 62061:2005+ A1:2012
EN60204- 1:2006+ A1:2009**

(3) International Standards

**IEC61496- 1 (type 4 ESPE),
IEC61496- 2 (type 4 AOPD),**

(4) KS Standards

**KS C IEC 61496- 1(type 4 ESPE),
KS C IEC 61496- 2(type 4 AOPD)**