

WATER PROOF SWITCHES

DIMENSIONS

Unless otherwise specified, a tolerance of $\pm 0.4\text{mm}$ applies to all dimensions.

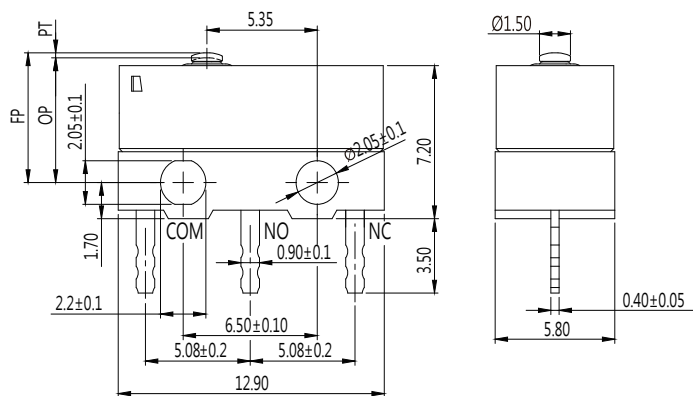

DFW SERIES

SPECIFICATIONS

Contact Resistance (initial)

Max. 100m Ω

(Measured by ohm meter-Open Voltage<1VDC,Driver current-100mA)

Insulation Resistance (at 500VDC/minute)

Min. 100M Ω

Dielectric Strength

Min. 500VAC(50-60HZ)/minute between Live parts.

Min. 1500VAC(50-60HZ)/minute between Live parts and dead metal parts

Operating Temperature Range

-40°C to 85°C (with no icing)

Vibration

10~55Hz, displacement 0.75 mm (p-p)

Electrical Service Life

Min. 10,000 operations

Electrical Operating Frequency

10~30 operations per minute

Mechanical Service Life

Min. 1,000,000 operations

Mechanical Operating Frequency

120 operations per minute

Operating application of the switch

Set the switch pushing distance from 60% to 90% of the specified OT value

Degree of Protection

IP67 (excluding the terminals on terminal models)

APPLICATIONS

Automotive (Operation system, Engine area Interior)

Air conditioner, communication, Electric tooth brush, Toy

CERTIFICATE INFORMATION

Model Name	UL, cUL	ENEC
DFW-P1	0.1RA 125/250VAC μ T85 1E4	0.1A 125/250VAC μ T85 1E4
DFW-G1	3RA 24VDC μ T85 1E4	3A 24VDC μ T85 1E4
DFW-03	3RA 125/250VAC μ T85 1E4	3A 125/250VAC μ T85 1E4
DFW-G3	3RA 24VDC μ T85 1E4	3A 24VDC μ T85 1E4
DFW-05	5RA 125/250VAC μ T85 1E4 3RA 24VDC μ T85 1E4	5A 125/250VAC μ T85 1E4 3A 24VDC μ T85 1E4

CONTACT CONFIGURATION

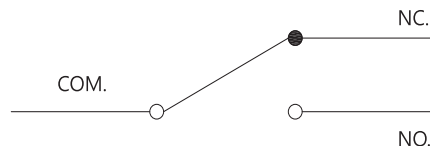

MOUNTING HOLES FOR PCB TERMINAL

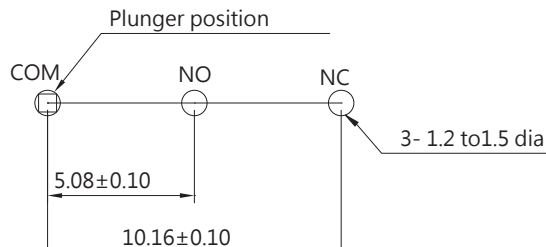

THE SELECTION OF RATING & FORCE

Model	Rating	L	S
DFW	P1	*	*
	G1		
	03	*	*
	G3		
	05	*	*

NOTE : The Symbol " * " to represent the result is accepted

TERMINAL TYPES

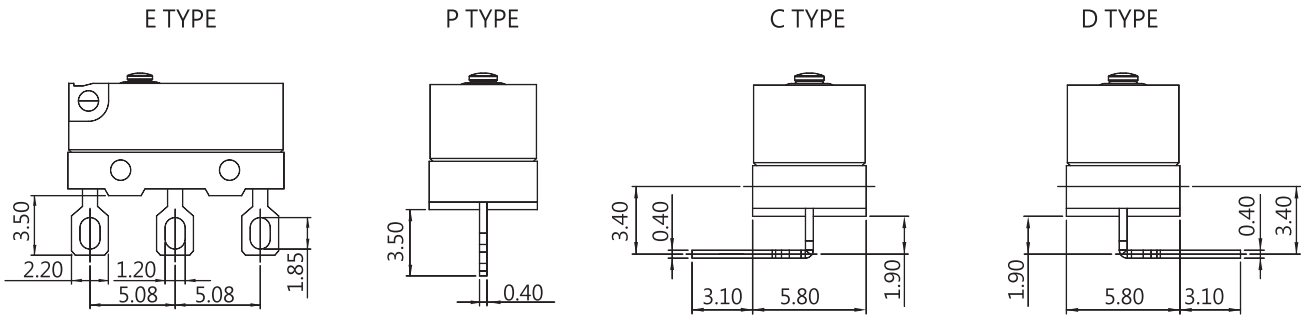

COVER TYPES

A type

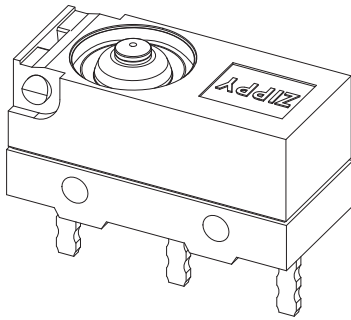

A type – Screw holes Ø1.2 mm

E type

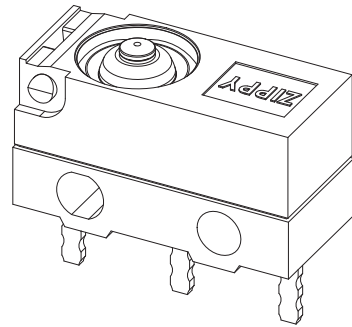

E type – Screw holes Ø2.05 mm

ORDERING INFORMATION

D F W	0 5	S	B 0 1	P	0	A	Z
SERIES PREFIX	CODE RATING CURRENT	CODE OPERATING FORCE	CODE ACTUATOR TYPE	CODE TERMINAL TYPE	CODE CIRCUIT ARRANGEMENT	CODE COVER&CASE TYPE	ROHS CODE
	P1 0.1A G1 125/250VAC	S STANDARD L LIGHT	A00 A01 A02	C D E P	0 S.P.D.T 1 S.P.S.T NO 2 S.P.S.T NC	A E	
	03 3A G3 125/250VAC		B00 B01 B02				
	05 5A 125/250VAC						

OPERATING CHARACTERISTICS (Internal snap-fit lever)

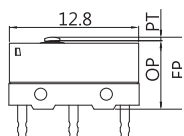
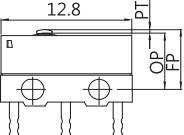
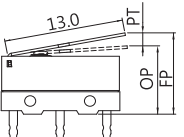
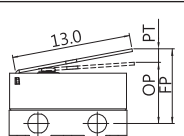
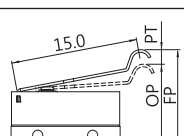
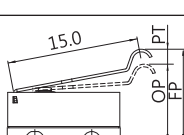
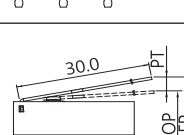
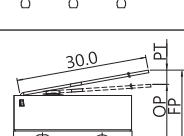
SWITCH TYPE	PART SUFFIX	OF Max. (gf)		OP (mm)	PT Max. (mm)	OT Min. (mm)	MD Max. (mm)	FP Max. (mm)	RF Min. (gf)
		L	S						
DFW- □□□ -A00 □ -Z		L	100	7.0 ± 0.2	0.5	0.2	0.12	7.5	21
		S	170						35
		L	100	5.9 ± 0.2	0.5	0.2	0.12	6.4	21
		S	170						35
DFW- □□□ -A01 □ -Z		L	32	8.2 ± 0.8	3.4	0.6	0.8	10.1	5
		S	56						8
		L	32	7.1 ± 0.8	3.4	0.6	0.8	9.0	5
		S	56						8
DFW- □□□ -A02 □ -Z		L	28	10.2 ± 0.8	3.5	0.7	0.92	14.2	5
		S	48						7
		L	28	9.1 ± 0.8	3.5	0.7	0.92	13.1	5
		S	48						7
DFW- □□□ -A09 □ -Z		L	22	9.5 ± 1.7	6.9	0.55	1.9	16.8	1
		S	24						3
		L	22	8.4 ± 1.7	6.9	0.55	1.9	15.7	1
		S	24						3

OPERATING CHARACTERISTICS (External snap-fit lever)

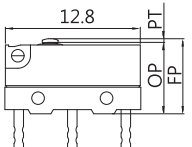
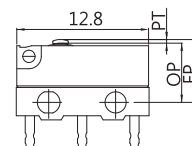
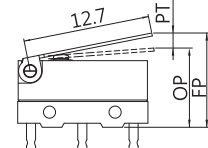
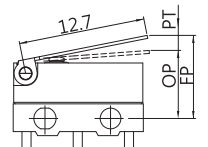
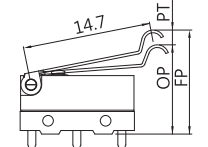
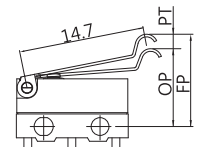
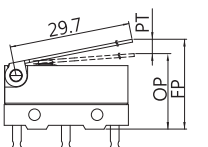
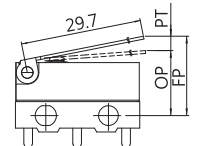
SWITCH TYPE	PART SUFFIX	OF Max. (gf)		OP (mm)	PT Max. (mm)	OT Min. (mm)	MD Max. (mm)	FP Max. (mm)	RF Min. (gf)
		L	S						
DFW- □□□ -B00 □ -Z		L	100	7.0 ± 0.2	0.5	0.2	0.12	7.5	21
		S	170						35
		L	100	5.9 ± 0.2	0.5	0.2	0.12	6.4	21
		S	170						35
DFW- □□□ -B01 □ -Z		L	32	8.2 ± 0.8	3.4	0.6	0.8	10.1	5
		S	56						8
		L	32	7.1 ± 0.8	3.4	0.6	0.8	9.0	5
		S	56						8
DFW- □□□ -B02 □ -Z		L	28	10.2 ± 0.8	3.5	0.7	0.92	14.2	5
		S	48						7
		L	28	9.1 ± 0.8	3.5	0.7	0.92	13.1	5
		S	48						7
DFW- □□□ -B09 □ -Z		L	22	9.5 ± 1.7	6.9	0.55	1.9	16.8	1
		S	24						3
		L	22	8.4 ± 1.7	6.9	0.55	1.9	15.7	1
		S	24						3

CAUTIONS:

注意事項

1. To secure the switch, please use an M2 small screw on a flat surface and tighten with plane washers or spring washers to securely mount the Switch, using a maximum torque of 0.1 N•m.
若使用定位孔型式上蓋，請使用M2小型螺絲固定在平面上，並使用平墊圈或者彈性墊圈以便安全的鎖固開關，鎖固扭力請勿超過0.1N•m。
2. Do not handle the switch in a way that may cause damage to the sealed rubber & switch sealing.
使用開關時，請勿損壞開關防水矽膠罩及開關防水膠。
3. To ensure the best performance of the switch, when handling/installing the switch, please do not apply uneven pressure to the direction indicated by the arrow in Figure 1. Any uneven pressure or pressure direction other than the operating direction might be harmful or damage the switch performance.
為確保開關正常運作，安裝及取用開關時，請勿直接施加壓力在圖-1中箭頭所指示的方向。如圖所示，任何不對稱的壓力或作動方向以外的壓力都不適用在開關按柄上。
4. Do not exceed the end position (EP) and over travel (OT). This could cause operation failure.
圖示設計按壓位置，請勿超過開關下死點及超出行程，以避免開關失效。
5. Avoid applying any grease/oil and chemicals on the switch rubber.
請避免沾附任何油脂或者化學物質在開關的矽膠防水罩上。

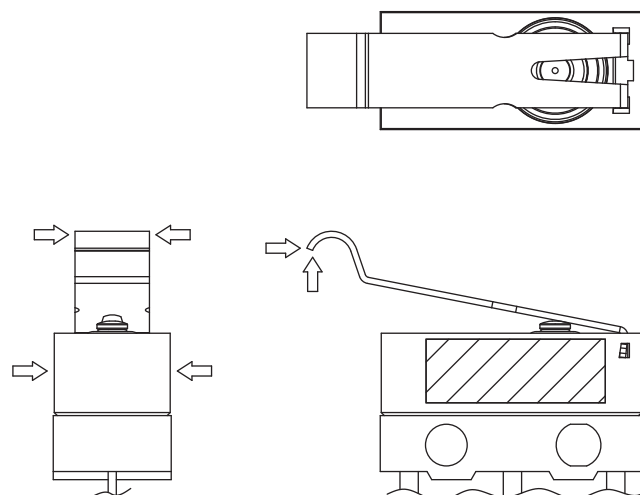

Figure-1 (圖-1)