

压缩泵 & 真空泵 / Compressor and Vacuum Pump

型式 DP0105-X1

面向中国
RoHS 机种
12V

有刷马达
/ Brush DC Motor
(12 V DC)

兼用 / Dual Type

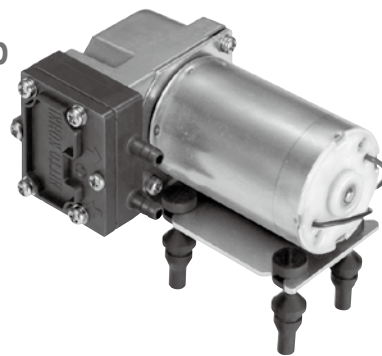

空气量和消耗功率 / Airflow & Electric Current

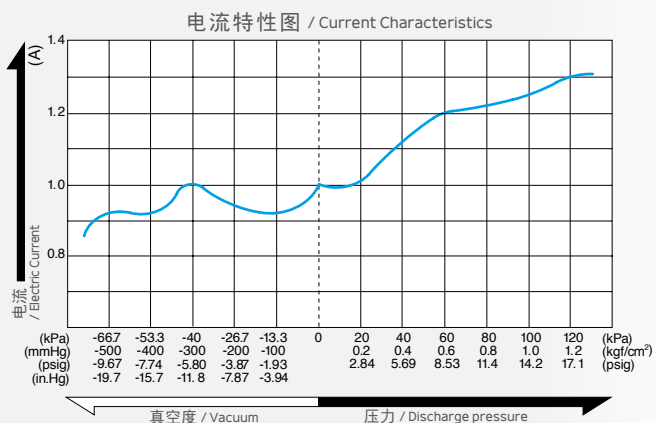
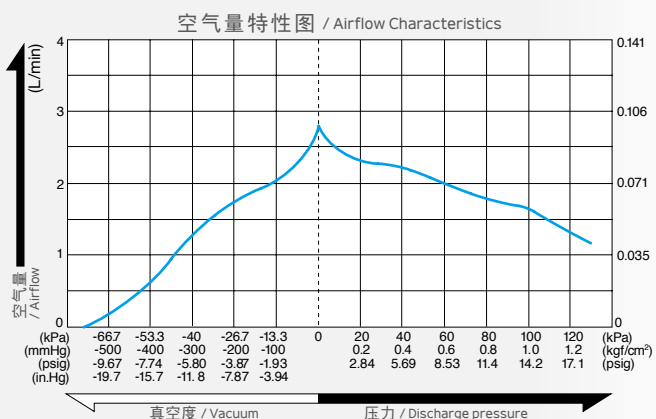

※ 特性图只是参考值，并不是保证值。
/ The characteristic charts are for reference only and are not guaranteed.

规格 / Specifications

达到真空度 / Attainable Vacuum	-66.7 kPa (-500 mmHg) -667 mbar -19.7 in.Hg
吐出空气量 / Free Air Displacement	2.8 L/min 0.099 cfm
额定电压 / Rated Voltage	12 V DC
最高压力 / Maximum Pressure	250 kPa (2.5 kgf/cm ²) 2.5 bar 35.6 psig
最大电流 / Maximum Current	1.9 A
额定时间 / Duty Cycle	30 minutes
使用压力范围 / Working Pressure Range	-66.7 ~ 100 kPa (-500 mmHg ~ 1 kgf/cm ²) -667 mbar ~ 1 bar -19.7 in.Hg ~ 14.2 psig
耐用时间 (MTTF) / Rated Performance (MTTF)	2,000 小时 / hours
吸入口尺寸 / Inlet	φ5 mm (外径) 直管接头 / 5 mm O.D. straight barb
吐出口尺寸 / Outlet	φ5 mm (外径) 直管接头 / 5 mm O.D. straight barb
线圈绝缘等级 / Coil Insulation Class	相当于 E 类 E or its equivalent
安装尺寸 / Mounting Dimensions	42 (L) x 24.5 (W) mm 1-21/32" (L) x 1-31/32" (W)
本体重量 / Weight	0.36 kg 0.79 Lbs
导线长度 / Leadwire Length	360 mm 14-11/64"

用途例 / Application Examples

自动售货机 / Vending Machines

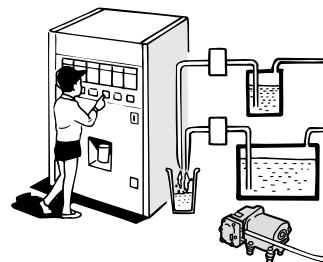

外形及安装尺寸图 / Dimensional Outline Drawing (单位 / Unit : mm)

