

Report Number: QIP-ASI2241770

Audit Date : 15 Nov.,2022

This report is issued by Focus Technology Co., Ltd. (Made-in-China.com) and the supervising inspectorate (SGS-CSTC Standards Technical Services Co., Ltd.) to confirm that:

Company Name : Aoli Pack Products (Kunshan) Co., LTD
奥立包装制品(昆山)有限公司

Showroom : <https://slipsheet.en.made-in-china.com>

Address : No. 755, Datong Road, Penglang Town, Kunshan Development Zone, Suzhou, Jiangsu, China

Product : Slip Sheet, Plastic Slip Sheet, Paper Slip Sheet, Anti Slip Paper, Dunnage Bag

has been on site audited for the Following Scope of Activity

1. General Information
2. Foreign Trade Capacity
3. Product Research & Development Capacity
4. Management System and Product Certification
5. Production Capacity & Quality Control
6. Working Environment
7. Energy Saving and Emission Reduction
8. Photos



General Comments:



Sign for and on behalf of
SGS-CSTC Standards Technical Services Co., Ltd.

Unless otherwise agreed in writing, this document is issued by the Company under its General Conditions of Service accessible at <http://www.sgs.com/en/Terms-and-Conditions.aspx> Attention is drawn to the limitation of liability, indemnification and jurisdiction issues defined therein. Any holder of this document is advised that information contained hereon is solely limited to visual examination of the safely and readily accessible portions of the consignment and reflects the Company's findings at the time of its intervention only and within the limits of Client's instructions, if any. The Company's sole responsibility is to its Client and this document does not exonerate parties to a transaction from exercising all their rights and obligations under the transaction documents. Any unauthorized alteration, forgery or falsification of the content or appearance of this document is unlawful and offenders may be prosecuted to the fullest extent of the law.

Page No.: 1 of 16



SGS-CSTC Standards Technical Services Co., Ltd.
Consumer and Retail Service

5/F, B-4 Building, Zijin (Baixia) Technology Incubation Special Park, No.1 Guanghua Road, Nanjing, China 210014 t (86-25) 87128385 f (86-25) 83407773 www.sgsgroup.com.cn
中国·南京·秦淮区光华路1号紫金白下创业特别社区4号楼B幢5楼 邮编: 210014 t (86-25) 87128385 f (86-25) 83407773 e as.cn@sgs.com

SUPPLIER ASSESSMENT REPORT

Audited Company	Aoli Pack Products (Kunshan) Co., LTD		
Audited Site:	No. 755, Datong Road, Penglang Town, Kunshan Development Zone, Suzhou, Jiangsu, China		
Consigner of Assessment	Made-in-China.com		
Audit Type	<input checked="" type="checkbox"/> Initial Audit <input type="checkbox"/> Re-audit		
Audit Date	15 Nov.,2022	Verify Report	https://auditedsupplier.sgs.com.cn/
Auditor	Easy Ding	Reviewed by	Ellie Jin



CONTENTS

- Part A: General Information**
 - Section 1: Company Overview
 - Section 2: Human Resources
- Part B: Foreign Trade Capacity**
 - Section 1: Export Overall Situation
 - Section 2: Export Business Capacity
 - Section 3: Supplier Management
 - Section 4: After-sales Service Capacity
- Part C: Product Research & Development Capacity**
 - Section 1: Product Research & Development Capacity
- Part D: Management System and Product Certification**
 - Section 1: Management System(s) and Product Certification
- Part E: Production Capacity & Quality Control**
 - Section 1: Production Capacity Section
 - Section 2: Production Process Control
- Part F: Financial Position**
 - Section 1: Financial Data
 - Section 2: Key Performance Indications
 - Section 3: Banking
 - Section 4: Product Insurance
- Part G: Working Environment**
 - Section 1: Working Environment
- Part H: Energy Saving and Emission Reduction**
 - Section 1: Environmental Management
 - Section 2: Water, Gas and Noise Control
- Part I: Industry Information**
 - Section 1: Industry Information
- Part J: Photos**
 - Section 1: Photos of Documents
 - Section 2: Photos of Company

Unless otherwise agreed in writing, this document is issued by the Company under its General Conditions of Service accessible at <http://www.sgs.com/en/Terms-and-Conditions.aspx>. Attention is drawn to the limitation of liability, indemnification and jurisdiction issues defined therein. Any holder of this document is advised that information contained hereon is solely limited to visual examination of the safely and readily accessible portions of the consignment and reflects the Company's findings at the time of its intervention only and within the limits of Client's instructions, if any. The Company's sole responsibility is to its Client and this document does not exonerate parties to a transaction from exercising all their rights and obligations under the transaction documents. Any unauthorized alteration, forgery or falsification of the content or appearance of this document is unlawful and offenders may be prosecuted to the fullest extent of the law.



Part A: General Information

Section 1: Company Overview

1.1 Legal Validity			
Does the company have a valid business license?	<input checked="" type="checkbox"/> Yes <input type="checkbox"/> No <input type="checkbox"/> Others	Registration Number	91320583MA1T5PEBXY
Year of established	24 Oct.,2017	Valid Date	Long Valid
Registered address	No. 755, Datong Road, Penglang Town, Kunshan Development Zone, Suzhou, Jiangsu, China		
Actual address	No. 755, Datong Road, Penglang Town, Kunshan Development Zone, Suzhou, Jiangsu, China		
Does the company in abnormal operation status list of industrial and commercial bureau?	No		
Registered capital	5,000,000 RMB		
Name of legal representative	Mr. Weixin Zhou		
Business scope	Packaging materials, paper products, plastic products, warehousing logistics equipment, hardware tools production, research and development, sales; Sales of mechanical and electrical equipment, forklift accessories, packing equipment and packing belts, labor protection products, shock-proof equipment, plates, desiccant, metal materials, plastic raw materials and products; Import and export of goods and technologies. (For projects subject to approval according to law, business activities can only be carried out after approval by relevant departments)		
1.2 Basic Information			
Contact person	Ms. Gao		
Phone number	0086-15250182905	Fax number	0086-512-50159186
URL/Web address	https://www.slipsheet.com/		
Company type	<input checked="" type="checkbox"/> Manufacturer <input type="checkbox"/> Trading Company <input type="checkbox"/> Combined <input type="checkbox"/> Group Corporation		
Type of ownership	<input checked="" type="checkbox"/> Limited Company <input type="checkbox"/> Public Company <input type="checkbox"/> Foreign joint venture <input type="checkbox"/> State-Owned <input type="checkbox"/> Private Owner <input type="checkbox"/> Wholly foreign-owned enterprises		
Associated company	Nil		
Products manufactured / sold scope	Slip Sheet, Plastic Slip Sheet, Paper Slip Sheet, Anti Slip Paper, Dunnage Bag		
1.3 Company Building Information			
According to: <input type="checkbox"/> Land certificate <input type="checkbox"/> Real estate certificate <input checked="" type="checkbox"/> Lease agreement <input type="checkbox"/> Observation Estimated on site			
The company area 2,077 square meters The land occupies / square meters. (Confidential) The offices occupy 300 square meters. The workshops occupy 1,777 square meters.			



Unless otherwise agreed in writing, this document is issued by the Company under its General Conditions of Service accessible at <http://www.sgs.com/en/Terms-and-Conditions.aspx>. Attention is drawn to the limitation of liability, indemnification and jurisdiction issues defined therein. Any holder of this document is advised that information contained hereon is solely limited to visual examination of the safely and readily accessible portions of the consignment and reflects the Company's findings at the time of its intervention only and within the limits of Client's instructions, if any. The Company's sole responsibility is to its Client and this document does not exonerate parties to a transaction from exercising all their rights and obligations under the transaction documents. Any unauthorized alteration, forgery or falsification of the content or appearance of this document is unlawful and offenders may be prosecuted to the fullest extent of the law.

Page No.: 3 of 16

Section 2: Human Resources

2.1 Company Chart

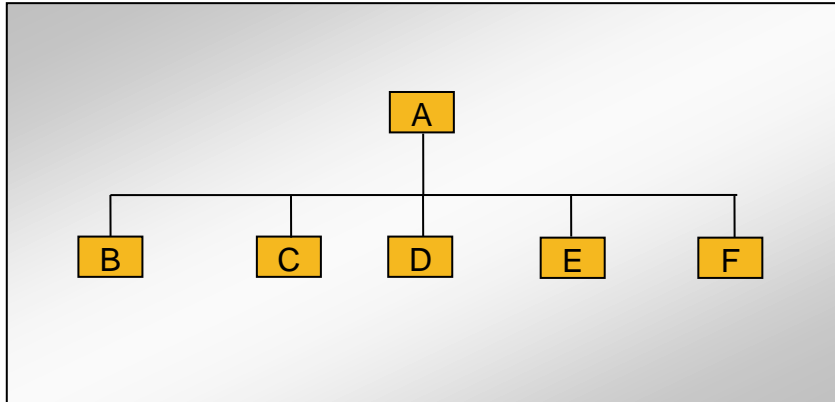

2.2 Explanation of Code and Employee Details

Code	Department	Number of employees
A	GM	1
B	Admin. Dept.	1
C	Financial Dept.	1
D	Sales Dept.	1
E	Technical Dept.	2
F	Production Dept.	9
Number in total:		15

2.3 Key Staff

Title	Full name	Education	Working experience for this trade / total experience
Sales Manager	Ms. Gao	Graduate	10 / 10 Years

Remark: Above information of key staff was based on interview with company representative.



Unless otherwise agreed in writing, this document is issued by the Company under its General Conditions of Service accessible at <http://www.sgs.com/en/Terms-and-Conditions.aspx>. Attention is drawn to the limitation of liability, indemnification and jurisdiction issues defined therein. Any holder of this document is advised that information contained hereon is solely limited to visual examination of the safely and readily accessible portions of the consignment and reflects the Company's findings at the time of its intervention only and within the limits of Client's instructions, if any. The Company's sole responsibility is to its Client and this document does not exonerate parties to a transaction from exercising all their rights and obligations under the transaction documents. Any unauthorized alteration, forgery or falsification of the content or appearance of this document is unlawful and offenders may be prosecuted to the fullest extent of the law.

Part B: Foreign Trade Capacity

Section 1: Export Overall Situation

1.1 Export Overall Situation	
Does the company have a valid Import and Export license?	<input checked="" type="checkbox"/> Yes <input type="checkbox"/> No
The import and export enterprise code.	91320583MA1T5PEBXY
The number of foreign trading staff with relevant trading experience.	<input type="checkbox"/> within 1 year staff <input type="checkbox"/> 1-5 years staff <input type="checkbox"/> 6-10 years staff <input checked="" type="checkbox"/> over 10 years 1 staff Total 1 staff
The language freely used by foreign trade staff	<input checked="" type="checkbox"/> English <input type="checkbox"/> others:
Annual revenue of previous year	Confidential
Annual export revenue of previous year	Confidential
Estimated export revenue for this year.	Confidential
Overseas agent / branch	<input type="checkbox"/> Yes <input checked="" type="checkbox"/> No
Nearest port	Shanghai Port
Acceptable quotation terms	<input checked="" type="checkbox"/> FOB <input checked="" type="checkbox"/> CIF <input checked="" type="checkbox"/> CFR
Acceptable payment terms	<input checked="" type="checkbox"/> LC <input checked="" type="checkbox"/> T/T <input checked="" type="checkbox"/> D/P <input checked="" type="checkbox"/> PayPal <input checked="" type="checkbox"/> Western Union <input checked="" type="checkbox"/> Small-amount payment
Average lead time (Peak Season)	<input checked="" type="checkbox"/> within 15 workday <input type="checkbox"/> one month <input type="checkbox"/> 2-3 months <input type="checkbox"/> 4-6 months <input type="checkbox"/> 6-12 months <input type="checkbox"/> more time
Average lead time (Off Season)	<input checked="" type="checkbox"/> within 15 workday <input type="checkbox"/> one month <input type="checkbox"/> 2-3 months <input type="checkbox"/> 4-6 months <input type="checkbox"/> 6-12 months <input type="checkbox"/> more time

Section 2: Export Business Capacity

2.1 Market Distribution (please list top three areas)		
Market	Main Product	Main client
<input checked="" type="checkbox"/> North America	Slip Sheet, Plastic Slip Sheet, Paper Slip Sheet, Anti Slip Paper, Dunnage Bag	Confidential
<input type="checkbox"/> South America		
<input checked="" type="checkbox"/> Europe	Slip Sheet, Plastic Slip Sheet, Paper Slip Sheet, Anti Slip Paper, Dunnage Bag	Confidential
<input checked="" type="checkbox"/> Southeast Asia/ Mideast	Slip Sheet, Plastic Slip Sheet, Paper Slip Sheet, Anti Slip Paper, Dunnage Bag	Confidential
<input type="checkbox"/> Africa		
<input checked="" type="checkbox"/> East Asia (Japan/ South Korea)	Slip Sheet, Plastic Slip Sheet, Paper Slip Sheet, Anti Slip Paper, Dunnage Bag	Confidential
<input checked="" type="checkbox"/> Australia	Slip Sheet, Plastic Slip Sheet, Paper Slip Sheet, Anti Slip Paper, Dunnage Bag	Confidential
<input checked="" type="checkbox"/> Domestic	Slip Sheet, Plastic Slip Sheet, Paper Slip Sheet, Anti Slip Paper, Dunnage Bag	Confidential
<input type="checkbox"/> Others		



Unless otherwise agreed in writing, this document is issued by the Company under its General Conditions of Service accessible at <http://www.sgs.com/en/Terms-and-Conditions.aspx>. Attention is drawn to the limitation of liability, indemnification and jurisdiction issues defined therein. Any holder of this document is advised that information contained hereon is solely limited to visual examination of the safely and readily accessible portions of the consignment and reflects the Company's findings at the time of its intervention only and within the limits of Client's instructions, if any. The Company's sole responsibility is to its Client and this document does not exonerate parties to a transaction from exercising all their rights and obligations under the transaction documents. Any unauthorized alteration, forgery or falsification of the content or appearance of this document is unlawful and offenders may be prosecuted to the fullest extent of the law.

Section 3: Supplier Management

3.1 Supplier Management		
Item	Content	Observations /Comments
1	Does the company establish and implement an effective suppliers' assessment procedure?	<input type="checkbox"/> Have the written procedures and followed records <input checked="" type="checkbox"/> Have the written procedures but no records <input type="checkbox"/> Have relevant records without written procedure <input type="checkbox"/> No written procedures or followed records <input type="checkbox"/> Other
2	Does the company have an updated list of approved suppliers?	<input type="checkbox"/> The approved suppliers list was updated in _____ <input type="checkbox"/> Have the written suppliers without approved signature or date. <input checked="" type="checkbox"/> Provided some suppliers names <input type="checkbox"/> No approved suppliers list <input type="checkbox"/> Other

Section 4: After-sales Service Capacity

4.1 After-sales Service Capacity		
Item	Content	Observations /Comments
1	Is there a procedure to conduct random product inspection after final packaging in place?	<input type="checkbox"/> Have clear standards and written inspection records <input type="checkbox"/> No written standards but had inspection reports <input type="checkbox"/> Have the procedures but no inspection records <input checked="" type="checkbox"/> It's not necessary to carry out the inspection <input type="checkbox"/> Other
2	Is there a clear procedure for handling customer complaints?	<input checked="" type="checkbox"/> Has the clear procedure and followed records <input type="checkbox"/> Has the procedure but no written records. <input type="checkbox"/> No written procedures or records. <input type="checkbox"/> Other
3	Can the finished/packaged product be traced by lot identification to the appropriate raw materials test reports?	<input type="checkbox"/> Have the procedures to trace the raw materials. <input type="checkbox"/> Can trace main materials <input checked="" type="checkbox"/> Can trace production date. <input type="checkbox"/> Can't trace products <input type="checkbox"/> Other
4	Are corrective & preventive actions mechanism established and implemented effectively (including the suppliers/ sub-contractors control, incoming inspection, process control, final inspection and customer complaint)?	<input type="checkbox"/> Has the clear procedure and followed records <input checked="" type="checkbox"/> Has the procedure but no written records. <input type="checkbox"/> No written procedures or records. <input type="checkbox"/> Other



Unless otherwise agreed in writing, this document is issued by the Company under its General Conditions of Service accessible at <http://www.sgs.com/en/Terms-and-Conditions.aspx>. Attention is drawn to the limitation of liability, indemnification and jurisdiction issues defined therein. Any holder of this document is advised that information contained hereon is solely limited to visual examination of the safely and readily accessible portions of the consignment and reflects the Company's findings at the time of its intervention only and within the limits of Client's instructions, if any. The Company's sole responsibility is to its Client and this document does not exonerate parties to a transaction from exercising all their rights and obligations under the transaction documents. Any unauthorized alteration, forgery or falsification of the content or appearance of this document is unlawful and offenders may be prosecuted to the fullest extent of the law.

Part C: Product Research & Development Capacity

1.1 Product Research & Development Capacity	
The amount of R&D and relevant working experience.	<input type="checkbox"/> within 1 year staff <input type="checkbox"/> 1-5 years staff <input type="checkbox"/> 6-10 years staff <input checked="" type="checkbox"/> over 10 years 2 staffs Total 2 engineers
What is the main job responsibility for R&D engineers?	R&D new product and also support technology services for producing scene
Is there any relevant design input, output, review, verification and validation documentation available for auditor to review?	The company didn't provide relevant records to review due to commercial secret.
Is there any special software or instrument used by the R&D staffs during the design process of new products? If yes, please list the main software or instrument.	The company didn't provide relevant records to review due to commercial secret.
Does the company have an effective design change control procedure in place?	The company didn't provide relevant records to review due to commercial secret.
Please list the patent certificates and qualification license.	Nil



Unless otherwise agreed in writing, this document is issued by the Company under its General Conditions of Service accessible at <http://www.sgs.com/en/Terms-and-Conditions.aspx>. Attention is drawn to the limitation of liability, indemnification and jurisdiction issues defined therein. Any holder of this document is advised that information contained hereon is solely limited to visual examination of the safely and readily accessible portions of the consignment and reflects the Company's findings at the time of its intervention only and within the limits of Client's instructions, if any. The Company's sole responsibility is to its Client and this document does not exonerate parties to a transaction from exercising all their rights and obligations under the transaction documents. Any unauthorized alteration, forgery or falsification of the content or appearance of this document is unlawful and offenders may be prosecuted to the fullest extent of the law.

Part D: Management System and Product Certification

1.1 Management System and Product Certification	
Management system certification	<input checked="" type="checkbox"/> ISO9001:2015 certificate Certificate Name:ISO9001:2015 Certificate NO.: 11722QU0299-07R0S Issued by: Shanghai Ingeer Certification Assessment Co., Ltd Issued Date: 22 Jul.,2022 Valid Until: 21 Jul.,2025 Scope: Production of Slip Sheet, Dunnage Air Bag
Product certification	<input type="checkbox"/> CE <input type="checkbox"/> UL <input type="checkbox"/> CCC <input type="checkbox"/> RoHS <input type="checkbox"/> FCC <input checked="" type="checkbox"/> Others Certificate Name: FSC NO.: FCOC46389 Product Name: N/A Model: Composite papers P2.4.10; Continuous pressure laminates (CPL) 3.4.3 Claim: FSC 100%, FSC Mix, FSC Recycled Standard: FSC-STD-40-004 V3-1 & FSC-STD-50-001 V2-0 Scope: Tracking of wood based material Issued by: asi Issue Date: 08 Jun.,2022 <input type="checkbox"/> NIL
Test reports for raw materials	<input type="checkbox"/> RoHS <input type="checkbox"/> Reach <input type="checkbox"/> Others <input checked="" type="checkbox"/> NIL



Unless otherwise agreed in writing, this document is issued by the Company under its General Conditions of Service accessible at <http://www.sgs.com/en/Terms-and-Conditions.aspx>. Attention is drawn to the limitation of liability, indemnification and jurisdiction issues defined therein. Any holder of this document is advised that information contained hereon is solely limited to visual examination of the safely and readily accessible portions of the consignment and reflects the Company's findings at the time of its intervention only and within the limits of Client's instructions, if any. The Company's sole responsibility is to its Client and this document does not exonerate parties to a transaction from exercising all their rights and obligations under the transaction documents. Any unauthorized alteration, forgery or falsification of the content or appearance of this document is unlawful and offenders may be prosecuted to the fullest extent of the law.

Page No.: 8 of 16

Part E: Production Capacity & Quality Control

Section 1: Production Capacity

1.1 Production Workflow Chart

Production Workflow Chart of Plastic Slip Sheet

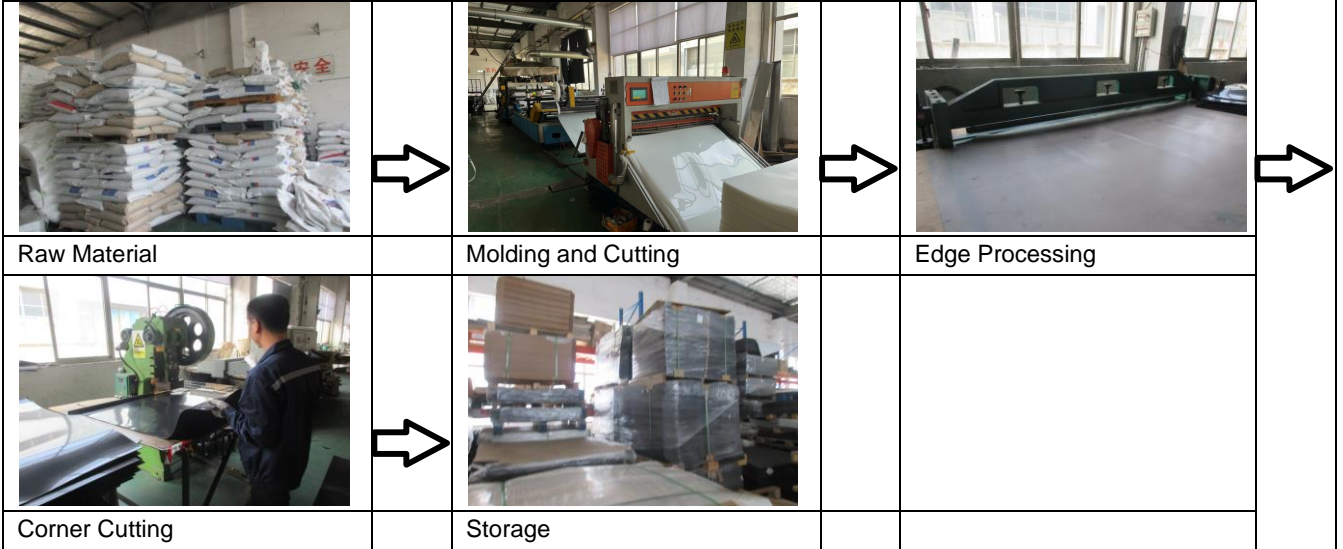

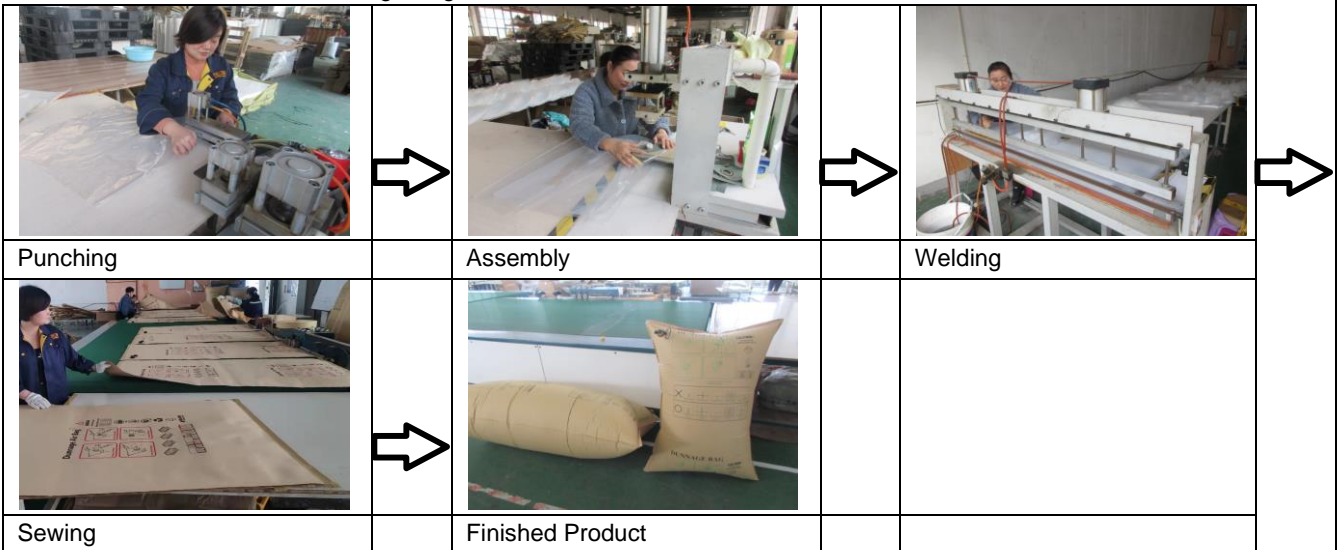

Production Workflow Chart of Dunnage Bag



Unless otherwise agreed in writing, this document is issued by the Company under its General Conditions of Service accessible at <http://www.sgs.com/en/Terms-and-Conditions.aspx>. Attention is drawn to the limitation of liability, indemnification and jurisdiction issues defined therein. Any holder of this document is advised that information contained hereon is solely limited to visual examination of the safely and readily accessible portions of the consignment and reflects the Company's findings at the time of its intervention only and within the limits of Client's instructions, if any. The Company's sole responsibility is to its Client and this document does not exonerate parties to a transaction from exercising all their rights and obligations under the transaction documents. Any unauthorized alteration, forgery or falsification of the content or appearance of this document is unlawful and offenders may be prosecuted to the fullest extent of the law.

1.2 Products Situation (Top three Product Categories)

Product	Price range	Min. order quantity	Top monthly output	Average monthly output	Total in
 Dunnage Bag	Confidential	500 Pcs	Confidential	Confidential	Confidential
 Plastic Slip Sheet	Confidential	2,000 Pcs	Confidential	Confidential	Confidential

1.3 Main Facilities

Picture	Facility name	Brand or Country/Region of origin	Target Value/machine*day	Quantity
	Injection Molding & Cutting Line	Confidential	Confidential	2
	Punching Machine	China	Confidential	2
	Assembly Machine	China	Confidential	2
	Auto Sewing Machine	China	Confidential	2
	Welding Machine	China	Confidential	2
	Edge Processing Machine	China	Confidential	1



Unless otherwise agreed in writing, this document is issued by the Company under its General Conditions of Service accessible at <http://www.sgs.com/en/Terms-and-Conditions.aspx>. Attention is drawn to the limitation of liability, indemnification and jurisdiction issues defined therein. Any holder of this document is advised that information contained hereon is solely limited to visual examination of the safely and readily accessible portions of the consignment and reflects the Company's findings at the time of its intervention only and within the limits of Client's instructions, if any. The Company's sole responsibility is to its Client and this document does not exonerate parties to a transaction from exercising all their rights and obligations under the transaction documents. Any unauthorized alteration, forgery or falsification of the content or appearance of this document is unlawful and offenders may be prosecuted to the fullest extent of the law.

Page No.: 10 of 16

 SGS-CSI Standards Technical Services Co., Ltd.
 Consumer and Producer Services

 5/F, B-4 Building, Zijin (Baixia) Technology Incubation Special Park, No.1 Guanghua Road, Nanjing, China 210014 t (86-25) 87128385 f (86-25) 83407773 www.sgs.com.cn
 中国·南京·秦淮区光华路1号紫金白下创业特别社区4号楼B幢5楼 邮编: 210014 t (86-25) 87128385 f (86-25) 83407773 e as.cn@sgs.com

	Corner Cutting Machine	China	Confidential	2
	Paper Cutter	China	Confidential	1
	Gumming Machine	China	Confidential	1



Unless otherwise agreed in writing, this document is issued by the Company under its General Conditions of Service accessible at <http://www.sgs.com/en/Terms-and-Conditions.aspx>. Attention is drawn to the limitation of liability, indemnification and jurisdiction issues defined therein. Any holder of this document is advised that information contained hereon is solely limited to visual examination of the safely and readily accessible portions of the consignment and reflects the Company's findings at the time of its intervention only and within the limits of Client's instructions, if any. The Company's sole responsibility is to its Client and this document does not exonerate parties to a transaction from exercising all their rights and obligations under the transaction documents. Any unauthorized alteration, forgery or falsification of the content or appearance of this document is unlawful and offenders may be prosecuted to the fullest extent of the law.

Section 2: Production Process Control

2.1 Production Process Control		
Item	Content	Observations /Comments
1	Product R&D capacity	<input type="checkbox"/> Own brand <input checked="" type="checkbox"/> ODM <input checked="" type="checkbox"/> OEM
2	Are the environmental conditions, such as tidiness and cleanliness being controlled and suitable for the operation performed?	<input type="checkbox"/> Very tidy <input checked="" type="checkbox"/> Normal <input type="checkbox"/> Need to improve <input type="checkbox"/> Very poor
3	Are the necessary items /documents provided at appropriate location and under control?	<input checked="" type="checkbox"/> Work Instructions /procedures <input type="checkbox"/> Workmanship standard /acceptance <input type="checkbox"/> Golden sample /Approval sample <input type="checkbox"/> Product picture <input type="checkbox"/> Verbal by workshop director
4	Are written instructions available for incoming material inspections /testing? Is the relevant record maintained?	<input checked="" type="checkbox"/> Has instructions and uniformly followed <input type="checkbox"/> Has instruction but no written records <input type="checkbox"/> Materials checked by storage staff
5	Are written inspections /testing instructions available for finished products? Is the relevant record maintained?	<input checked="" type="checkbox"/> Have instructions and uniformly followed <input type="checkbox"/> Have instruction but no written records <input type="checkbox"/> Finished product checked by packing staff
6	What type of inspection is used for finished products?	<input checked="" type="checkbox"/> Random inspection <input checked="" type="checkbox"/> Visual inspection <input checked="" type="checkbox"/> Function inspection <input type="checkbox"/> 100% inspection <input type="checkbox"/> Visual inspection <input type="checkbox"/> Function inspection
7	Are non-conforming units clearly marked/ segregated to prevent accidental dispatch?	<input checked="" type="checkbox"/> Marked and segregated <input type="checkbox"/> Segregated but not marked clearly <input type="checkbox"/> Not found on site
8	How are the non-conforming units handled?	<input type="checkbox"/> Repaired and re-inspection <input checked="" type="checkbox"/> Picked out <input type="checkbox"/> Used under control <input type="checkbox"/> Others



Unless otherwise agreed in writing, this document is issued by the Company under its General Conditions of Service accessible at <http://www.sgs.com/en/Terms-and-Conditions.aspx>. Attention is drawn to the limitation of liability, indemnification and jurisdiction issues defined therein. Any holder of this document is advised that information contained hereon is solely limited to visual examination of the safely and readily accessible portions of the consignment and reflects the Company's findings at the time of its intervention only and within the limits of Client's instructions, if any. The Company's sole responsibility is to its Client and this document does not exonerate parties to a transaction from exercising all their rights and obligations under the transaction documents. Any unauthorized alteration, forgery or falsification of the content or appearance of this document is unlawful and offenders may be prosecuted to the fullest extent of the law.

Part G: Working Environment

Section 1: Working Environment

1.1 Welfare Benefits		
Item	Content	Observations /Comments
1	Does the company have effective procedures to verify the age of staff at the time of recruitment?	<input checked="" type="checkbox"/> Has written procedure and keeps adequate age documents of workers <input type="checkbox"/> Has written procedure but doesn't follow records <input type="checkbox"/> Hasn't written procedure or follows records
2	Do all workers sign employment contracts with the factory?	<input checked="" type="checkbox"/> All workers sign employment contracts <input type="checkbox"/> Some workers sign employment contracts <input type="checkbox"/> Only management staff sign employment contracts <input type="checkbox"/> No staff sign employment contracts
3	Is statutory contribution required for all employees' social insurance (e.g. health insurance, unemployment insurance, accident insurance etc.) paid for by the enterprise?	<input type="checkbox"/> All workers have social insurance. <input checked="" type="checkbox"/> Some workers have social insurance <input type="checkbox"/> Only management staffs have social insurance <input type="checkbox"/> No staff have social insurance
4	Does the company have a clear and effective policy on working hours, rest and vacations? If does, please list it.	<input checked="" type="checkbox"/> All staffs work kept to the policy <input type="checkbox"/> Most of the time it keeps to the policy except midseason. <input type="checkbox"/> Usually needs overtime. <input type="checkbox"/> No relevant records for working hours Describe the working hours: 8 hours per day
5	Does the company pay extra remunerations for all overtime work?	<input checked="" type="checkbox"/> For all overtime work. <input type="checkbox"/> For official holidays <input type="checkbox"/> For official holidays except weekend. <input type="checkbox"/> No extra remunerations for overtime.
6	Does the company have dormitories for staff? If yes, please describe the condition.	<input type="checkbox"/> Provide dormitories for all staff <input type="checkbox"/> Provide dormitories for workers <input type="checkbox"/> Provide dormitories for management staff <input checked="" type="checkbox"/> No dormitories were provided. Describe the condition:
1.2 Labor Protection		
Item	Content	Observations /Comments
1	Are there uniforms for all staff in company?	<input checked="" type="checkbox"/> Yes <input type="checkbox"/> No <input type="checkbox"/> Other
2	Is the emergency medical supplies enough and easily used in workshop?	<input checked="" type="checkbox"/> Yes <input type="checkbox"/> No <input type="checkbox"/> Other
3	Does the company arrange health and safety training for new workers?	<input checked="" type="checkbox"/> Yes <input type="checkbox"/> No <input type="checkbox"/> Other
4	Do the workers have the appropriate protective equipment during operation in workshop? Such as gloves, masks.	<input checked="" type="checkbox"/> Yes <input type="checkbox"/> No <input type="checkbox"/> Other
5	Is there training needed and carried out for fire protection?	<input checked="" type="checkbox"/> Yes <input type="checkbox"/> No <input type="checkbox"/> Other



Unless otherwise agreed in writing, this document is issued by the Company under its General Conditions of Service accessible at <http://www.sgs.com/en/Terms-and-Conditions.aspx> Attention is drawn to the limitation of liability, indemnification and jurisdiction issues defined therein. Any holder of this document is advised that information contained hereon is solely limited to visual examination of the safely and readily accessible portions of the consignment and reflects the Company's findings at the time of its intervention only and within the limits of Client's instructions, if any. The Company's sole responsibility is to its Client and this document does not exonerate parties to a transaction from exercising all their rights and obligations under the transaction documents. Any unauthorized alteration, forgery or falsification of the content or appearance of this document is unlawful and offenders may be prosecuted to the fullest extent of the law.

Part H: Energy Saving and Emission Reduction

Section 1: Environmental Management

1.1 Environmental Management		
Item	Content	Observations /Comments
1	Environmental Management System	<input type="checkbox"/> ISO 14001 Certificate <input type="checkbox"/> Cleaner production management <input checked="" type="checkbox"/> NIL
2	Environmental Impact Assessment	<input type="checkbox"/> The Report of Environmental impact assessment is approved by EPA . <input checked="" type="checkbox"/> NIL
3	Check and Acceptance of Completed Constructive Projects	<input type="checkbox"/> The Report Completed Constructive Projects Inspection and Acceptance is approved. <input checked="" type="checkbox"/> NIL
4	"Three Simultaneity" for Environmental protection	<input type="checkbox"/> The Report of "Three Simultaneity" for Environmental protection Inspection and Acceptance is available. <input checked="" type="checkbox"/> NIL

Section 2: Water, Gas and Noise Control

2.1 Water, Gas and Noise Control		
Item	Content	Observations /Comments
1	Water-intaking	<input type="checkbox"/> Water-intaking license <input type="checkbox"/> No water-intaking license <input checked="" type="checkbox"/> No water taken from natural water body
2	Waste water	<input type="checkbox"/> Water-draining license or contract <input type="checkbox"/> Having carried out waste water treatment before draining <input type="checkbox"/> Having carried out waste water monitoring and the result of which being within the standard limit <input checked="" type="checkbox"/> No detail activities were found
3	Emission to air	<input type="checkbox"/> Air pollutant emission license <input type="checkbox"/> Having carried out air pollutant emission monitoring and the result of which being within the standard limit <input checked="" type="checkbox"/> No detail activities were found to reduce emission to air
4	Classification and Recycling for solid waste	<input type="checkbox"/> Having applied trash classification recycling <input type="checkbox"/> Having special warehouse for hazardous waste <input checked="" type="checkbox"/> No detail activities were found
5	Noise	<input type="checkbox"/> The company carried out noise monitoring and the result of which being within the standard limit one time per year <input checked="" type="checkbox"/> No detail activities were found



Unless otherwise agreed in writing, this document is issued by the Company under its General Conditions of Service accessible at <http://www.sgs.com/en/Terms-and-Conditions.aspx>. Attention is drawn to the limitation of liability, indemnification and jurisdiction issues defined therein. Any holder of this document is advised that information contained hereon is solely limited to visual examination of the safely and readily accessible portions of the consignment and reflects the Company's findings at the time of its intervention only and within the limits of Client's instructions, if any. The Company's sole responsibility is to its Client and this document does not exonerate parties to a transaction from exercising all their rights and obligations under the transaction documents. Any unauthorized alteration, forgery or falsification of the content or appearance of this document is unlawful and offenders may be prosecuted to the fullest extent of the law.

Page No.: 14 of 16

Part J: Photos

Section 1: Photos of Documents

1.1 Photos of Documents

Description: Business License



Description: Export License



Description: FSC Certification



Description: ISO9001 Certification



Unless otherwise agreed in writing, this document is issued by the Company under its General Conditions of Service accessible at <http://www.sgs.com/en/Terms-and-Conditions.aspx>. Attention is drawn to the limitation of liability, indemnification and jurisdiction issues defined therein. Any holder of this document is advised that information contained hereon is solely limited to visual examination of the safely and readily accessible portions of the consignment and reflects the Company's findings at the time of its intervention only and within the limits of Client's instructions, if any. The Company's sole responsibility is to its Client and this document does not exonerate parties to a transaction from exercising all their rights and obligations under the transaction documents. Any unauthorized alteration, forgery or falsification of the content or appearance of this document is unlawful and offenders may be prosecuted to the fullest extent of the law.

Section 2: Photos of Company

2.1 Photos of Company and Product Sample

Description: Company Gate



Description: Office



Description: Workshop



Description: Workshop



-- End of the Report --



SGS-CSI Standards Technical Services Co., Ltd.
Consumer and Producer Services

Unless otherwise agreed in writing, this document is issued by the Company under its General Conditions of Service accessible at <http://www.sgs.com/en/Terms-and-Conditions.aspx>. Attention is drawn to the limitation of liability, indemnification and jurisdiction issues defined therein. Any holder of this document is advised that information contained hereon is solely limited to visual examination of the safely and readily accessible portions of the consignment and reflects the Company's findings at the time of its intervention only and within the limits of Client's instructions, if any. The Company's sole responsibility is to its Client and this document does not exonerate parties to a transaction from exercising all their rights and obligations under the transaction documents. Any unauthorized alteration, forgery or falsification of the content or appearance of this document is unlawful and offenders may be prosecuted to the fullest extent of the law.

Page No.: 16 of 16

5/F, B-4 Building, Zijin (Baixia) Technology Incubation Special Park, No.1 Guanghua Road, Nanjing, China 210014 t (86-25) 87128385 f (86-25) 83407773 www.sgs.com.cn
中国·南京·秦淮区光华路1号紫金白下创业特别社区4号楼B幢5楼 邮编: 210014 t (86-25) 87128385 f (86-25) 83407773 e as.cn@sgs.com