

中国工信部高精度传感器一条龙应用计划示范项目

国家级专精特新“小巨人”企业，国家级高新技术企业

中国工业强基重点产品，中国工信部传感器一条龙应用计划示范企业

电涡流位移传感器

Eddy Current Displacement Sensor

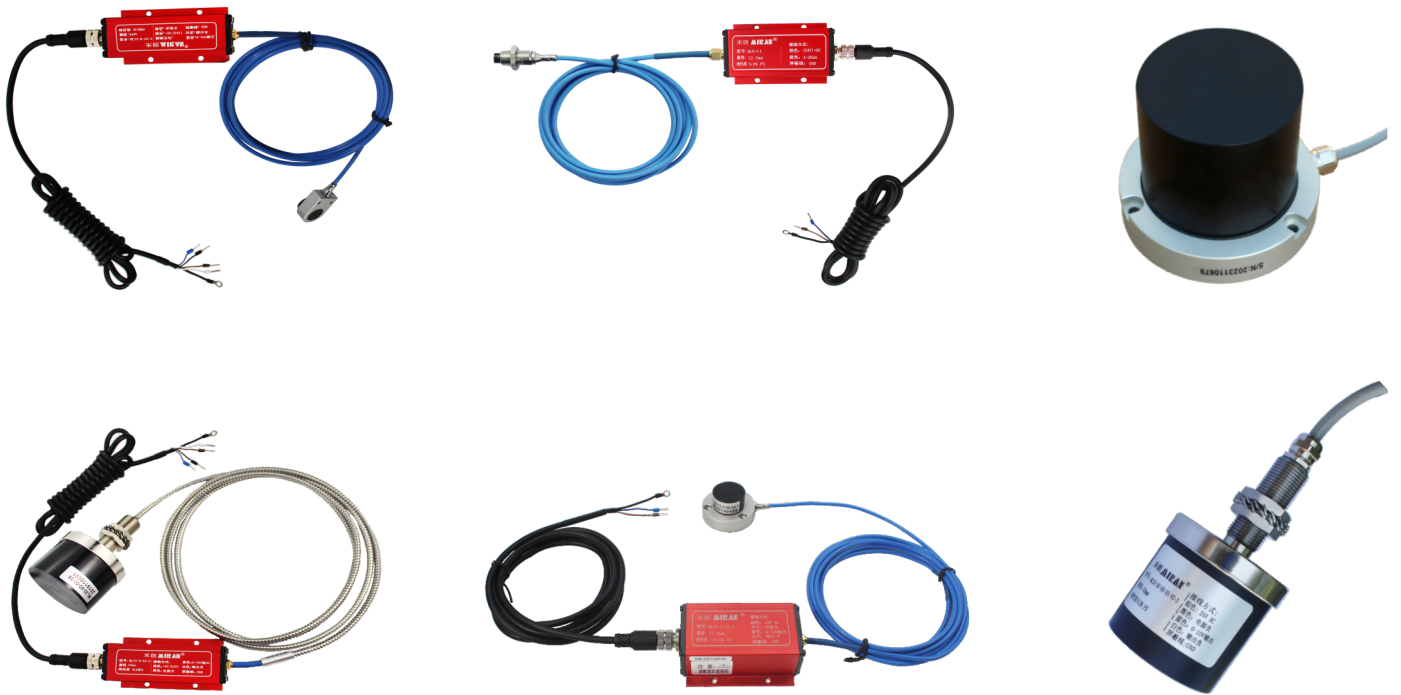

电涡流位移传感器

Eddy current displacement sensor

- Demonstration project of one-stop application plan for high-precision sensors of Ministry of Industry and Information Technology of China
- National level specialized and special new "little giant" enterprise, national level high-tech enterprise
- Key products of strong industrial base in China, demonstration enterprise of sensor one-stop application plan of Ministry of Industry and Information Technology of China

目录CONTENTS

● 分体式电涡流传感器系列

Split Type Eddy Current Displacement Sensor Series

- 产品实物图 Product physical pictures 03
- 工作原理 Working principle 04
- 应用案例 Application cases 05
- 技术参数 Technical parameter 05
- 产品规格 Product specifications 07
- 产品选型 Product selection 12

● 一体式电涡流位移传感器

Integrated Eddy Current Displacement Sensor

- 产品实物图 Product physical pictures 14
- 工作原理 Working principle 15
- 技术参数 Technical parameter 15
- 产品选型 Product selection 16
- 安装尺寸图 Drawing 17

● 非标专区(电涡流位移传感器)

Non Standard Zone(Eddy Current Displacement Sensor)

● MDW-01电涡流传感器 MDW-01 Eddy Current Sensor

- 产品实物图 Product physical pictures 18
- 安装尺寸图 Drawing 18
- 工作原理 Working principle 19
- 技术参数 Technical parameter 19

● 集成式电涡流传感器 Integrated Eddy Current Sensor

- 产品实物图 Product physical pictures 20
- 安装尺寸图 Drawing 20

● 电涡流传感器安装使用 Installation And Use Of Eddy Current Sensors

- 探头的安装 Installation of probes 21
- 安装注意事项 Installation precautions 25

● 出厂检测报告 Ex-works Inspection Reports 29

分体式电涡流位移传感器

Split Type Eddy Current Displacement Sensor

产品实物图 Product Physical Image

标准式探头 Standard probe



沉头式探头 Countersunk probe

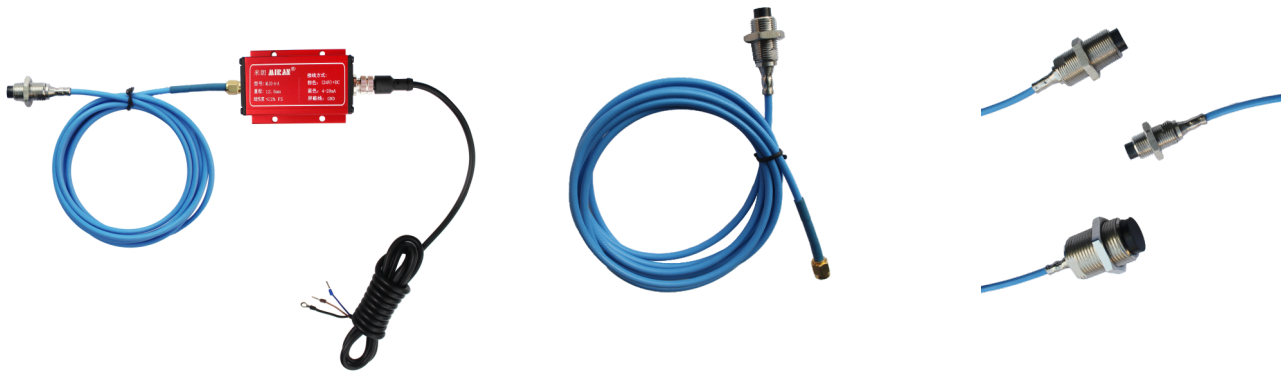

方形式探头 Square shaped probe



圆形式探头Circular probe



工作原理Working Principle

电涡流传感器系统的工作原理是电涡流效应，属于一种电感式测量原理。电涡流效应源自振荡电路的能量。而电涡流需要在可导电的材料内才可以形成。给传感器探头内线圈导入一个交变电流，可以在探头线圈周围形成一个磁场。如果将一个导体放入这个磁场，根据法拉第电磁感应定律，导体内会激发出电涡流。根据楞兹定律，电涡流的磁场方向与线圈磁场正好相反，而这将改变探头内线圈的阻抗值。这个阻抗值的变化与线圈到被测物体之间的距离直接相关。传感器探头连接到控制器后，控制器可以从传感器探头内获得电压值的变化量，并以此为依据，计算出对应的距离值，电涡流测量原理可以测量所有导电材料。

由于电涡流可以穿透绝缘体，即使表面覆盖有绝缘体的金属材料，也可以作为电涡流传感器的被测物体。独特的圈式绕组设计在实现传感器外形极致紧凑的同时，可以满足其运转于高温测量环境的要求。

The working principle of an eddy current sensor system is the eddy current effect, which belongs to an inductive measurement principle. The eddy current effect originates from the energy of the oscillating circuit. And eddy currents need to be formed within conductive materials. Introducing an alternating current into the coil inside the sensor probe can create a magnetic field around the probe coil. If a conductor is placed in this magnetic field, according to Faraday's law of electromagnetic induction, eddy currents will be excited inside the conductor. According to Lenz's law, the direction of the magnetic field of the eddy current is exactly opposite to the magnetic field of the coil, which will change the impedance value of the coil inside the probe. The change in impedance value is directly related to the distance between the coil and the object being measured. After the sensor probe is connected to the controller, the controller can obtain the change in voltage value from the sensor probe and calculate the corresponding distance value based on this. The principle of eddy current measurement can measure all conductive materials. Due to the ability of eddy currents to penetrate insulators, even metal materials covered with insulators can be used as the tested object for eddy current sensors. The unique coil winding design not only achieves an extremely compact appearance of the sensor, but also meets its requirements for operating in high-temperature measurement environments.

应用案例 Application Cases

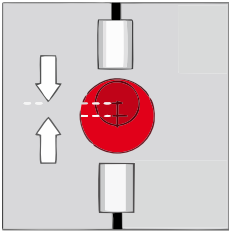

偏心度, 直径, 同心度
Eccentricity, diameter, concentricity

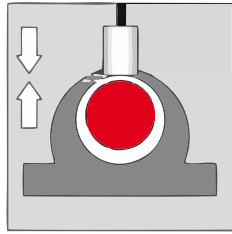

轴承震动, 润滑油间隙, 磨损
Bearing vibration, lubrication oil clearance, wear

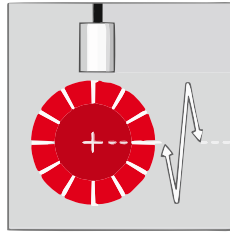

集流器同心度, 圆度, 空气间隙
Concentricity, roundness, and air gap of the collector

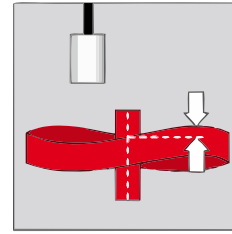

冲程, 变形, 轴向主轴震动
Stroke, deformation, axial spindle vibration

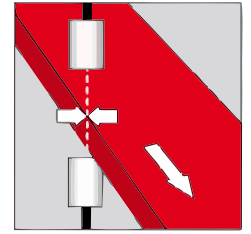

延边控制, 定位, 宽度
Extension control, positioning, width

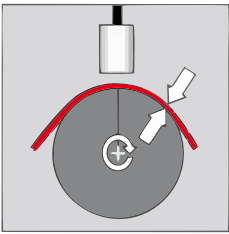

薄膜, 镀层, 型材厚度
Film, coating, profile thickness

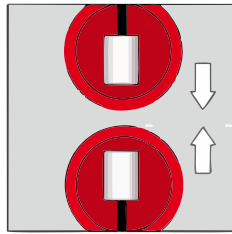

压辊间隙, 压辊变形, 凸面
Gap between pressure rollers, deformation of pressure rollers, convex surface

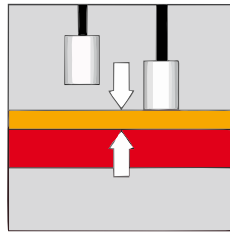

薄膜, 橡胶, 绝缘层的厚度
Thickness of film, rubber, and insulation layer

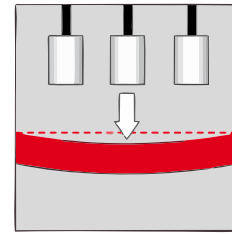

挠曲, 变形, 波形
Flexion, deformation, waveform

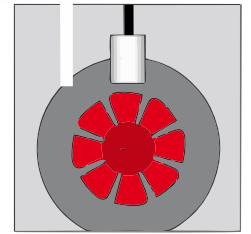

压缩机/引擎间隙, 转数
Compressor/engine clearance, RPM

技术参数 Technical Parameter

接线定义 Wiring Definition

	棕色 BROWN	黑色 BLACK	蓝色 BLUE	白色 WHITE	屏蔽线 Shielding wire
电流二线制接线方式 Current three wire connection	电源正 Power Positive +24VDC	/	电流输出 current output	/	接大地 GROUNDING GND
	棕色 BROWN	黑色 BLACK	蓝色 BLUE	白色 WHITE	屏蔽线 Shielding wire
电流三线制接线方式 Current two wire connection	电源正 Power Positive +24VDC	电源负 0V Power Negative 输出- OUT-	电流输出 current output	/	接大地 GROUNDING GND
	棕色 BROWN	黑色 BLACK	蓝色 BLUE	白色 WHITE	屏蔽线 Shielding wire
电压接线方式 Voltage wiring method	+12VDC 或OR +24VDC	电源负 Power Negative 0V	输出+ OUT+	输出- OUT-	接大地 GROUNDING GND
	棕色 BROWN	黑色 BLACK	蓝色 BLUE	白色 WHITE	屏蔽线 Shielding wire
数字信号接线方式 Digital signal wiring method RS485	电源正 Power Positive +12~24VDC	电源负 Power Negative 0V	RS485 A+	RS485 B-	接大地 GROUNDING GND

以上仅为参考, 具体接线定义以产品实物标签上的标注为准。

The above is for reference only. The specific cable definition is subject to the mark on the physical label of the product

技术参数 Technical Parameter

本资料所列的电气参数，是在环境温度20度时候的值。

The electrical parameters listed in this document are the values at an ambient temperature of 20 degrees.

电气指标 Electrical specifications

测量量程 Measurement range	1mm	2mm	4mm	5mm	12.5mm	20mm	25mm	50mm
探头直径(标准式) Probe diameter (standard formula)	φ6mm	φ8mm	φ11mm	φ17mm	φ30mm	φ40mm	φ50mm	φ60mm
探头直径(沉头式) Probe diameter (countersunk)	φ8mm	φ8mm	φ11mm	φ17mm	/	/	/	/
探头直径(方形式) Probe diameter (in square form)	φ8mm	φ8mm	φ13mm	φ19mm	/	/	/	/
探头直径(圆形式) Probe diameter (circular)	/	/	/	/	φ30mm	φ40mm	φ50mm	φ60mm
线性误差 (%FS) Linear error (%FS)	≤±0.25	≤±0.25	≤±0.5	≤±0.5	≤±1	≤±1	≤±1	≤±2
重复性 Repeatability	0.5um	0.5um	1um	1um	2um	2~4um	2~4um	2~5um
频率响应 Frequency response	0~10KHz		0~8KHz		0~2KHz	0~1KHz		
输出信号 Output signal	0~5V, 0~10V, 4~20mA, RS485							
供电电压 Supply Voltage	电压型: +9~36VDC 或 ±15VDC (可选) Voltage type: +9-36VDC or ±15VDC (optional)			电流型: +22~30VDC Current type: +22-30VDC		RS485型: +12VDC Rs485 type: +22-30VDC		
工作电流 Working current	电压型: <45mA Voltage type: <45mA			电流型: <25mA Current type: <25mA		RS485型: <40mA Rs485 type: <40mA		

分辨率 Resolution ratio

探头直径 Probe diameter	φ6mm	φ8mm	φ11mm/φ13mm	φ17mm/φ19mm	φ30mm	φ40mm	φ50mm	φ60mm
信号输出 Output								
0-10V电压输出 0-10V voltage output	0.1μm	0.1μm	0.2μm	0.5μm	1.0μm	2.0μm	2.0μm	2.5μm
0-5V电压输出 0-5V voltage output	0.5μm	0.5μm	1.0μm	1.0μm	2.0μm	4.0μm	4.0μm	5.0μm
4-20mA电流输出 4-20mA current output	0.1μm	0.1μm	0.2μm	0.2μm	0.5μm	1.0μm	1.0μm	2.0μm
Rs485数字输出 RS485 digital output	16bit							

性能指标 Performance index

波纹 Corrugation	≤20mV
系统温漂 System temperature drift	根据输出信号和对应量程等因素而定 Determined by factors such as output signal and corresponding range
静态灵敏度 Static sensitivity	根据输出信号和对应量程等因素而定 Determined by factors such as output signal and corresponding range
探头电缆 Probe cable	默认2m, 可定制 Default 2m, customizable
电源电缆 Power cable	默认2m, 可定制 Default 2m, customizable
标定时环境温度 Environmental temperature during calibration	(20±5)°C

机械指标 Mechanical indicators

防护等级 Protection grade	探头 IP67 Probe IP67
	前置器 IP65 Proximitator IP65
输出负载 Output Load	电压输出: 负载能力 <10KΩ Proximitator IP65 voltage output: load capacity < 10KΩ
	电流输出: 负载能力 <500Ω Current output: Load capacity < 500Ω
使用温度 Operating temperature	探头: -30°C~+110°C Probe: -30°C~+110°C
	前置器: -30°C~+85°C Proximitator: -30°C~+85°C

产品规格 Product Specifications

⚡ 探头:ML33传感器系统有探头、前置器、电缆以及附件组成
 Probe:The ML33 sensor system consists of a probe, a preamplifier, cables, and accessories

(1) 标准型探头 Standard type probe

通常探头由线圈、头部、壳体、高频电缆、高频接头组成，其典型结构见图所示。

Usually, the probe consists of a coil, head, shell, high-frequency cable, and high-frequency connector, and its typical structure is shown in the figure.

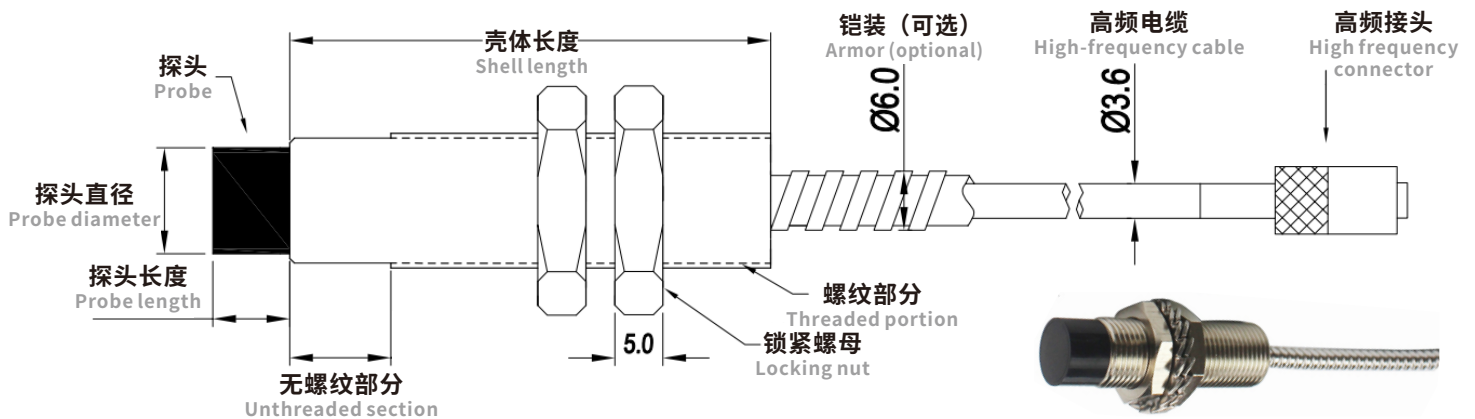

探头典型结构图示（标准型）
 Typical structure diagram of the probe (standard type)

在制作过程中，探头头部体一般采用耐高温PPS工程塑料，通过“二次注塑”成型将线圈密封其中。使探头在恶劣的环境中能可靠工作。由于头部体线圈直径决定传感器系统的线性量程，因此我们通常用头部体外部直径来分类和表征各型号探头，一般情况下传感器系统的线性量程大致是探头头部直径1/2~1/4倍。

During the production process, the probe head body is generally made of high-temperature resistant PPS engineering plastic, and the coil is sealed inside through secondary injection molding. Enable the probe to work reliably in harsh environments. Due to the fact that the diameter of the head coil determines the linear range of the sensor system, we usually use the outer diameter of the head to classify and characterize various types of probes. Generally, the linear range of the sensor system is approximately 1/2 to 1/4 times the diameter of the probe head.

产品规格 Product Specifications

ML33系列传感器探头（标准型）总共有Φ6、Φ8、Φ11、Φ17、Φ30、Φ40、Φ50、Φ60共8种。

There are a total of ML33 series sensor probes (standard type) Φ 6, Φ 8, Φ 11, Φ 17, Φ 30, Φ 40, Φ 50, Φ 60. There are a total of 8 types.

量程 Range	探头直径 Probe diameter	探头长度 Probe length	壳体长度 Shell length	安装类型 Installation type	螺纹规格 Thread specification
1mm	φ6mm	5mm	30mm	标准 Standard	M8X1.0
2mm	φ8mm	7mm	30mm	标准 Standard	M9X1.0
4mm	φ11mm	8mm	50mm	标准 Standard	M14X1.5
5mm	φ17mm	11mm	50mm	标准 Standard	M18X1.0
12.5mm	φ30mm	26mm	40mm	反装 Reverse-mounting	M14X1.5
20mm	φ40mm	33mm	40mm	反装 Reverse-mounting	M14X1.5
25mm	φ50mm	42mm	50mm	反装 Reverse-mounting	M18X1.5
50mm	φ60mm	47mm	50mm	反装 Reverse-mounting	M18X1.5

注：探头壳体用于连接和固定探头头部，并用为探头安装时的装夹结构。

壳体一般采用不锈钢工艺制成，上面刻有标准螺纹，并备有锁紧螺母。

为了能适应不同的应用和安装场合，探头壳体具有不同的形式和不同的螺纹及尺寸规格。

Attention:

The probe housing is used to connect and fix the probe head, and is used as a clamping structure for probe installation. The shell is generally made of stainless steel technology, with standard threads engraved on it and equipped with locking nuts.

In order to adapt to different applications and installation scenarios, the probe housing has different forms, threads, and size specifications.

产品规格 Product Specifications

(2) 沉头式探头 Countersunk probe

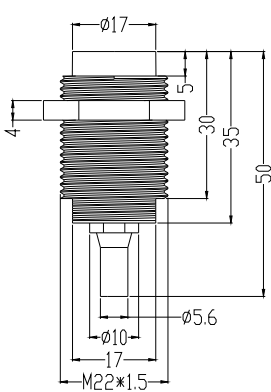
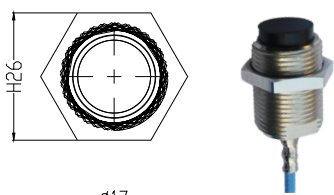

(5mm量程)
(5mm range)

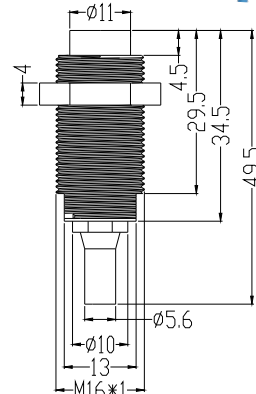
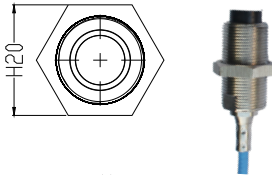

(4mm量程)
(4mm range)

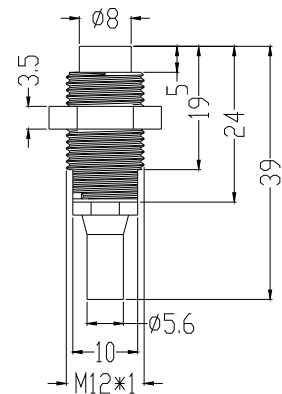
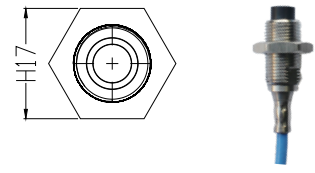

(1-2mm量程)
(1-2mm range)

(3) 方形式探头 Square shaped probe

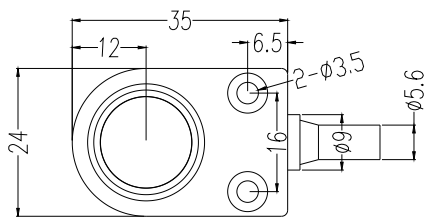

(5mm量程 Range)

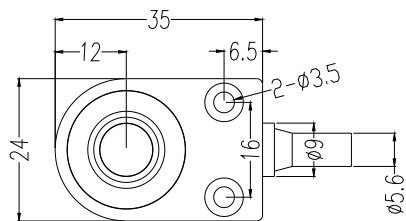
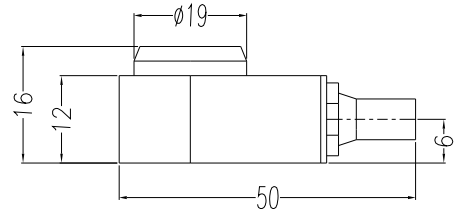

(4mm量程 Range)

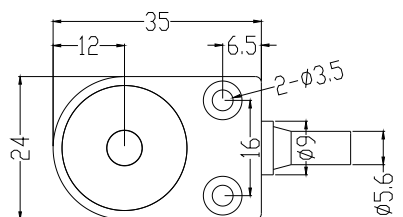
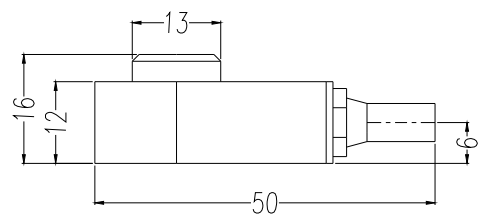

(1-2mm量程 Range)

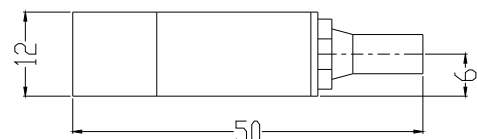

产品规格 Product Specifications

(4) 圆形式探头 Circular probe

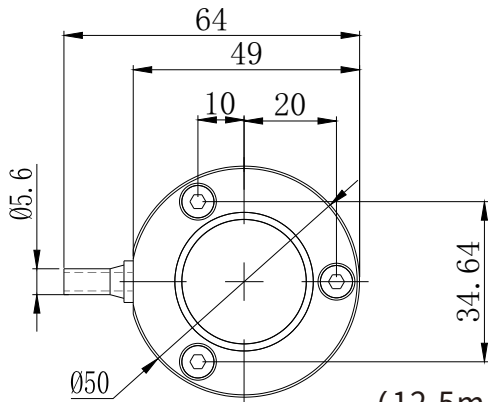

(12.5mm量程 Range)

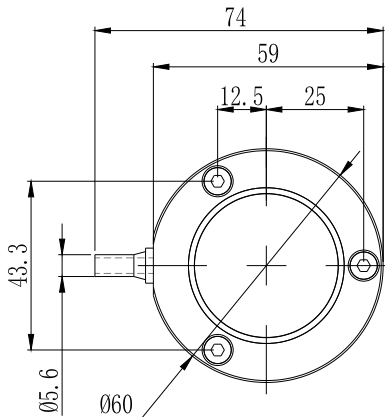
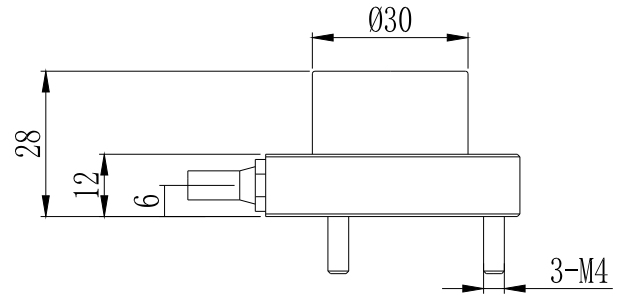

(20mm量程 Range)

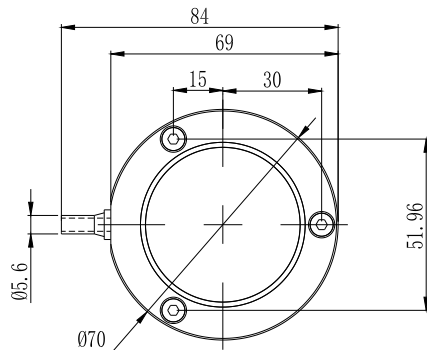
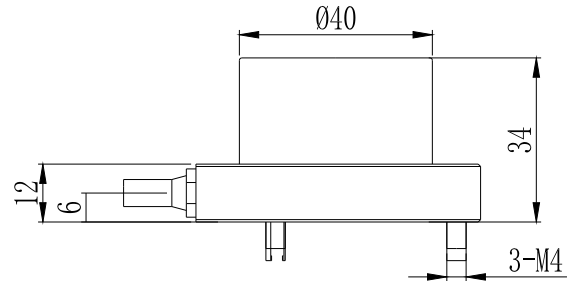

(25mm量程 Range)

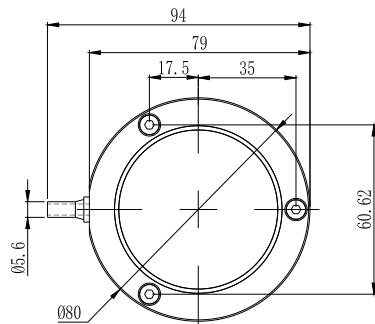
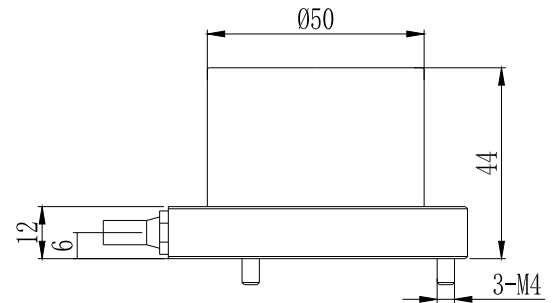

(50mm量程 Range)

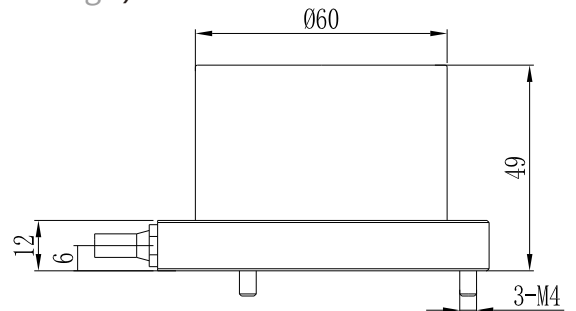

产品规格 Product Specifications

前置器: ML33系列前置器外形尺寸图

Proximitior: ML33 series Proximitior Outline Dimensional Drawing

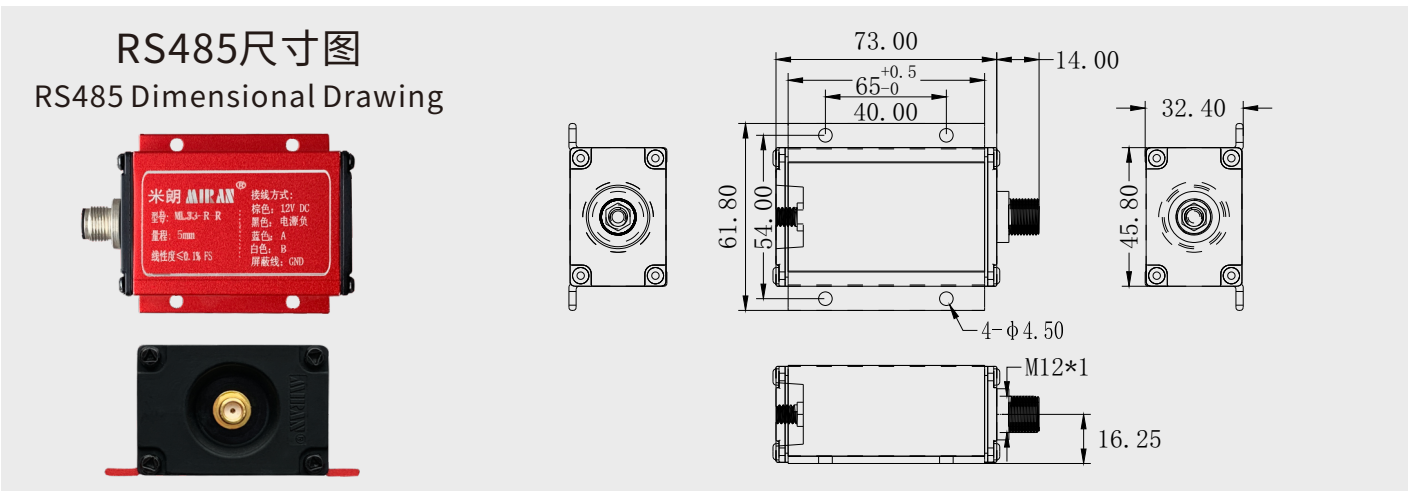
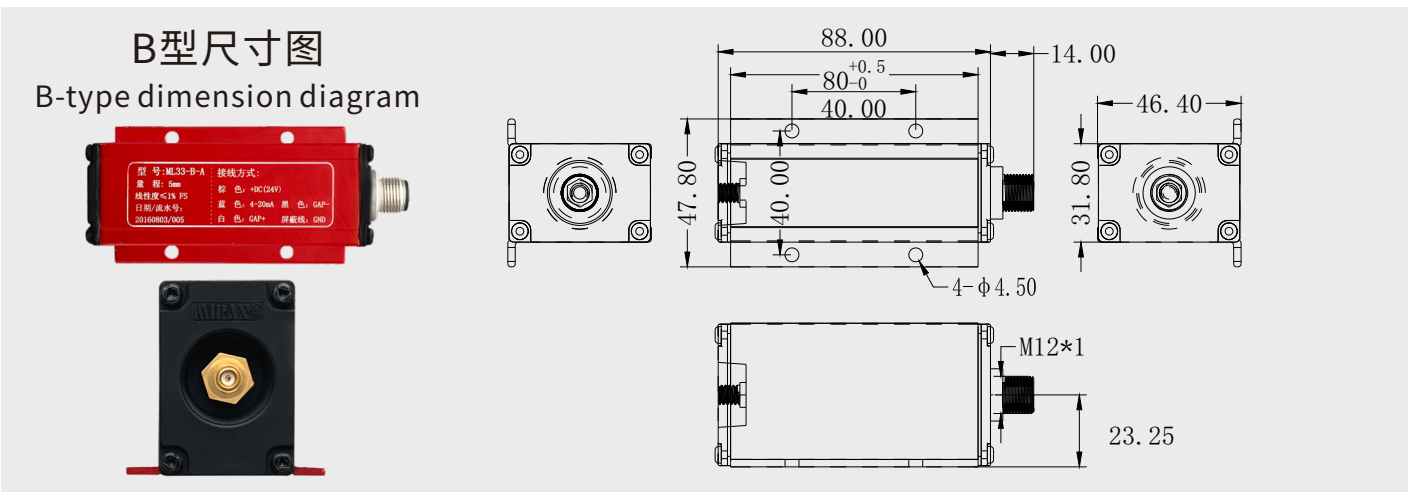
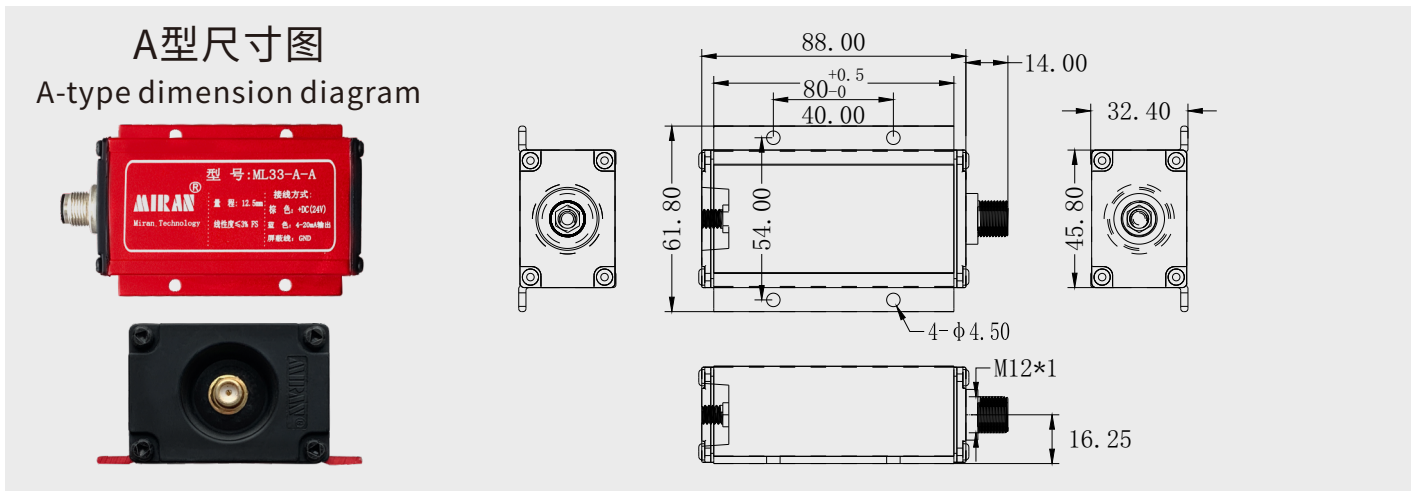

前置器 Proximator

前置器是整个传感器系统的信号处理中心。一方面，前置器为探头线圈提供高频交流激励电流使探头工作；另一方面，前置器通过特殊电路感应出探头头部体与头部体前金属导体的间隙变化，经过前置器的处理，产生随间隙线性变化而变化的电压或电流输出信号。

The preamplifier is the signal processing center of the entire sensor system. On the one hand, the preamplifier provides high-frequency AC excitation current to the probe coil to make the probe work; On the other hand, the preamplifier senses the gap between the probe head and the metal conductor in front of the head through a special circuit. After processing by the preamplifier, it generates a voltage or current output signal that changes linearly with the gap.

产品选型 Product Selection

分体式电涡流探头选型 Selection of split type eddy current probe

ML33 - [A][A] - [B][B] - [C][C] - [D][D]

A探头量程代号选择

Selection of A probe range code

代号 Code	量程 Range	代号 Code	量程 Range
01	1mm	12	12.5mm
02	2mm	20	20mm
04	4mm	25	25mm
05	5mm	50	50mm

B无螺纹长选择

B Unthreaded length selection

探头无螺纹部分是为了方便安装、减少无效的螺纹长度、使拧接螺栓更为快捷

The threaded part of the probe is for easy installation, Reduce ineffective thread length and make bolt tightening faster.

公制螺纹探头

Metric thread probe

0	0	最小无螺纹长 0mm Minimum unthreaded length 0mm
2	5	最大无螺纹长 250mm Maximum unthreaded length 250mm
0	1	递增量 10mm Increase by 10mm

C壳体长度选择

C Shell length selection

探头壳体长度根据现场的使用情况而定，为了保证测量精度、避免探头杆的自身振动带来测量干扰，建议不要使用超过300mm长的壳体长度；当必须使用时，应附加一个增强探头杆强度的安装附件。

The length of the probe housing depends on the on-site usage. In order to ensure measurement accuracy and avoid measurement interference caused by the vibration of the probe rod, it is recommended not to use a housing length exceeding 300mm; When necessary, an additional installation accessory should be added to enhance the strength of the probe rod.

公制壳体长度

Metric thread probe

0	2	最小壳体长度 20mm Minimum shell length 20mm
2	5	最大壳体长度 250mm Maximum shell length 250mm
0	1	递增量 10 mm Increase by 10 mm

D探头外形结构选择

Selection of D-probe external structure

/	默认标准探头结构 Default standard probe structure
C	沉头式探头结构 Countersunk probe structure
F	方形探头结构 Square probe structure
Y	圆形探头结构 Circular probe structure

例如，ML33-05-F表示分体式电涡流量程为5mm，方形式探头结构。

ML33-05-00-03-C表示分体式电涡流量程为5mm，无螺纹长0mm，壳体长度30mm，沉头式探头结构。

注：由于各探头结构不同，所以只有标准式探头/沉头式探头可以选择无螺纹长度与壳体长度，其余探头选型时请省略无螺纹长度与壳体长度选项。

For example, ML33-05-F represents a split type eddy current flow path of 5mm, with a square shaped probe structure. ML33-05-00-03-C represents a split type eddy current flow path of 5mm, an unthreaded length of 0mm, a shell length of 30mm, and a countersunk probe structure.

Note: Due to the different structures of each probe, only standard/countersunk probes can choose between unthreaded length and shell length. Please omit the options for unthreaded length and shell length when selecting other probes.

各种探头可选测量行程（分体式） Various probes can be selected for measuring travel (split type)								
标准式探头 Standard probe	1mm	2mm	4mm	5mm	12.5mm	20mm	25mm	50mm
沉头式探头 Countersunk probe	1mm	2mm	4mm	5mm	/	/	/	/
方形式探头 Square shaped probe	1mm	2mm	4mm	5mm	/	/	/	/
圆形式探头 Circular probe	/	/	/	/	12.5mm	20mm	25mm	50mm

⚡ 分体式电涡流前置器选型 Selection of Split Eddy Current Prox

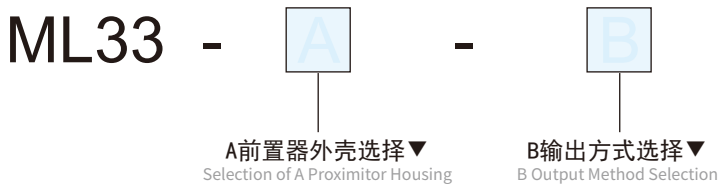

A	A型外壳 A-type housing
B	B型外壳 B-type housing
R	RS485专用 RS485 exclusive

A	表示电流4-20mA输出 Indicating a current output of 4-20mA	+24V DC供电 +24V DC power supply
V1-1	表示电压0-5V输出 Indicates a voltage output of 0-5V	±15V DC供电 ±15V DC power supply
V1-2	表示电压0-5V输出 Indicates a voltage output of 0-5V	9-36V DC供电 9-36V DC power supply
V2-1	表示电压0-10V输出 Indicating voltage 0-10V output	±15V DC供电 ±15V DC power supply
V2-2	表示电压0-10V输出 Indicating voltage 0-10V output	9-36V DC供电 9-36V DC power supply
R	表示RS485输出 Indicates RS485 output	12-24V DC供电 12-24V DC power supply

例:ML33-A-A(表示ML33分体式电涡流前置器，A型外壳，电流4-20mA信号输出，+24V DC供电)

Example: ML33-A-A(represents ML33 split eddy current preprocessor, Type A housing, current 4-20mA signal output, +24V DC power supply)

一体式电涡流位移传感器

Integrated Eddy Current Displacement Sensor

产品实物图 Product Physical Image

一体式电涡流(侧出线) Integrated eddy current (side outlet)



一体式电涡流(直出线) Integrated eddy current (straight out line)

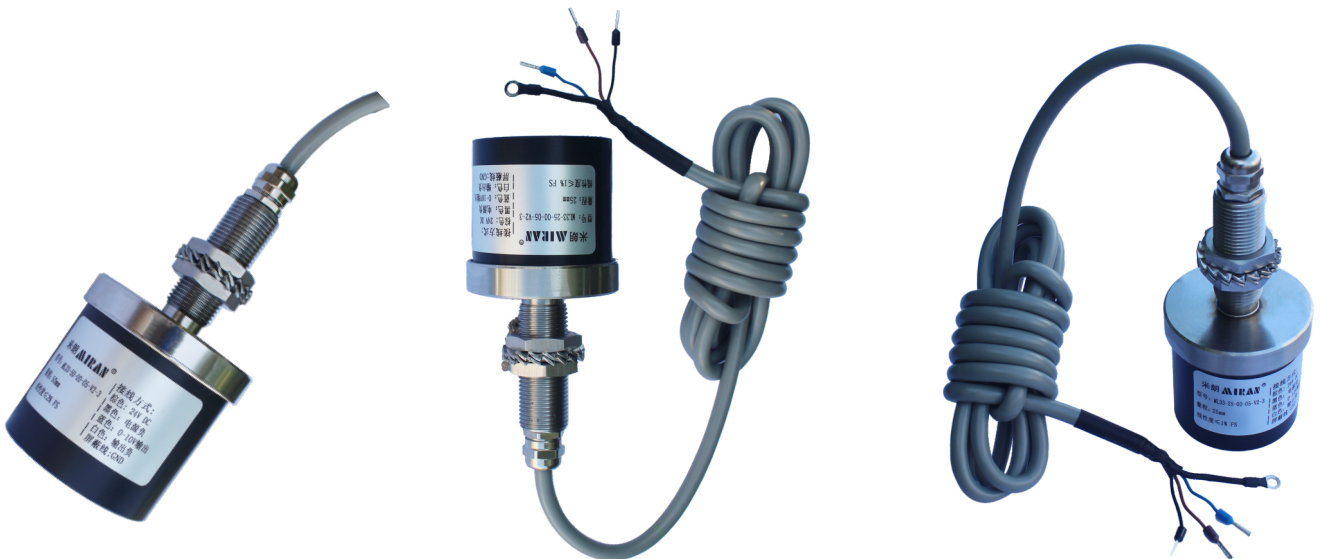

工作原理 Working Principle

电涡流传感器系统的工作原理是电涡流效应，属于一种电感式测量原理。电涡流效应源自振荡电路的能量。而电涡流需要在可导电的材料内才可以形成。给传感器探头内线圈导入一个交变电流，可以在探头线圈周围形成一个磁场。如果将一个导体放入这个磁场，根据法拉第电磁感应定律，导体内会激发出电涡流。根据楞兹定律，电涡流的磁场方向与线圈磁场正好相反，而这将改变探头内线圈的阻抗值。这个阻抗值的变化与线圈到被测物体之间的距离直接相关。

ML33Y一体式电涡流将前置器内置在探头内部，通过测量金属被测体与探头端的相对位置、电涡流位移传感器感应并处理成相应的电信号输出。并以此为依据，计算出对应的距离值，电涡流测量原理可以测量所有导电材料。由于电涡流可以穿透绝缘体，即使表面覆盖有绝缘体的金属材料，也可以作为电涡流传感器的被测物体。独特的圈式绕组设计在实现传感器外形极致紧凑的同时，可以满足其运转于高温测量环境的要求。

The working principle of an eddy current sensor system is the eddy current effect, which belongs to an inductive measurement principle. The eddy current effect originates from the energy of the oscillating circuit. And eddy currents need to be formed within conductive materials. Introducing an alternating current into the coil inside the sensor probe can create a magnetic field around the probe coil. If a conductor is placed in this magnetic field, according to Faraday's law of electromagnetic induction, eddy currents will be excited inside the conductor. According to Lenz's law, the direction of the magnetic field of the eddy current is exactly opposite to the magnetic field of the coil, which will change the impedance value of the coil inside the probe. The change in impedance value is directly related to the distance between the coil and the object being measured.

The ML33Y integrated eddy current sensor integrates a preamplifier inside the probe, and measures the relative position between the metal object being measured and the probe end. The eddy current displacement sensor senses and processes the corresponding electrical signal output. Based on this, calculate the corresponding distance value, and the principle of eddy current measurement can measure all conductive materials. Due to the ability of eddy currents to penetrate insulators, even metal materials covered with insulators can be used as the tested object for eddy current sensors. The unique coil winding design not only achieves an extremely compact appearance of the sensor, but also meets its requirements for operating in high-temperature measurement environments.

技术参数 Technical Parameter

电气指标 Electrical specifications

型号 Model	ML33Y一体式电涡流位移传感器 ML33Y Integrated Eddy Current Displacement Sensor	标定时环境温度 Environmental temperature during calibration	(20±5)°C
测量量程 Measurement range	25mm	测量量程 Measurement range	50mm
探头直径 Probe diameter	50mm	探头直径 Probe diameter	60mm
线性误差(%FS) Linear error(%FS)	≤±1	线性误差(%FS) Linear error(%FS)	≤±2
重复性 Repeatability	2.5μm	重复性 Repeatability	5μm
分辨率 Resolution ratio	2.0μm(0-10V输出), 4.0μm(0-5V输出) 2.0 μM (0-10V output), 4.0 μM (0-5V output)	分辨率 Resolution ratio	2.5μm(0-10V输出), 5.0μm(0-5V输出) 2.5 μM (0-10V output), 5.0 μM (0-5V output)
频率响应 Frequency response	0-1KHZ	输出信号 Output signal	4-20mA, 0~5V, 0~10V, RS485
供电电压 Supply Voltage	+24VDC	工作电流 Working current	<20mA
纹波 Ripple wave	≤20mV	线性中点温漂系数 Linear midpoint temperature drift coefficient	≤0.1%/°C(-20°C~60°C)
静态灵敏度 Static sensitivity	根据输出信号和对应量程而定 Depending on the output signal and corresponding range	电源电缆 Power Cable	默认2m双绞线(长度可定制) Default 2m twisted pair cable (length can be customized)
工作温度 operation temperature	-20°C~+60°C	防护等级 Protection grade	默认IP67(可定制IP68) Default IP67 (customizable IP68)
输出负载 Output Load	电压输出: 负载能力<10KΩ, 电流输出: 负载能力<500Ω Voltage output: load capacity < 10KΩ, current output: load capacity < 500Ω		

产品选型 Product Selection

⚡ 一体式电涡流命名规则 Naming rules for integrated eddy currents

ML33Y

一体式电涡流
Integrated eddy current

A 探头量程代号选择
Selection of A probe range code

▼探头代号分类
Probe code classification

代号	量程
25	25mm
50	50mm

B 无螺纹长选择
B Unthreaded length selection

探头无螺纹部分是为了方便安装、减少无效的螺纹长度、使拧接螺栓更为快捷

The threaded part of the probe is designed to facilitate installation, reduce ineffective thread length, and make bolt tightening more efficient.

▼公制螺纹探头
Metric thread probe

0	0	默认最小无螺纹长 0mm
2	5	最大无螺纹长 250mm
0	1	递增量 10 mm

C 壳体长度选择
C Shell length selection

▼公制壳体长度
Metric shell length

0	5	默认壳体长度 50mm Default shell length 50mm
2	5	最大壳体长度 250mm Maximum shell length 250mm
0	1	递增量 10 mm Increase by 10 mm

探头壳体长度根据现场的使用情况而定，为了保证测量精度、避免探头杆的自身振动带来测量干扰，建议不要使用超过300mm长的壳体长度；当必须使用时，应附加一个增强探头杆强度的安装附件。

The length of the probe housing depends on the usage on site, To ensure measurement accuracy and avoid self vibration of the probe rod Measurement interference caused by movement, it is recommended not to use more than 300mm Long shell length; When necessary, an additional one should be added Installation accessories to enhance the strength of the probe rod.

D 输出信号选择
D Output signal selection

V1	电压0-5V输出 Voltage 0-5V output
V2	电压0-10V输出 Voltage 0-10V output
R	RS485输出 RS485 output

E 出线方式选择
Selection of E outgoing line method

DL	直出线 Straight out line
SL	侧出线 Side outgoing line

例如，ML33Y-25-V1-SL表示一体式电涡流量程为25mm，电压0-5V输出，出线方式为侧出线。

ML33Y-25-00-05-V1-DL表示一体式电涡流量程为25mm，无螺纹长0mm，壳体长度50mm，电压0-5V输出，出线方式为直出线。

注：由于各探头结构不同，选型时若出线方式为直出线才选择无螺纹长度与壳体长度，若出线方式为侧出线请省略无螺纹长度与壳体长度选项。

For example, ML33Y-25-V1-SL represents an integrated eddy current flow path of 25mm, Voltage 0-5V output and a side outlet method.

ML33Y-25-00-05-V1-DL represents an integrated eddy current flow path of 25mm, with an unthreaded length of 0mm and a shell length of 50mm. Voltage 0-5V output, and the output method is direct.

Note: Due to the different structures of each probe, the unthreaded length and shell length can only be

selected if the outlet method is straight. If the outlet method is side outlet, please omit the unthreaded length Option for shell length.

安装尺寸图 Drawing

一体式电涡流(侧出线) Integrated eddy current (side outlet)

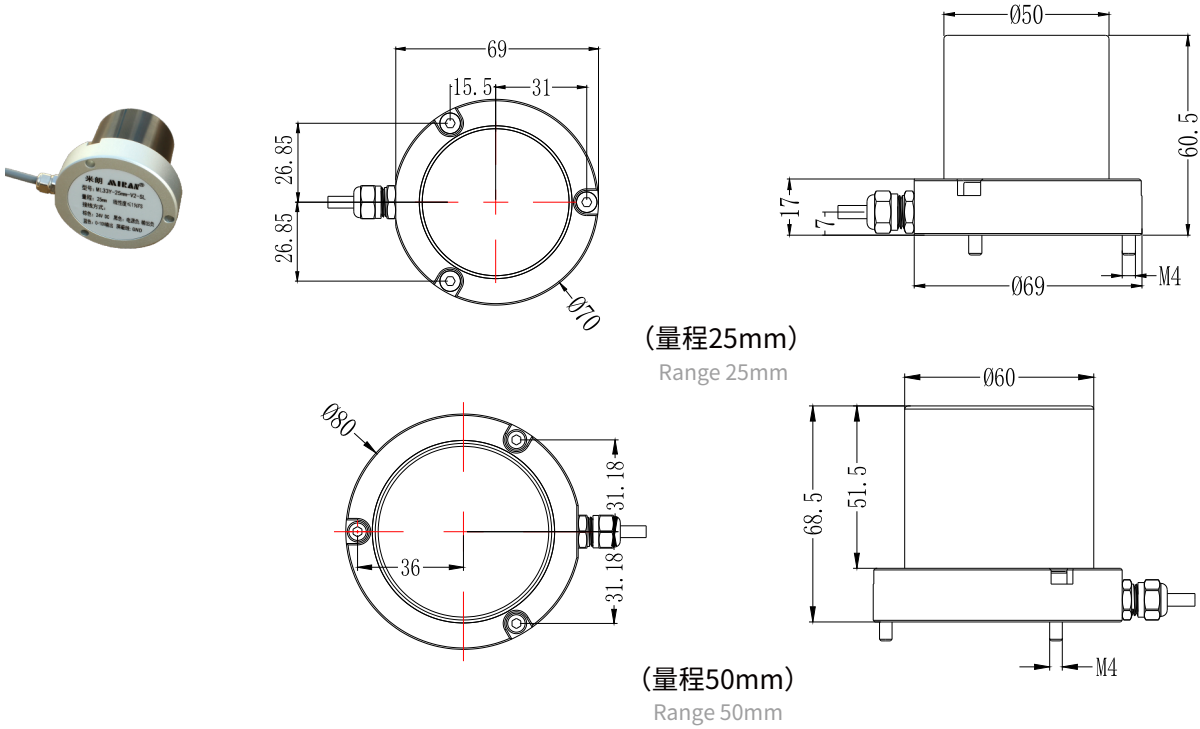

一体式电涡流(直出线) Integrated eddy current (straight out line)

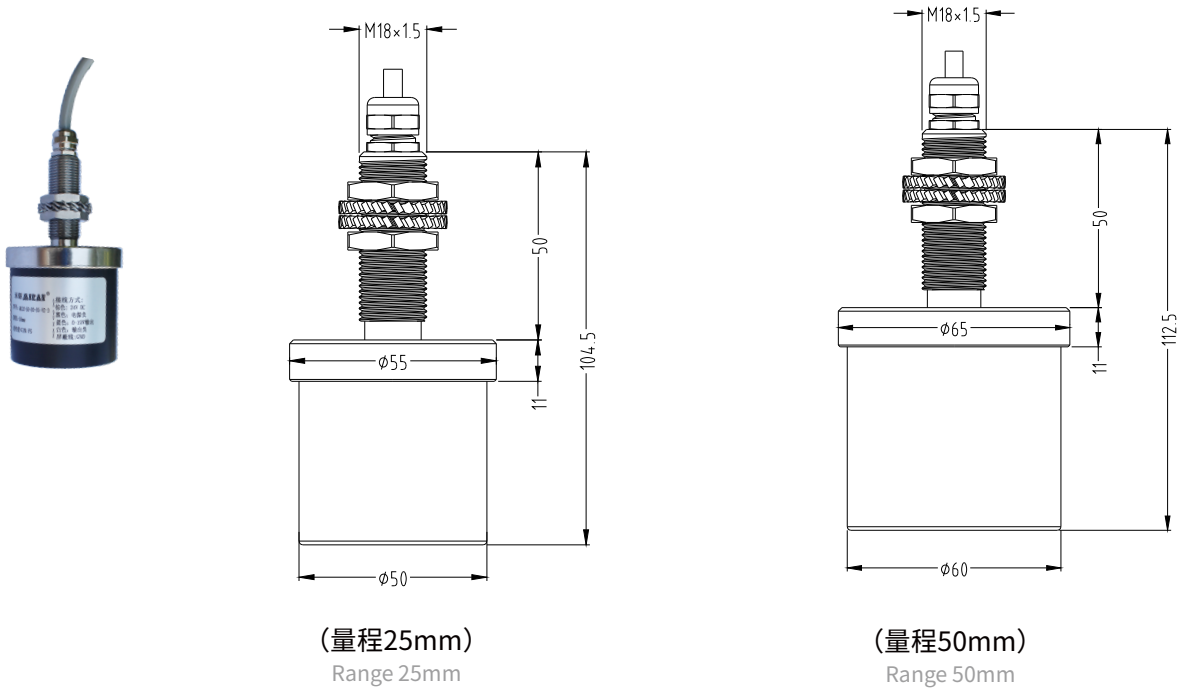

量程 Range	探头直径 Probe diameter	探头长度 Probe length	壳体长度 Shell length	螺纹规格 Thread specification
25mm	φ50mm	43.5mm	50mm	M18*1.5
50mm	φ60mm	51.5mm	50mm	M18*1.5

非标专区（电涡流位移传感器）

Non Standard Zone (Eddy Current Displacement Sensor)

MDW-01电涡流传感器 MDW-01 eddy current sensor

产品实物图 Product Physical Image



安装尺寸图 Drawing

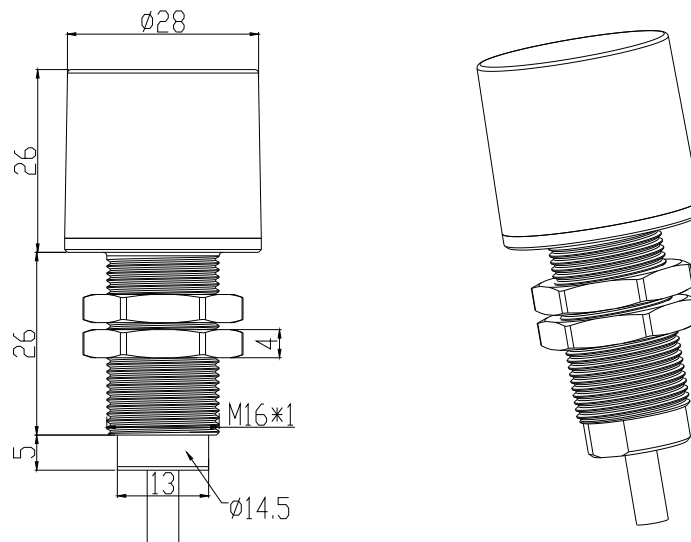

工作原理 Working Principle

MDW-01电涡流传感器通过测量金属被测体与探头端的相对位置、电涡流传感器感应并处理成相应的电信号输出。

The MDW-01 eddy current sensor measures the relative position between the metal object being measured and the probe end, and the eddy current sensor senses and processes the corresponding electrical signal output.

技术参数 Technical Parameter

测量量程 Measurement range	10mm	探头直径 Probe diameter	28mm
供电电压 Supply Voltage	+12~24VDC	输出信号 Output signal	1~5V
线性误差 Linearity error	±2%FS	分辨率 Resolution ratio	0.2%FS
频率响应 Frequency response	100Hz	工作电流 Working current	<20mA
保护等级 Protection level	默认IP65 Default Ip65	电源电缆 Power Cable	默认1m线长 Default 1m line length
线性中点温漂系数 Linear midpoint temperature drift coefficient	≤0.1%/°C(-20°C~60°C)		
输出负载 Output Load	负载能力10KΩ以上 Load capacity above 10KΩ		
标定时环境温度 Environmental temperature during calibration	(20±5)°C		
工作温度 Operation temperature	-20°C~+60°C		
接线定义 Wiring Definition	<p>● 棕色：电源正极 Brown: positive pole of power supply</p> <p>● 黑色：电源负极 Black: Negative pole of power supply</p> <p>● 蓝色：电压输出 Blue: Voltage output</p>		

集成式电涡流传感器 Integrated eddy current sensor

产品实物图 Product Physical Image

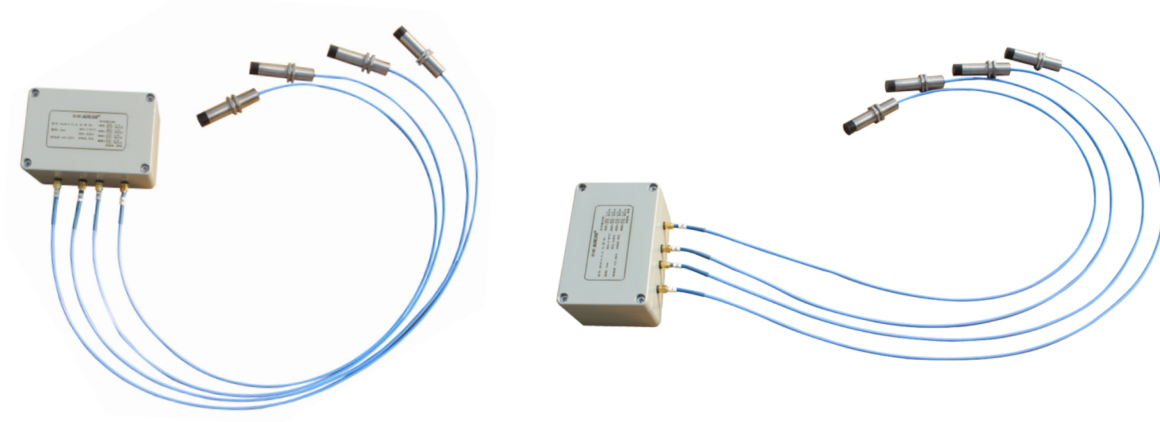

安装尺寸图 Drawing

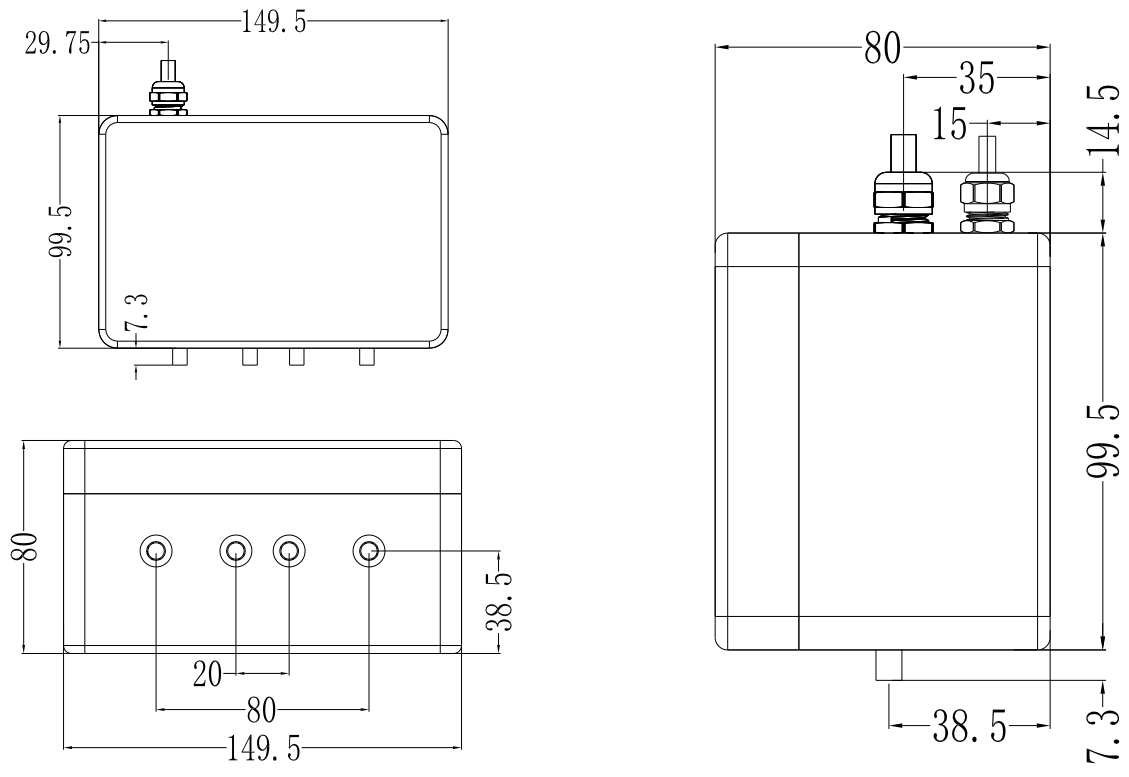

客户如有特殊定制要求均可联系我司工作人员洽谈，可根据客户需求特殊定制。

If customers have special customization requirements can contact our staff to negotiate, can be customized according to customer needs.

电涡流传感器安装使用

Installation And Use Of Eddy Current sensors

探头的安装 Installation Of Probes

安装探头时，您应注意以下几个问题:

When installing the probe, you should pay attention to the following issues:

- 各探头间的距离
The distance between each probe
- 探头安装间隙
Probe installation gap
- 安装支架的选择
Selection of installation brackets
- 探头的高压环境
The high-pressure environment of the probe
- 探头的抗腐蚀性
Corrosion resistance of the probe
- 探头与安装面的距离
Distance between probe and mounting surface
- 探头所带电缆的安装
Installation of cables carried by the probe
- 电缆转接头的密封与绝缘
Sealing and insulation of cable adapters

各探头间的距离

The distance between each probe

当探头头部线圈中通过电流时，在头部周围会产生交变磁场，因此在安装时要注意两个探头的安装距离不能太近，否则两探头之间会通过磁场互相干扰(如下图各探头间的距离所示)，在输出信号上迭加两探头的差频信号，造成测量结果的失真，这种情况我们称之为相邻干扰。排除相邻干扰有关的因素:被测体的形状，探头的头部直径以及安装方式。通常情况下探头之间的最小距离见下表。

When a current passes through the coil at the head of the probe, an alternating magnetic field is generated around the head. Therefore, when installing, it is important to note that the installation distance between the two probes should not be too close, otherwise the two probes will interfere with each other through the magnetic field (as shown in the distance between the probes in the figure below). The difference frequency signal of the two probes is superimposed on the output signal, causing distortion of the measurement results. This situation is called adjacent interference. Excluding factors related to adjacent interference: the shape of the tested object, the diameter of the probe head, and the installation method. The minimum distance between probes is usually shown in the table below.

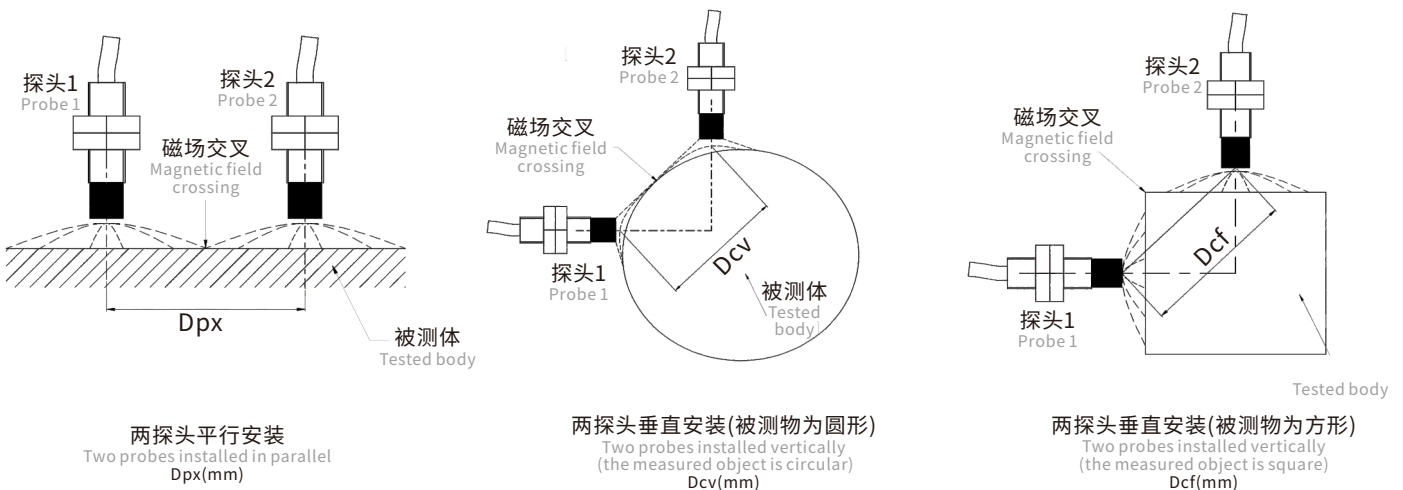

🔗 探头安装距离 Probe mounting distance

探头直径(mm) Probe diameter (mm)	两探头平行安装 Two probes installed in parallel Dpx(mm)	两探头垂直安装(被测物为圆形) Two probes installed vertically (the measured object is circular) Dcv(mm)	两探头垂直安装(被测物为方形) Two probes installed vertically (the measured object is square) Dcf(mm)
φ6mm	40.6mm	35.6mm	22.9mm
φ8mm	40.6mm	35.6mm	22.9mm
φ11mm	80mm	70mm	40mm
φ17mm	100mm	80mm	50mm
φ30mm	160mm	130mm	90mm
φ40mm	180mm	160mm	100mm
φ50mm	200mm	180mm	150mm
φ60mm	300mm	200mm	180mm

探头头部与安装面的距离 Distance between probe head and mounting surface

探头头部发射的交变磁场在径向和横向上都有一定的扩散。因此在安装时，就必须考虑着安装面金属导体材料的影响，应保证探头的头部与安装面之间不小于一定的距离，工程塑料头部体要完全露出安装面(图一)，否则应将安装面加工成平底孔(图二)或倒角(图三)，如下图所示。

The alternating magnetic field emitted by the probe head has a certain diffusion in both radial and transverse directions. Therefore, in the installation, it is necessary to consider the influence of the metal conductor material on the installation surface, should ensure that the head of the probe and the installation surface is not less than a certain distance, the engineering plastic head body should be completely exposed to the installation surface (Figure 1), otherwise the installation surface should be processed into a flat bottom hole (Figure 2) or chamfer (Figure 3), as shown in the following figure.

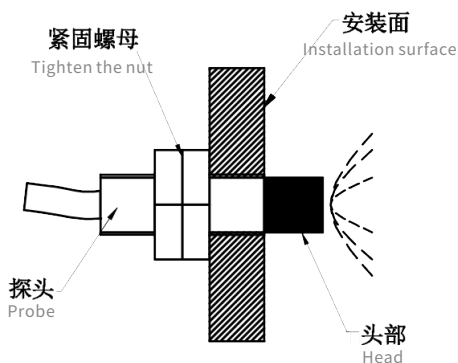

图一
Figure 1

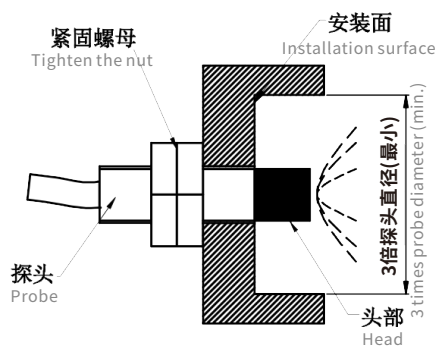

图二
Figure 2

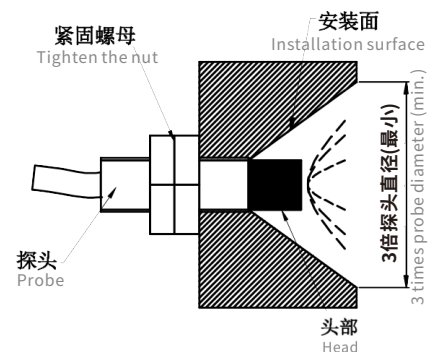

图三
Figure 3

🔧 探头安装步骤 Probe installation steps

1、根据测量部位的量程、安装空间的环境和尺寸、被测体材料等特性选定传感器，并检查传感器的各部分外观是否完好、各部分是否配套（如探头直径与前置器型号中规定的配套探头直径是否一致、探头电缆长度是否符合前置器对电缆长度的要求等）。通常成套订购的传感器，在出厂时提供有数据校验单，校验单上注明了配套校准的传感器各部分的型号、编号，用户可据此与产品上的标记核对。然后在传感器的探头、前置器上分别进行特定标记。

1. Select the sensor based on the measurement range of the measuring location, the environment and size of the installation space, and the characteristics of the measured body material. Check whether the appearance of each part of the sensor is intact and whether each part is matched (such as whether the probe diameter is consistent with the matching probe diameter specified in the front end model, whether the probe cable length meets the requirements of the front end for cable length, etc.). Usually, sensors ordered in sets are provided with a data verification sheet at the factory, which indicates the model and number of each part of the calibrated sensor. Users can use this sheet to verify with the markings on the product. Then, specific markings are placed on the probe and preamplifier of the sensor.

2、探头的电缆接头是和内部电路相接的，而且不具备密封性。为了避免接头和机壳接触以及加强密封性，应该采用热缩套管加热收缩包紧接头。这样还能起到防止接头松动的作用。不要用粘性的电工胶带来绝缘接头，因为油雾会溶解胶带上的粘性物而污染接头。

2. The cable connector of the probe is connected to the internal circuit and does not have sealing properties. To avoid contact between the joint and the casing and enhance sealing, heat shrink tubing should be used to heat shrink and wrap the joint tightly. This can also prevent the joint from loosening. Do not use sticky electrical tape to insulate the joint, as oil mist can dissolve the adhesive on the tape and contaminate the joint.

3、探头电缆长度一经选定，在使用时不能随意缩短或加长，过长的电缆不能随意剪断，否则可能造成传感器严重超差或不能正常工作。探头电缆长度应该与前置器要求的电缆长度一致。除非特殊规格。

3. Once the length of the probe cable is selected, it should not be arbitrarily shortened or lengthened during use. Long cables should not be cut arbitrarily, otherwise it may cause the sensor to seriously exceed the tolerance or malfunction. The length of the probe cable should be consistent with the required cable length for the preamplifier. Unless otherwise specified.

4、将传感器各部分连接好，通电检查传感器，若超差，则需进行重新校准。检查时应特别注意校准试件材料是否与被测体材料一致或具有相近成分。

4. Connect all parts of the sensor, power on and inspect the sensor. If it exceeds the tolerance, recalibration is necessary. During the inspection, special attention should be paid to whether the calibration specimen material is consistent with or has similar composition to the tested material.

5、如果未订购配套的安装支架，则应自行加工合适的安装支架。外部安装探头支架比较复杂，一般应订购。

5. If a matching installation bracket has not been ordered, suitable installation brackets should be processed by oneself. The external installation of probe brackets is quite complex and should generally be ordered.

6、在机座上加工支撑安装支架的螺孔，内部安装探头的支架一般都需要两个螺孔进行紧固，外部安装探头的一般都是在机壳上加工带螺纹的通孔。

6. On the machine base, screw holes are machined to support the installation bracket. The bracket for installing the probe internally usually requires two screw holes for fastening, while the bracket for installing the probe externally usually has threaded through holes machined on the machine casing.

7、紧固安装探头支架。如果是外部安装探头，则应先将探头紧固在支架上，再将支架拧进安装孔内。

7. Tighten the installation probe bracket. If the probe is installed externally, the probe should be fastened to the bracket first, and then the bracket should be screwed into the installation hole.

8、调整探头安装间隙。不同的用途，探头的初始安装间隙有不同的要求。

8. Adjust the installation gap of the probe. The initial installation clearance of the probe varies for different purposes.

9、紧固安装探头。对于内部安装探头，如果是采用角钢支架则用两个螺母背紧，采用夹块则用紧固螺钉锁紧；对于外部安装探头，则紧固外部安装支架。紧固螺钉、螺母都应加弹簧垫圈以防松动。

9. Tighten the installation probe. For internal installation of probes, if an angle steel bracket is used, two nuts are used to tighten it, and if a clamp block is used, fastening screws are used to lock it; For externally installed probes, tighten the external mounting bracket. Spring washers should be added to tighten screws and nuts to prevent loosening.

⚡ 前置器的安装 Installation of Proximator

变送器对工作环境的要求比探头严格得多，通常将它安装在远离危险区，其周围环境应该无腐蚀性气体，干燥、震动小，环境温度与室温相差不大。在机器旁安装，为了保证变送器工作安全可靠，有必要采用专用安装盒。为了防止不同地电位造成的干扰，必须采用单点接地。

The requirements for the working environment of a transmitter are much stricter than those of a probe. It is usually installed away from hazardous areas, and the surrounding environment should be free of corrosive gases, dry, and with minimal vibration. The ambient temperature should not differ significantly from room temperature. To ensure the safe and reliable operation of the transmitter when installed next to the machine, it is necessary to use a dedicated installation box. To prevent interference caused by different ground potentials, a single point grounding must be used.

⚡ 对探头安装间隙的要求 Requirements for probe installation clearance

安装探头时，应考虑传感器的线性测量范围和被测间隙的变化量，当被测间隙总的变化量与传感器的线性工作范围接近时，尤其要注意（在订货选型时应使所选的传感器线性范围大于被测间隙的15%以上）。通常，测量振动时，将探头的安装间隙设在传感器的线性中点；测量位移时，要根据位移往哪个方向变化或往哪个方向的变化量较大来决定其安装间隙的设定。当位移向远离探头端部的方向变化时，安装间隙应设定在线性近端；反之，则应设定在线性远端。

When installing the probe, the linear measurement range of the sensor and the variation of the measured gap should be considered. When the total variation of the measured gap is close to the linear working range of the sensor, special attention should be paid (when ordering and selecting, the linear range of the selected sensor should be greater than 15% of the measured gap). Usually, when measuring vibration, the installation gap of the probe is set at the linear midpoint of the sensor; When measuring displacement, the setting of installation clearance should be determined based on which direction the displacement changes or which direction the change is significant. When the displacement changes in the direction away from the end of the probe, the installation gap should be set at the linear near end; On the contrary, it should be set at the linear far end.

调整探头安装间隙可以采用下列方法

The following methods can be used to adjust the installation gap of the probe

连接好探头、延伸电缆、前置器，接通传感器系统电源，用万用表监测前置器的输出，同时调节探头与被测面的安装间隙（即出厂检测报告中的非线性区域），当前置器的输出等于安装间隙所对应的电压或电流时（该值可由出厂检测报告中查得），再拧紧探头所带的两个紧固螺母即可。

通过测量前置器输出电压来确定安装间隙，有可能会产生一种假象：当探头头部还未露出安装孔时，由于安装孔周围的金属影响，可能使得前置器的输出等于安装间隙所对应的电压或电流输出值。探头调整到正确的安装位置，前置器的输出应该是：首先是较大的饱和输出（此时探头还未放进安装孔中），然后是较小的输出（此时探头放进安装孔内），继续将探头塞进安装孔，前置器的输出会变为最大的输出（此时探头头部露出安装孔，但与被测面的间隙较大），再继续塞进探头，前置器的输出等于安装间隙所对应的值，此时探头才是正确的安装间隙。

Connect the probe, extension cable, preprocessor, switch on the sensor system power supply, use a multimeter to monitor the output of the preprocessor, and adjust the installation gap between the probe and the measured surface (that is, the non-linear area in the factory test report), when the output of the preprocessor is equal to the corresponding voltage or current of the installation gap (the value can be checked by the factory test report), Then tighten the two fastening nuts with the probe.

By measuring the output voltage of the preamplifier to determine the installation gap, it is possible to create an illusion: when the probe head has not yet exposed the installation hole, due to the influence of the metal around the installation hole, the output of the preamplifier may be equal to the voltage or current output value corresponding to the installation gap. Adjust the probe to the correct installation position, and the output of the preamplifier should be: first, a larger saturated output (at this time, the probe has not yet been placed in the installation hole), then a smaller output (at this time, the probe is placed in the installation hole), continue to insert the probe into the installation hole, and the output of the preamplifier will become the maximum output (at this time, the probe head is exposed in the installation hole, but the gap with the measured surface is large), and then continue to insert the probe. The output of the preamplifier is equal to the value corresponding to the installation gap, and the probe is the correct installation gap.

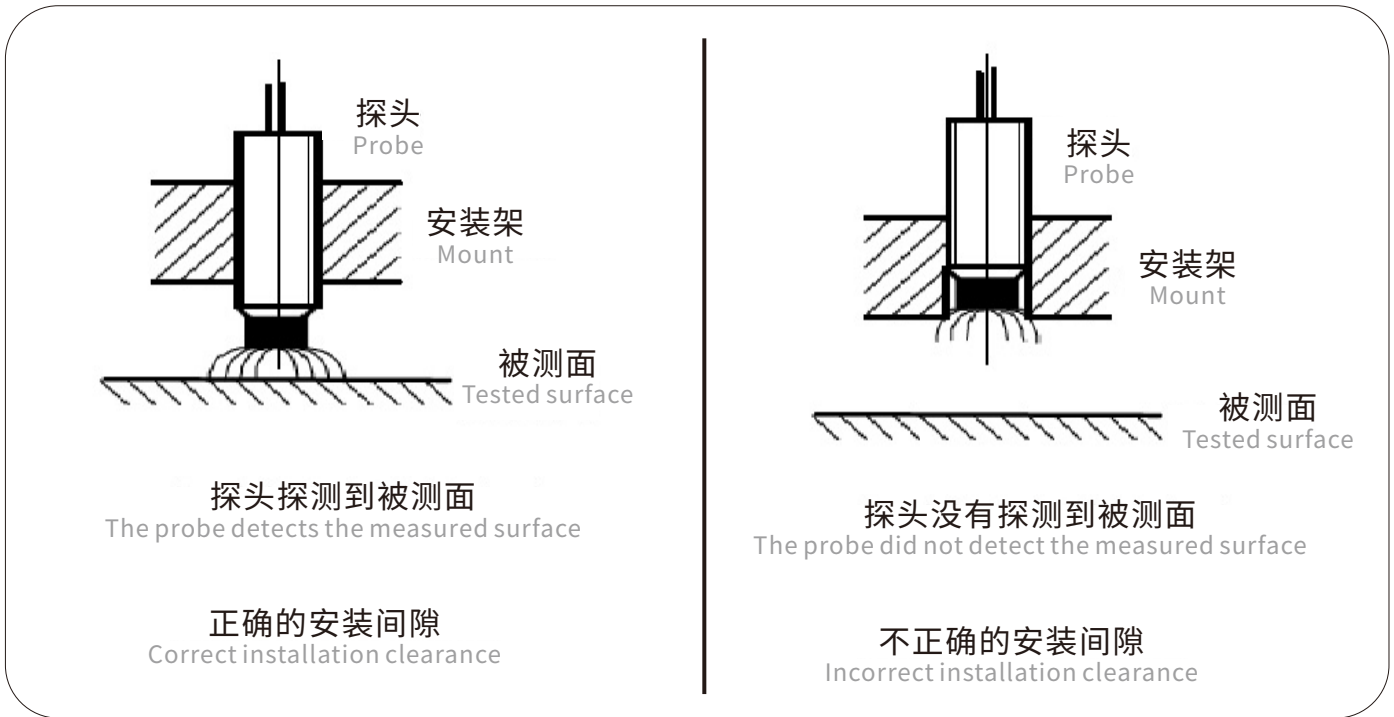

安装注意事项 Installation Precautions

⚡ 对初始间隙的要求 Requirements for initial clearance

各种型号电涡流传感器，都是在一定的间隙电压值下它的读数才有较好的线性度，所以在安装传感器时必须调整好合适的初始间隙，对每一套产品都会进行特性试验，绘出相应的特性曲线，工程技术人员在使用传感器的时候必须仔细研究配套的校验证书，认真分析特性曲线，以确定传感器是否满足所要测量的间隙，一般传感器直径越大所测量间隙也越大。所以，这个间隙参数没有固定值，和很多因素都有关系，出厂时候会根据客户不同的测量材质等情况，实际测试后标明，间隙参数详见出厂检测报告。

Various models of eddy current sensors have good linearity in their readings only at a certain gap voltage value. Therefore, when installing the sensor, it is necessary to adjust the appropriate initial gap, conduct characteristic tests on each set of products, and draw corresponding characteristic curves. When using the sensor, engineering and technical personnel must carefully study the matching calibration certificate and analyze the characteristic curve to determine whether the sensor meets the measured gap. Generally, the larger the sensor diameter, the larger the measured gap. So, this gap parameter has no fixed value and is related to many factors. When leaving the factory, it will be indicated after actual testing based on the customer's different measurement materials and other conditions. See the factory test report for clearance parameters.

⚡ 对探头支架的要求 Requirements for probe brackets

电涡流传感器安装在固定支架上，因此支架的好坏直接决定测量的效果，这就要求支架应有足够的刚度以提高自振频率，避免或减小被测体振动时支架也同时受激自振，支架的自振频率至少应为机械旋转速度的10倍，支架应与被测表面切线方向平行，传感器垂直安装在支架上，虽然探头的中心线在垂直方向偏15°角时对系统特性没有影响，但最好还是保证传感器与被测面垂直。

The eddy current sensor is installed on a fixed bracket, so the quality of the bracket directly determines the measurement effect. This requires the bracket to have sufficient stiffness to increase the natural vibration frequency, avoid or reduce the excitation of the bracket during the vibration of the measured body. The natural vibration frequency of the bracket should be at least 10 times the mechanical rotation speed. The bracket should be parallel to the tangent direction of the measured surface, and the sensor should be installed vertically on the bracket. Although the center line of the probe deviates by 15° in the vertical direction and has no effect on the system characteristics, it is best to ensure that the sensor is perpendicular to the measured surface.

⚡ 被测体材料对传感器测量结果的影响

The influence of the material of the tested object on the measurement results of the sensor

传感器特性与被测体的电导率磁导率有关，当被测体为导磁材料(如普通钢、结构钢等)时，由于涡流效应和磁效应同时存在，且磁效应反作用于涡流效应，使得涡流效应减弱，即传感器的灵敏度降低。而当被测体为弱导磁材料(如铜、铝、合金钢等)时，由于磁效应弱，相对来说涡流效应要强，因此传感器感应灵敏度要高。

The characteristics of the sensor are related to the conductivity and magnetic permeability of the measured body. When the measured body is made of magnetic conductive materials (such as ordinary steel, structural steel, etc.), the eddy current effect and magnetic effect coexist, and the magnetic effect acts on the eddy current effect, weakening the eddy current effect and reducing the sensitivity of the sensor. When the tested object is made of weakly magnetic materials (such as copper, aluminum, alloy steel, etc.), due to the weak magnetic effect, the eddy current effect is relatively stronger, so the sensor sensitivity is higher.

铜 Copper	14.9V/mm	45号钢 45 # steel	8.2V/mm
铝 Aluminium	14.0V/mm	40CrMo钢 40CrMo steel	8.0V/mm
不锈钢 (1Cr18Ni9Ti) Stainless steel (1Cr18Ni9Ti)	10.4V/mm		

⚡ 被测体表面加工状况对传感器测量结果的影响

The influence of the surface processing condition of the measured object on the measurement results of the sensor

被测体正对探头的表面光洁度也会影响测量结果！不光滑的被测体表面，在实际的测量应用中会带来较大的附加误差，特别是对于振动测量，误差信号与实际的振动信号叠加一起，并且在电气上很难分离，因此被测表面应该光洁，不应存在刻痕、洞眼、凸台、凹槽等缺陷（对于特意为键相器、转速测量设置的凸台或凹槽除外）。一般对于振动测量的被测表面粗糙度要求在0.4um~0.8um之间；对于位移测量被测表面粗糙度要求在0.4um~1.6um之间。如果不能满足，需要对被测面进行研磨或抛光。

The surface smoothness of the measured object facing the probe can also affect the measurement results! The unsmooth surface of the measured object can bring significant additional errors in practical measurement applications, especially for vibration measurement. The error signal is superimposed with the actual vibration signal and is difficult to separate electrically. Therefore, the measured surface should be smooth and free of defects such as scratches, holes, protrusions, grooves, etc. (except for protrusions or grooves specifically designed for keyphasors and speed measurement). Generally, the required surface roughness for vibration measurement is between 0.4um and 0.8um; The required surface roughness for displacement measurement should be between 0.4um and 1.6um. If it cannot be met, it is necessary to grind or polish the measured surface.

⚡ 被测体表面残磁效应对传感器的影响

The influence of residual magnetic effect on the surface of the measured object on the sensor

电涡流效应主要集中在被测体表面，如果由于加工过程中形成残磁效应，以及淬火不均匀、硬度不均匀、金相组织不均匀、结晶结构不均匀等都会影响传感器特性。在进行振动测量时，如果被测体表面残磁效应过大，会出现测量波形发生畸变。

The eddy current effect mainly concentrates on the surface of the measured object. If residual magnetic effects are formed during the processing, as well as uneven quenching, hardness, metallographic structure, and crystalline structure, it will affect the characteristics of the sensor. When conducting vibration measurements, if the residual magnetic effect on the surface of the measured object is too large, distortion of the measurement waveform may occur.

⚡ 被测体表面镀层对传感器的影响

The effect of surface coating on the sensor of the tested object

被测体表面的镀层对传感器的影响相当于改变了被测体材料，视其镀层的材质、厚薄，传感器的灵敏度会略有变化。

The effect of the coating on the surface of the measured body on the sensor is equivalent to changing the material of the measured body. Depending on the material and thickness of the coating, the sensitivity of the sensor will slightly change.

⚡ 被测体表面尺寸对传感器的影响

The influence of surface size of the measured object on the sensor

由于探头线圈产生的磁场范围是一定的，而被测体表面形成的涡流场也是一定的。这样就对被测体表面大小有一定要求。为了防止电涡流产生的磁场影响仪器的正常输出安装时传感器头部四周必须留有一定范围的非导电介质空间，如果在某一部位要同时安装两个以上的传感器，就必须考虑是否会产生交叉干扰，两个探头之间一定要保持规定的距离。

通常，当被测体表面为平面时，以正对探头中心线的点为中心，被测面直径应大于探头头部直径的1.5倍以上；当被测体为圆轴且探头中心线与轴心线正交时，一般要求被测轴直径为探头头部直径的3倍以上，否则传感器的灵敏度会下降，被测体表面越小，灵敏度下降越多。当被测体表面大小与探头头部直径相同，其灵敏度会下降到72%左右。被测体的厚度也会影响测量结果。被测体中电涡流场作用的深度由频率、材料导电率、导磁率决定。因此如果被测体太薄，将会造成电涡流作用不够，使传感器灵敏度下降，一般要求厚度大于0.1mm以上的钢等导磁材料及厚度大于0.05mm以上的铜、铝等弱导磁材料，则灵敏度不会受其厚度的影响。

Due to the limited range of magnetic field generated by the probe coil, as well as the eddy current field formed on the surface of the measured object. This places certain requirements on the surface size of the tested object. In order to prevent the magnetic field generated by eddy currents from affecting the normal output of the instrument, a certain range of non-conductive medium space must be left around the sensor head during installation. If two or more sensors need to be installed at the same time in a certain location, it is necessary to consider whether cross interference will occur, and the specified distance must be maintained between the two probes. Usually, when the surface of the measured object is flat, the diameter of the measured surface should be greater than 1.5 times the diameter of the probe head, with the point facing the centerline of the probe as the center; When the measured body is a circular axis and the centerline of the probe is orthogonal to the axis, it is generally required that the diameter of the measured axis is more than three times the diameter of the probe head. Otherwise, the sensitivity of the sensor will decrease. The smaller the surface of the measured body, the more sensitivity will decrease. When the surface size of the tested object is the same as the diameter of the probe head, its sensitivity will decrease to about 72%. The thickness of the measured body can also affect the measurement results. The depth of the eddy current field in the measured body is determined by frequency, material conductivity, and permeability. Therefore, if the measured body is too thin, it will cause insufficient eddy current effect, leading to a decrease in sensor sensitivity. Generally, it is required to use magnetic materials such as steel with a thickness greater than 0.1mm and weak magnetic materials such as copper and aluminum with a thickness greater than 0.05mm, so the sensitivity will not be affected by their thickness.

⚡ 高频同轴电缆对传感器的影响

The influence of high-frequency coaxial cables on sensors

高频同轴电缆也是影响电涡流传感器电气性能的一个主要原因。由于传感器工作在高频状态(振荡频率约1MHZ左右)，所以高频同轴电缆的频率衰减、温度特性、阻抗、长度等都成为影响传感器性能的因素！

High frequency coaxial cables are also a major factor affecting the electrical performance of eddy current sensors. Due to the sensor operating in a high-frequency state (oscillation frequency of about 1MHz), the frequency attenuation, temperature characteristics, impedance, length, and other factors of high-frequency coaxial cables have become factors that affect sensor performance!

⚡ 外界磁场对传感器的影响

The influence of external magnetic field on sensors

电涡流传感器属于电感式传感器，由于其主要作用原理就是电涡流效应，所以，对于外界磁场的影响在工程应用中应该充分考虑！强的外界磁场肯定会影响传感器的性能。

对于外界静磁场，由于静磁场强度是一定的，方向与涡流磁场可能呈现各种状况，而一旦外界静磁场方向确定，其对涡流磁场的干扰也是一定的了。所以在实际的工程应用中，静磁场的影响可以通过现场的试验测量出传感器灵敏度的变化，通过后续电路或软件算法排除。

对于外界交变磁场，例如大型励磁机、频繁启动的大型电机、启动机等，其磁场方向和强度都可能不是一个确定的值，因而产生的交变磁场对涡流磁场的影响也是交变的。所以，在工程应用中应该尽量使电涡流传感器远离交变磁场的作用范围，或采取磁场屏蔽措施使产生的影响最小。

Eddy current sensors belong to inductive sensors, and their main working principle is the eddy current effect. Therefore, the influence of external magnetic fields should be fully considered in engineering applications! A strong external magnetic field will definitely affect the performance of the sensor. For the external static magnetic field, due to the constant strength of the static magnetic field, the direction and eddy current magnetic field may exhibit various conditions. Once the direction of the external static magnetic field is determined, its interference with the eddy current magnetic field is also certain. So in practical engineering applications, the influence of static magnetic fields can be measured through on-site experiments to determine changes in sensor sensitivity, which can be eliminated through subsequent circuits or software algorithms. For external alternating magnetic fields, such as large exciters, frequently started large motors, starters, etc., the direction and intensity of the magnetic field may not be a fixed value, so the impact of the generated alternating magnetic field on the eddy current magnetic field is also alternating. Therefore, in engineering applications, eddy current sensors should be kept as far away from the range of alternating magnetic fields as possible, or magnetic field shielding measures should be taken to minimize the impact.

湖北米朗科技股份有限公司 电涡流检测报告

一、检测对象

产品名称	前置器型号	探头型号	量程	供电	被测物尺寸
电压型	ML33-A-V1-2	ML33-12-00-04	12.5MM	DC9-36V	≥ 90*90 (mm)

二、检测工具

五位半数字万用表，直流稳压电源，滚珠螺杆与线性滑轨模组平台及光栅尺数显装置。

三、检测数据

温度：25 °C ± 5 °C 供电：12 ± 0.01 VDC 编号：0275 日期：2023/3/9
 试件材料：45#钢 线性范围：2.3mm-14.8mm 线性中点：8.55mm 中点输出值：2.492 V

位移间距 (mm)	输出 (V)
0.000	0.000
1.250	0.496
2.500	0.987
3.750	1.482
5.000	1.987
6.250	2.492
7.500	3.003
8.750	3.513
10.000	4.019
11.250	4.523
12.500	5.022

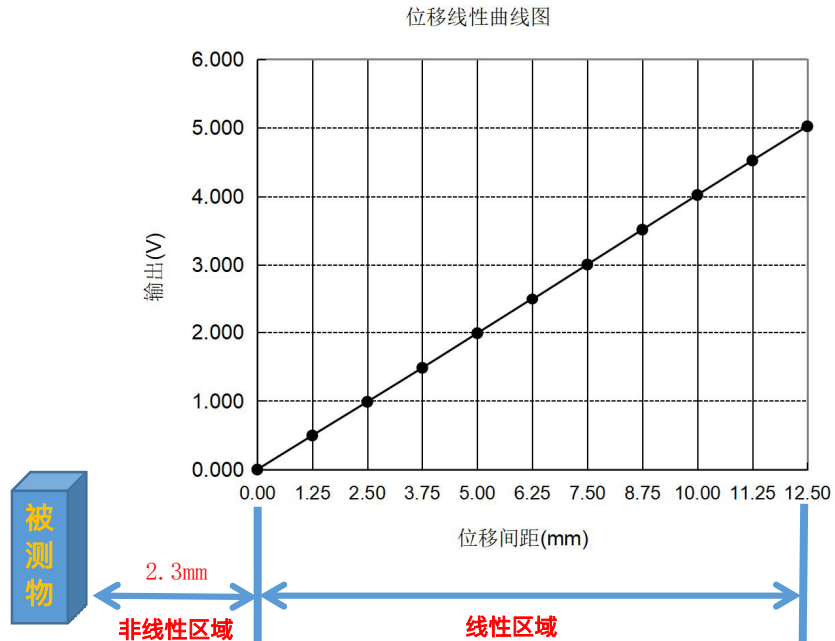

测试结果：独立线性率 0.22% FS

经检验该产品达到标准，准许出厂

检验员：毛礼艳

审核：周秀丽

每一套产品出厂时都会进行特性试验，绘出相应的特性曲线，工程技术人员在使用传感器的时候必须仔细研究配套的校验证书，认真分析特性曲线，以确定传感器是否满足所要测量的间隙，一般传感器直径越大所测量间隙也越大。所以，这个间隙参数没有固定值，和很多因素都有关系，出厂时候会根据客户不同的测量材质等情况，实际测试后标明。

Each set of products will be carried out characteristic test, draw the corresponding characteristic curve, engineering and technical personnel must carefully study the matching verification certificate when using the sensor, carefully analyze the characteristic curve, to determine whether the sensor meets the gap to be measured, generally the larger the diameter of the sensor the larger the measured gap. Therefore, this gap parameter has no fixed value, and many factors are related to the factory will be according to the customer's different measurement materials and other conditions, the actual test marked.

以上仅为出厂检测报告举例，传感器的型号不同，出厂检测报告中的参数也各有不同，具体参数以传感器出厂时附带的检测报告为准。

The above is only an example of the factory test report, the sensor model is different, the factory test report parameters are also different, the specific parameters of the sensor shipped with the test report prevail.



辐射全国 放眼世界

Radiate nationwide and look around the world

质量第一

Quality First

用户至上

User First

诚信为本

Honesty is the best policy

以技术创新为核心，以客户需求为导向

Centered on technological innovation and guided by customer needs

将致力于位移、物位、角度等测控领域

We will be committed to the measurement and control fields of displacement, level, angle, etc

为客户提供一站式解决方案的产品与服务

Provide customers with one-stop solutions for products and services

版权归深圳市米朗科技有限公司所有
Copyright belongs to Shenzhen Miran Technology Co., Ltd

本选型样本如有变动，恕不另行通知，以最新版本为准
This selection sample is subject to change without prior notice, and the latest version shall prevail

任何拷贝、复制、拍摄制作作为商业用途均属于侵权
Any copy, reproduction, filming and production for commercial purposes is infringing

主要著作人：李工
Main author: Engineer Li

2024年07月出品
Produced in July 2024