

中国工信部高精度传感器一条龙应用计划示范项目

国家级专精特新“小巨人”企业，国家级高新技术企业

中国工业强基重点产品，中国工信部传感器一条龙应用计划示范企业

# 拉绳/拉线式位移传感器

ROPE/PULL TYPE DISPLACEMENT SENSOR



# 拉绳/拉线式位移传感器

ROPE/PULL TYPE DISPLACEMENT SENSOR

- Demonstration project of one-stop application plan for high-precision sensors of Ministry of Industry and Information Technology of China
- National level specialized and special new "little giant" enterprise, national level high-tech enterprise
- Key products of strong industrial base in China, demonstration enterprise of sensor one-stop application plan of Ministry of Industry and Information Technology of China

# 目录CONTENTS

● 选型指引 Selection Guidelines	04
● 安装注意事项 Installation Precautions	05
● 安装说明 Installation Instructions	06
● 接线方式 Connection	07
● MPS-XXXS/XXS/XS 系列 MPS-XXXS/XXS/XS Series	
● 产品实物图 Product physical pictures	08
● 产品概述 Overview	09
● 性能参数 Performance parameter	09
● 产品尺寸图 Product dimension diagram	
MPS-XXXS	11
MPS-XXS	12
MPS-XS	13
● MPS-S/M/L/XL 系列 MPS-S/M/L/XL Series	
● 产品实物图 Product physical pictures	14
● 产品概述 Overview	15
● 性能参数 Performance parameter	16
● 产品尺寸图 Product dimension diagram	
MPS-S	19
MPS-M	20
MPS-L	21
MPS-XL	22
● MBA-MPS 本安防爆系列 MBA-MPS Explosion-Proof Series	
● 检测证书 Testing certificate	23
● SM 系列 SM Series	
● 产品实物图 Product physical pictures	25
● 产品概述 Overview	25
● 性能参数 Performance parameter	26
● 产品尺寸图 Product dimension diagram	
SM-S	27
SM-M	28
● WEP 系列 WEP Series	
● 产品实物图 Product physical pictures	29
● 产品概述 Overview	29
● 性能参数 Performance parameter	30
● 产品尺寸图 Product dimension diagram	
WEP-S	31
WEP-M	32
● WS-S 系列 WS-S Series	



# 目录CONTENTS

● 产品实物图 Product physical pictures	33
● 产品概述 Overview	33
● 性能参数 Performance parameter	34
● 产品尺寸图 Product dimension diagram	35
<b>● MDS-S 系列 MDS-S Series</b>	
● 产品实物图 Product physical pictures	36
● 产品概述 Overview	36
● 性能参数 Performance parameter	37
● 产品尺寸图 Product dimension diagram	39
<b>● 防护罩系列 Protective Cover Series</b>	
● 产品实物及尺寸图 Product physical and dimensional drawings	40
<b>● MPSFS2 防水系列 MPSFS2 Waterproof Series</b>	
● 产品实物图 Product physical pictures	41
● 产品概述 Overview	42
● 性能参数 Performance parameter	43
● 产品尺寸图 Product dimension diagram	
MPSFS2-S	44
MPSFS2-M	44
MPSFS2-L	45
MPSFS2-XL	45
<b>● MPSZFS2 重载型防水系列 MPSZFS2 Heavy Duty Waterproof Series</b>	
● 产品实物图 Product physical pictures	46
● 产品概述 Overview	47
● 性能参数 Performance parameter	47
● 产品尺寸图 Product dimension diagram	48
<b>● MFB-MPSFS2 防水防爆系列 MFB-MPSFS2 Waterproof And Explosion-Proof Series</b>	
● 产品实物图 Product physical pictures	50
● 产品概述 Overview	51
● 性能参数 Performance parameter	51
● 产品尺寸图 Product dimension diagram	
MFB-MPSFS2-S	52
MFB-MPSFS2-M	52
MFB-MPSFS2-L	53
MFB-MPSFS2-XL	53
● 检测证书 Testing certificate	54
<b>● 荣誉证书 Certificate Of Honor</b>	55
<b>● 检测证书 Testing Certificate</b>	55
<b>● 应用领域 Application Area</b>	56

# 米朗拉绳/线位移传感器选型指引

## Selection Guidelines For Miran Rope/Line Displacement Sensors

### MPS - S - 500mm - R - C

**其他特殊附加要求:**

**空白:** 默认常规标准, 1米电源线; **EX:** 防爆型(所有防爆型需要有此后缀); **C:** 磁吸式安装方式(所有款型都可以做磁吸式); **G:** 标准挂扣式连接头; **G1:** 另一种挂扣式连接头; **GL:** 加装隔离电源模块, 4-20mA的加装该模块后, 输出是4-20mA四线制; 0-5V或者0-10V加装之后也是四线制电压输出, 要实现四线制, 由于空间限制, XXXS、XXS、XS、S型需要外加隔离电源模块, S型以上大小的可以内置。2m: 2米电源线; 3m: 3米电源线, 以此类推; 注意: 以上代码列举在一起的话, 代表以上几者参数同时包含, 如: "C2m" 代表磁吸式安装方式并且带2米电源线, 请按照上面的代码先后顺序列出。

**其他以上没有列出的附加要求请用文字描述:** 如拉绳方向与安装面垂直(大部分型号的拉绳方向与安装面平行)、外加铝合金防护外壳、外加塑胶防护外壳等。

**Other special additional requirements:**

**Blank:** Default conventional standard, 1 meter power cord; **EX:** explosion-proof type (all explosion-proof types need this suffix); **C:** magnetic installation mode (all models can be magnetic); **G:** Standard hook type connector; **G1:** Another hook type connector; **GL:** Equipped with isolated power module, 4-20mA After the module is installed, the output is 4-20mA four-wire system; 0-5V or 0-10V after installation is also a four-wire voltage output, to achieve four-wire system, due to space limitations, XXXS, XXS, XS, S type need additional isolation power module, S type above the size can be built in. 2m: 2m power cord; 3m: 3m power cord, and so on; Note: If the above code is listed together, it means that the above parameters are included at the same time, such as: "C2m" represents the magnetic installation mode and has a 2 meter power cord, please list it in the order of the above code. **Other additional requirements not listed above should be described in words:** for example, the direction of the cable is perpendicular to the mounting surface (the direction of the cable is parallel to the mounting surface in most models), an aluminum alloy protective shell, and a plastic protective shell.

**信号输出方式:**

**R:** 电位器输出/电阻输出(0-5K、0-10K可选); **V1:** 0-5V电压输出, 三线制; **V2:** 0-10V电压输出, 三线制; **A2:** 4-20mA电流输出, 二线制; **A3:** 4-20mA电流输出, 三线制; **FGA4:** 4-20mA电流输出, 非隔离四线制; **GLA4:** 4-20mA电流信号输出, 隔离四线制; (这种型号是传感器内部含隔离电源模块, 该输出信号的抗干扰能力比较强, 此隔离四线制模块可以内置在传感器内部(内置此模块要求安装底座在M型或者以上大小, M型以下安装底座则需要外置MOGLA4N或MOGLA4NR模块), 如需其他隔离四线制模块型号请参照我司隔离四线制模块选型表。**RS:** RS485数字信号输出; **S:** SSI数字信号输出; **P:** 脉冲信号输出, 可以装配各种类型编码器, 输出各种类型的脉冲信号或者绝对值编码器原理的数字信号、模拟信号(常规装配是NPN推挽式, 2000P/R的增量型编码器)。注: XXXS/XXS型默认电阻输出, 其他信号输出时需外加信号转换模块。XS、S型如果需要四线制电压或者四线制电流输出型, 需要外加电源隔离模块; SSI数字信号输出仅限于磁电编码器原理的拉绳位移传感器(MPSFS2、MPSZFS2、MFB-MPSFS2、MFB-MPSZFS2系列)。

**Signal output method:**

**R:** Potentiometer output/resistance output (0-5K, 0-10K optional); **V1:** 0-5V voltage output, three wire system; **V2:** 0-10V voltage output, three wire system; **A2:** 4-20mA current output, two wire system; **A3:** 4-20mA current output, three wire system; **FGA4:** 4-20mA current output, non-isolated four-wire system; **GLA4:** 4-20mA current signal output, isolated four-wire system; (This model contains an isolated power module inside the sensor, the output signal has a strong anti-interference ability, and the isolated four-wire mold block can be built inside the sensor (the built-in module requires the installation base to be M type or above size, and the installation base below M type requires an external MOGLA4N or MOGLA4NR module). If you need other isolated four-wire mold block models, please refer to our isolated four-wire mold block selection table. **RS:** RS485 digital signal output; **S:** SSI digital signal output; **P:** Pulse signal output, can be assembled with various types of encoders, output various types of pulse signals or absolute encoder principle of digital signals, analog signals (conventional assembly is NPN push-pull, 2000P/R incremental encoder). Note: XXXS/XXS type default resistance output, other signal output requires additional signal conversion module. XS, S type if you need four-wire voltage or four-wire current output type, you need additional power isolation module; SSI digital signal output is limited to the drawing displacement sensors based on the magnetolectric encoder principle (MPSFS2, MPSZFS2, MFB-MPSFS2, MFB-MPSZFS2 series).

**有效测量行程:** 100-35000mm之间任意量程可选, 单位: mm毫米, 一般建议选100的倍数量程, 或者参照米朗常规量程参考表, 货期会比较快, 特殊情况下也可以选择如658mm、5211mm等任意量程也可以生产, 这些不是常规量程的需要另外加工定做相应的线轮来生产, 货期会稍慢点。

**Effective measurement range:** Optional range between 100-35000mm, unit: mm mm, it is generally recommended to choose a multiple of 100 measuring range, or refer to the Milan conventional measuring range reference table, the delivery time will be faster, in special cases, you can also choose any measuring range such as 658mm, 5211mm, etc., can also be produced, these are not conventional measuring ranges need to be processed and customized corresponding wire wheels to produce, the delivery time will be slightly slower.

**安装基座型号大小(根据基座的大小选择相应范围的有效测量行程)**

**XXXS:** 100-350mm; **XXS:** 100-1000mm; **XS:** 100-1200mm; **S:** 100-1300mm; **M:** 1000-4000mm; **L:** 4500-10000mm; **XL:** 11000-35000mm; **ZM:** 100-4000mm; **ZL:** 4500-35000mm

(注: "S1"代表老款不带支架, 底部螺丝安装的; "ZM" "ZL"为重载型拉绳位移传感器(MPSZFS2/MFB-MPSZFS2)专用安装机座型号; 超出这些量程范围的, 可以联系我们沟通定制)。

**Installation base model size (select effective measurement stroke within the corresponding range based on the size of the base)**

**XXXS:** 100-350mm; **XXS:** 100-1000mm; **XS:** 100-1200mm; **S:** 100-1300mm; **M:** 1000-4000mm; **L:** 4500-10000mm; **XL:** 11000-35000mm; **ZM:** 100-4000mm; **ZL:** 4500-35000mm; (Note: "S1" represents the old model without a bracket, the bottom screw installation, "ZM" and "ZL" are the special mounting frame models for the heavy-duty cable displacement sensor (MPSZFS2/MFB-MPSZFS2); Beyond these ranges, you can contact us to communicate and customize).

**米朗拉绳位移传感器系列:**

**MPS、SM、WEP、MDS:** 普通标准型, 普通防水, 如: 可以承受短时间溅水, 短时间雨淋等。

**MPSFS2、MPSZFS2:** 防水型(磁感应)拉绳位移传感器, 绝对位置输出型, 采用特有的防水专利技术, 完全防水, 可以在深水中使用, 防护等级可达IP68。

**MFB-MPSFS2、MFB-MPSZFS2:** 防水防爆型(磁感应)拉绳位移传感器, 获得专业防爆证书, 采用米朗公司自主研发多圈磁感应绝对值编码器, 内部使用高强度灌密封胶封装, 从而保证磁感应绝对值编码器能够在水下长期正常工作。信号输出方式为电流4-20mA三线制、电压0-5V三线制、电压0-10V三线制、数字信号RS485。(有特殊要求可定制)

**MBA-MPS:** 本安防爆型拉绳位移传感器, MBA-MPS安装尺寸跟MPS安装尺寸相同, 内部核心部件为高精度、长寿命多圈电位计, 并获得本安防爆证书, 防爆标志为Ex ia IIB T6 Ga, 限电流二线制和RS485两种信号输出。

**注意:** 防水、防爆类型的产品, 均以MPS系列底座为主, 其他系列如需生产均为定制产品, 请与生产部门沟通后再确定。

**WS:** 出线口方向为万向型, 拉绳的出线口处可以斜着拉出来, 不需要与出线口的平面垂直。

**Miran rope displacement sensor series:**

**MPS, SM, WEP, MDS:** ordinary standard type, ordinary waterproof, such as being able to withstand short-term splashing, short-term rain, etc;

**MPSFS2, MPSZFS2:** Waterproof (magnetic induction) rope displacement sensor, absolute position output type, using unique waterproof patented technology, completely waterproof, can be used in deep water, protection level up to IP68.

**MFB-MPSFS2, MFB-MPSZFS2:** Waterproof and flameproof type (magnetic induction) rope displacement sensor, obtained professional flameproof certificate, adopts the multi-circle magnetic induction absolute encoder independently developed by Miran company, and uses high-strength pot-sealing sealant inside, so as to ensure that the magnetic induction absolute encoder can work normally under water for a long time. The signal output mode is current 4-20mA three-wire system, voltage 0-5V three-wire system, voltage 0-10V three-wire system, digital signal RS485. (customized with special requirements)

**MBA-MPS:** Intrinsic safety explosion-proof cable displacement sensor, MBA-MPS installation size is the same as MPS installation size, the internal core component is high-precision, long-life multi-turn potentiometer, and obtained the intrinsic safety explosion-proof certificate, explosion-proof mark is Ex ia IIB T6 Ga, limited current two-wire system and RS485 signal output.

**Attention:** Waterproof and explosion-proof products are mainly based on MPS series bases. If other series need to be produced, they are all customized products. Please communicate with the production department before determining.

**WS:** The direction of the outlet is universal, and the outlet of the pull rope can be pulled out diagonally without being perpendicular to the plane of the outlet.

**注:** 以上选型不代表每种组合的都会生产, 具体以实际生产情况沟通为准。

**Note:** The above selection does not mean that every combination will be produced. The specific production situation shall be subject to communication.

## ⚡ 安装注意事项 Installation Precautions

1、电气连接请按照传感器上的接线说明接线，确保传感器正确接线才能通电；利用底部固定螺丝孔或磁铁，依现场及机器安装空间设施需要，直接安装或另加保护或其他机械使用。

1. Please follow the wiring instructions on the sensor for electrical connections to ensure that the sensor is correctly wired before it can be powered on; The use of the bottom fixing screw hole or magnet, according to the site and machine installation space facilities need, direct installation or additional protection or other mechanical use.

2、不锈钢钢丝绳安装时，需确保拉线处于平行于出线口拉出，避免钢丝绳被出线口反复摩擦导致断裂；（不锈钢索安装时，使钢索绳由出线口至移动部位机件工作处于平行滑动，保持较小角度〔容许偏差正负3度〕，以确保测量精度及钢索之寿命）。

2. When installing stainless steel wire ropes, it is necessary to ensure that the pulling wire is pulled out parallel to the outlet to avoid the wire rope being repeatedly rubbed by the outlet and causing it to break; When installing stainless steel cables, the steel cable should slide parallel from the outlet to the moving parts, maintaining a small angle (allowable deviation of plus or minus 3 degrees) to ensure measurement accuracy and the lifespan of the steel cable.

3、保持较小角度（容许偏差 $\pm 3^\circ$ ）以确保量测精度及钢索之寿命。钢索本体是多股不锈钢钢丝SUS316材质，外层为尼龙涂层，请勿让其受外力的割伤、烧损、撞击等不当之事发生：过量的粉尘、积屑或是足以破坏钢索的物品贮留于内部的滑轮或出线口将造成钢索破损，导致运转不顺的故障。

3. Maintain a small Angle (tolerance  $\pm 3^\circ$ ) to ensure measurement accuracy and cable life. The steel cable body is multi-strand stainless steel wire SUS316 material, the outer layer is nylon coating, do not let it be cut by external force, burn, impact and other improper things occur: excessive dust, debris accumulation or enough to damage the steel cable stored in the internal pulley or outlet will cause damage to the steel cable, resulting in bad operation of the fault.

4、8米及以上拉绳尺（L型及XL型拉绳尺）为避免运输中传感器内部震动，装有锁止螺丝，使用前需拆除螺丝，拉绳才可顺畅拉出，若不拆除锁止螺丝，强行拉出拉绳，有可能会损坏拉绳尺。

4. In order to avoid the internal vibration of the sensor during transportation, the locking screws are installed. The screws must be removed before use, so that the rope can be pulled out smoothly. If the locking screws are not removed and the rope is pulled out forcibly, the rope ruler may be damaged.

5、S机座和M机座系列产品往复运动瞬间加速不可超过1米/秒；L机座和XL机座系列产品往复运动瞬间加速不可超过0.5米/秒；否则将导致钢索断裂，恕本公司不承担正常使用范围以外的责任。

5. The instantaneous acceleration of the reciprocating motion of the S and M base series products shall not exceed 1 meter/second. The instantaneous acceleration of the reciprocating motion of the L and XL base series products cannot exceed 0.5 meters per second. Otherwise, it will cause the steel cable to break, and our company does not assume any responsibility beyond the normal scope of use.

6、拉绳位移传感器属于精密仪器，请勿敲击或撞击，注意传感器和钢丝绳的清洁，以延长使用寿命；（钢索本体是不锈钢，外覆耐磨防腐塑胶层，请勿让其受外力的割伤、烧损、撞击等不当之事发生；过量的粉尘、积屑会破坏钢索或贮留于内部的滑轮，或将造成钢索破损，导致运转不顺的故障）。

6. The rope displacement sensor is a precision instrument. Do not knock or impact it. Pay attention to the cleanliness of the sensor and wire rope to extend its service life; (The steel cable body is made of stainless steel and covered with a wear-resistant and anti-corrosion plastic layer. Do not let it be cut, burned, or hit by external forces. Excessive dust and debris can damage the steel cable or the pulleys stored inside, or cause damage to the steel cable, resulting in poor operation).

## ⚡ 安装注意事项 Installation Precautions

7、未安装于工作台或固定坐前，请勿用手或是其它产品将钢索拉出并让其瞬间自行弹回，此举将造成钢索断裂，伤害本体结构及人身安全；拉线拉出后不要松开，需匀速拉出和缩回。

7. Do not use your hands or other products to pull out the steel cable before installation on the workbench or in front of the fixed seat, and let it instantly rebound on its own. This will cause the steel cable to break, damage the structure and personal safety of the body; After pulling out the cable, do not loosen it. It needs to be pulled out and retracted at a constant speed.

8、若使用于非直线运动的机构，请加装适当的滑轮运转；若使用于环境恶劣或特殊场合，请自行加装保护机构。

8. If used in the non-linear movement of the mechanism, please install the appropriate pulley operation; If used in bad environment or special occasions, please install your own protection mechanism.

注：若使用于室外或环境比较恶劣等特殊场合，可配置米朗防水防尘出线口和防护外壳，或请自行加装保护机构或与本公司联系定制加装保护机构，否则导致产品损坏，公司不予负责！

Note: If used in outdoor or harsh environments or other special occasions, Mirang waterproof and dustproof outlet and protective shell can be configured, or please install a protective mechanism yourself or contact our company to customize the installation of a protective mechanism. Otherwise, the company will not be responsible for product damage!

## ⚡ 安装说明 Installation Instructions

（因公司产品型号较多，安装方式也较多，有滑动支架螺丝安装式、固定螺丝孔安装式、磁吸式等），以下为常见的滑动支架螺丝安装式举例说明：

(Due to the variety of product models and installation methods in the company, there are sliding bracket screw installation, fixed screw hole installation, magnetic suction installation, etc.) The following are common examples of sliding bracket screw installation:

1. 先固定安装支架：将安装支架顺着传感器底部凹槽滑入，然后调整支架的位置，将螺丝插入安装孔固定在安装面；

1. Fix the mounting bracket first: slide the mounting bracket along the groove at the bottom of the sensor, then adjust the position of the bracket, insert the screw into the mounting hole and fix it on the mounting surface;

2. 测量端做L型销钉或者螺丝插入传感器安装头5mm的孔中固定传感器测头（或其它可靠连接方式）

2. Insert an L-shaped pin or screw into the 5mm hole of the sensor mounting head at the measuring end to fix the sensor measuring head (or other reliable connection methods)

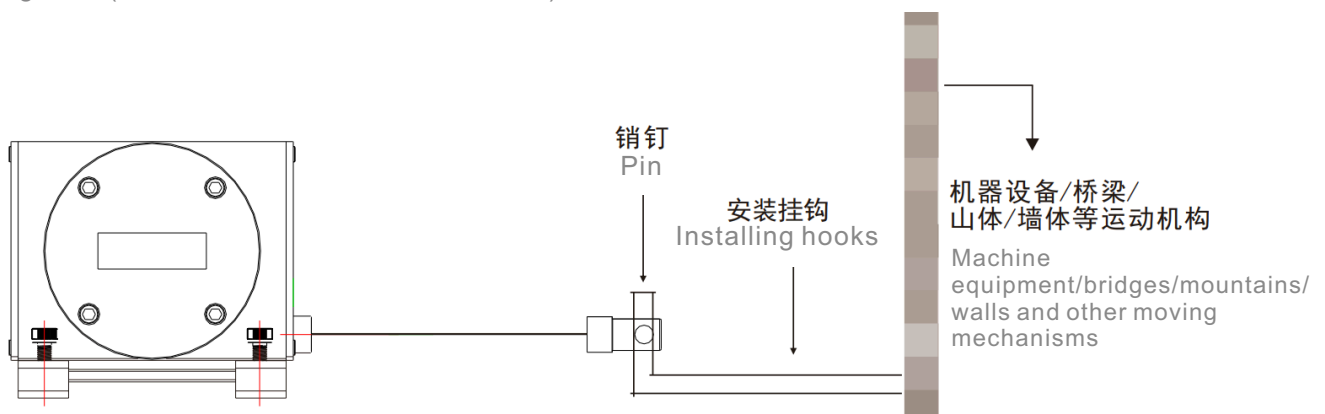

## SM/WS/MDS/MPS/MBA-MPS接线方式 Connection

电阻接线方式 Resistance wiring method	棕BROWN/红RED	蓝色 BLUE	黑色 BLACK	屏蔽线 Shielding wire		
	电源正 Power Positive DC5~10V	电源负 Power Negative 0V	输出 Output	接地 GROUNDING GND		
电压接线方式 Voltage wiring method 0-5V 0-10V	棕BROWN/红RED	蓝色 BLUE	黑色 BLACK	屏蔽线 Shielding Wire		
	电源正 Power Positive DC12~24V	电源负 Power Negative 0V	输出 Output	接地 GROUNDING GND		
电流接线方式 Current wiring method 4-20mA 2线制 2-Wire system	棕BROWN/红RED	黑色 BLACK	屏蔽线 Shielding Wire			
	电源正 Power Positive DC12~24V	输出 Output	接地 GROUNDING GND			
电流接线方式 Current wiring method 4-20mA 3线制 3-Wire system	棕BROWN/红RED	蓝色 BLUE	黑色 BLACK	屏蔽线 Shielding Wire		
	电源正 Mains positive DC12~24V	电源负 Power Negative 0V	输出 Output	接地 GROUNDING GND		
电流接线方式 Current wiring method 4-20mA 4线制 4-Wire system	棕BROWN/红RED	蓝色 BLUE	黑色 BLACK	白色 WHITE	屏蔽线 Shielding Wire	
	电源正 Power Positive DC12~24V	输出 + Output +	电源负 Power Negative 0V	输出 - Output -	接地 GROUNDING GND	
数字信号接线方式 Digital signal wiring method RS485	棕BROWN/红RED	蓝色/绿色 BLUE/GREEN	黑色 BLACK	白色 WHITE	屏蔽线 Shielding Wire	
	电源正 Power Positive DC12~24V	RS485 A	电源负 Power Negative 0V	RS485 B	接地 GROUNDING GND	
脉冲信号接线方式 Pulse signal wiring method NPN 标准 Standard	棕BROWN/红RED	蓝色 BLUE	绿色 GREEN	黄色 YELLOW	白色 WHITE	屏蔽线 Shielding Wire
	电源正 Power Positive DC5~30V	A相 A Phase	B相 B Phase	Z相 Z Phase	电源负 Power Negative 0V	接地 GROUNDING GND

## MPSFS2/MPSZFS2/MFB-MPSFS2接线方式 Connection

电流接线方式 Current wiring method	红色 RED	黑色 BLACK	绿色/黄色 GREEN/YELLOW	屏蔽线 Shielding Wire		
	电源正 Power Positive DC12~24V	电源负 Power Negative 0V	输出 Output 4-20mA	接地 GROUNDING GND		
电压接线方式 Voltage wiring method	红色 RED	黑色 BLACK	绿色/黄色 GREEN/YELLOW	屏蔽线 Shielding Wire		
	电源正 Power Positive DC12~24V	电源负 Power Negative 0V	输出 Output 0-5V, 0-10V	接地 GROUNDING GND		
数字信号接线方式 Digital signal wiring method RS485	红色 RED	黑色 BLACK	绿色/黄色 GREEN/YELLOW	屏蔽线 Shielding Wire	白色 WHITE	
	电源正 Power Positive DC12~24V	电源负 Power Negative 0V	RS485 A	接地 GROUNDING GND	RS485 B	
SSI接线方式 SSI wiring method	红色 RED	黑色 BLACK	绿色 GREEN	黄色 YELLOW	蓝色 BLUE	白色 WHITE
	电源正 Power Positive DC12~24V	电源负 Power Negative 0V	D+	C-	C+	D-



# MPS-XXXS/XXS/XS 拉绳位移传感器

MPS-XXXS/XXS/XS Rope Displacement Sensor

## 产品实物图 Physical Products Pictures

### MPS-XXXS



### MPS-XXS



### MPS-XS





## 产品概述 Overview

MPS-XXXS、MPS-XXS、MPS-XS 拉绳位移传感器，又称拉绳裂缝计，裂缝位移传感器，拉绳编码器，拉绳尺，拉线尺，拉线编码器，拉线位移传感器，是直线位移传感器在结构上的精巧集成，充分结合了角度传感器和直线位移传感器的优点，成为一款结构紧凑、测量行程长、安装空间尺寸小、具有高精度测量的优良传感器。该拉绳位移传感器系列产品具有很大的选择空间，MPS-XXXS行程从100mm至350mm不等，MPS-XXS行程从100mm至1000mm不等，MPS-XS行程从100mm至1200mm不等，具有模拟电流信号A2：4-20mA电流输出二线制，电流信号A3：4-20mA电流输出三线制，电流信号A4：4-20mA电流输出四线制；模拟电压信号V1：0-5V；V2：0-10V和脉冲信号P：A、B、Z相数字输出，RS485数字信号输出。满足大行程、高精度各种信号需求。

MPS-XXXS, MPS-XXS, and MPS-XS rope displacement sensors, also known as rope crack gauges, crack displacement sensors, rope encoders, rope rulers, rope rulers, rope encoders, and rope displacement sensors, are exquisite integrations of linear displacement sensors in structure. They fully combine the advantages of angle sensors and linear displacement sensors, making them a compact structure, long measurement stroke, and small installation space Excellent sensor with high-precision measurement. The rope displacement sensor series has a large selection space, with MPS-XXXS stroke ranging from 100mm to 350mm, MPS-XXS stroke ranging from 100mm to 1000mm, and MPS-XS stroke ranging from 100mm to 1200mm. It has an analog current signal A2: 4-20mA current output two wire system; Current signal A3: 4-20mA current output three wire system; Current signal A4: 4-20mA current output four wire system; Simulated voltage signal V1: 0-5V; V2: 0-10V and pulse signal P: A, B, Z-phase digital output, RS485 digital signal output. Meet various signal requirements for long travel and high precision.

## 性能参数 Performance Parameter

### 性能指标 Performance Index

产品系列 Product series	型号 Model	信号输出方式 Signal output mode
XXXS型 XXXS Type	MPS-XXXS-(100mm-350mm)-R	电阻：0-5k（默认）该信号最长非标做到350mm， Resistance: 0-5k (default) The maximum non-standard length of this signal is 350mm,
XXS型 XXS Type	MPS-XXS-(100mm-1000mm)-R	电阻：0-5K（默认）或者0-10K（精度高些，选配） Resistance: 0-5k (default) or 0-10K (higher accuracy, optional)
如需要电压、电流或者数字信号输出方式，可以另加变送器；如需要脉冲信号输出，需要选配小编码器 If voltage, current or digital signal output method is required, an additional transmitter can be added; If pulse signal output is required, a small encoder needs to be selected and equipped		
XS型 XS Type	MPS-XS-(100mm-1200mm)-R	电阻：0-5K（默认）或者0-10K（精度高些，选配） Resistance: 0-5K (default) or 0-10K (higher accuracy, optional)
XS型 XS Type	MPS-XS-(100mm-1200mm)-V1/V2	V1:电压（0-5V）或V2（0-10V） V1: Voltage (0-5V) or V2 (0-10V)
XS型 XS Type	MPS-XS-(100mm-1200mm)-A1/A2	电流（4-20mA）A1:3线制或A2:2线制 Current (4-20mA) A1:3 wire or A2:2 wire
XS型 XS Type	MPS-XS-(100mm-1200mm)-P	常规编码器脉冲输出 Conventional encoder pulse output
XS型 XS Type	MPS-XS-(100mm-1200mm)-RS	RS485数字信号输出 RS485 digital signal output

性能参数 Performance Parameter

⚡ 电气指标 Electrical Specifications

MPS-XXXS、MPS-XXS、MPS-XS拉绳位移传感器 MPS-XXXS, MPS-XXS, MPS-XS Rope displacement sensors	
线性精度 Linear accuracy	600mm以下±0.25%FS, 600mm以上±0.1%FS Below 600mm ± 0.25% FS, above 600mm ± 0.1% FS
重复性精度 Repeatability accuracy	±0.02%FS
线径规格 Wire diameter specification	直径0.8mm的多股不锈钢钢丝SUS316材质, 外层为尼龙涂层, 负载为16kg 0.8mm diameter multi strand stainless steel wire SUS316 material, with an outer layer of nylon coating and a load of 16kg
拉力 Pulling	<600g
最大往复速度 Maximum reciprocating speed	500mm/秒 500mm/second
保护等级 Protection level	IP65 (只适用于外壳) IP65 (Only applicable to the shell)
重量 Weight	≤600g
输入电阻值 Input resistance value	5kΩ ± 10%FS, 10kΩ ± 10%FS
功率 Power	70°C时1W (行程500mm), 70°C时2W (行程1000mm) 1W at 70 °C (travel 500mm), 2W at 70 °C (travel 1000mm)
传感器 Sensor	1. 绕线式多圈电位器; 2. 光栅式多圈编码器; 3. 磁感应(磁电)多圈位置传感器 1. Wire wound multi turn potentiometer; 2. Raster type multi turn encoder; 3. Magnetic induction (magneto electric) multi turn position sensor
储存环境 Environment	-20°C ~ +80°C
震动 Vibrate	10HZ-2000HZ
可选输出信号 Optional output signal	电位计输出 (DC5-10V), 电流/电压/RS485信号输出 (DC12-24V), 脉冲信号输出 (DC5-30V) Potentiometer output (DC5-10V), current/voltage/RS485 signal output (DC12-24V), pulse signal output (DC5-30V)
工作温度 Operation temperature	-20°C~+75°C (低温状态下, 需保持无结晶状态; 涂抹防冻液最低工作温度可达-35°C; 脉冲输出工作温度为-10°C~65°C) -20°C~+75°C (at low temperature, it should be kept in a non-crystalline state; The minimum working temperature of applying antifreeze can reach -35°C; Pulse output operating temperature is -10°C~65°C)

产品尺寸图 Product Dimension Diagram

MPS-XXXS

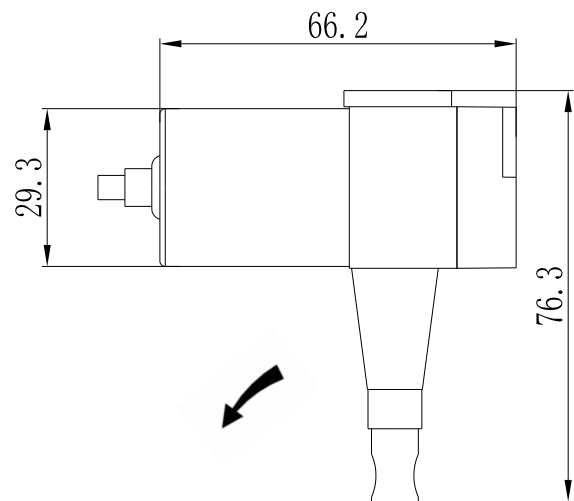
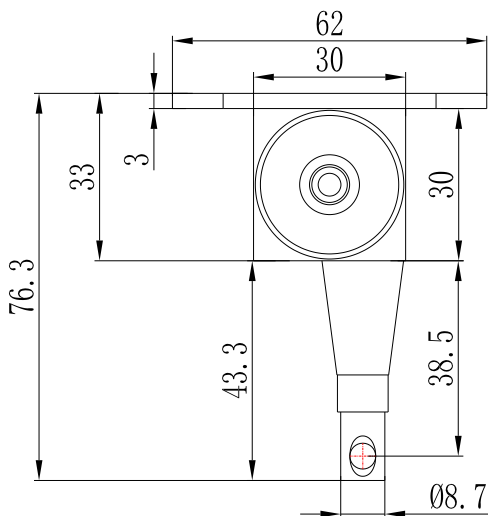
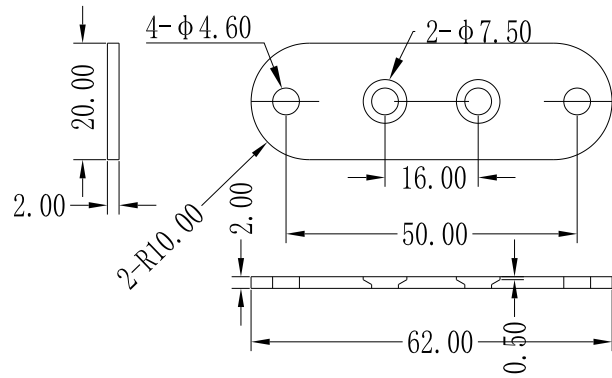

默认拉绳头尺寸 (线径0.8mm):

Default rope head size (Wire diameter 0.8mm):

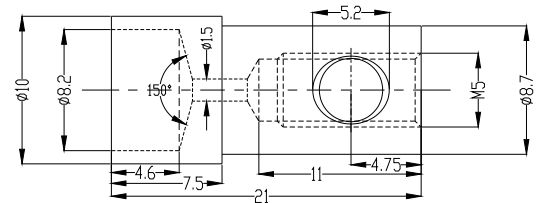

可选拉绳头尺寸 (线径1.5mm):

Optional rope head size (Wire diameter 1.5mm):

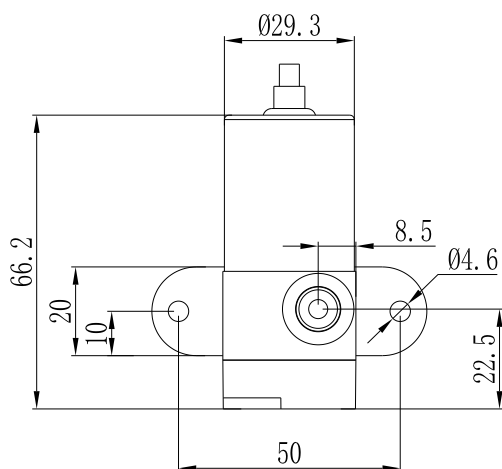
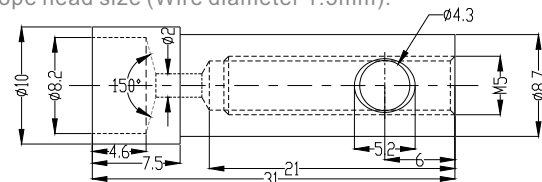

MPS-XXS

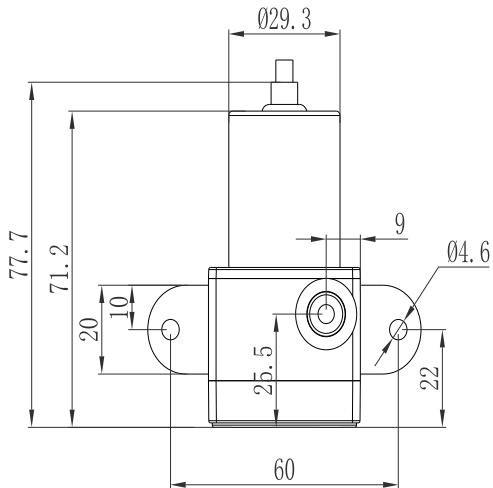
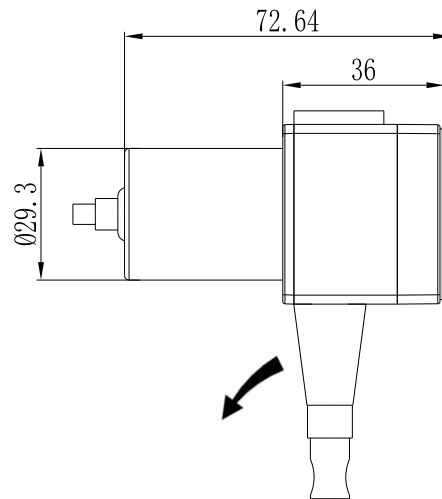
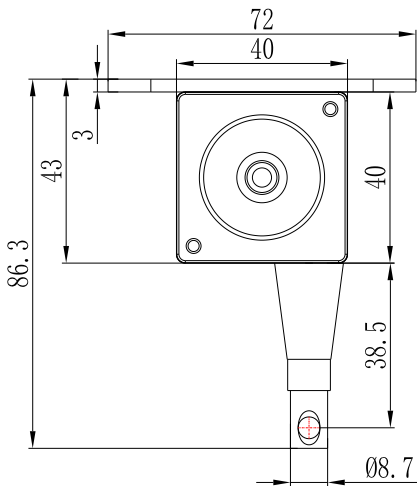
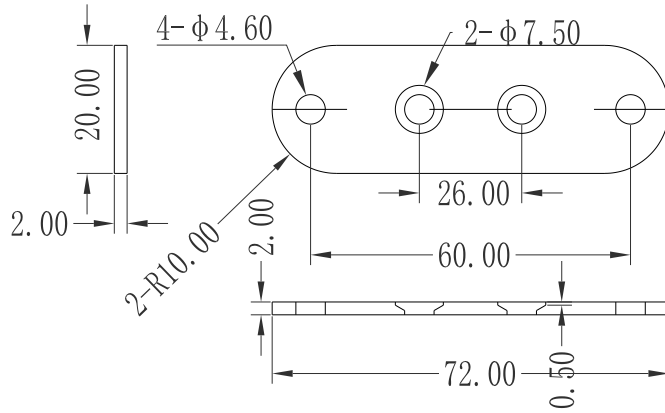

默认拉绳头尺寸(线径0.8mm):

Default rope head size(Wire diameter 0.8mm):

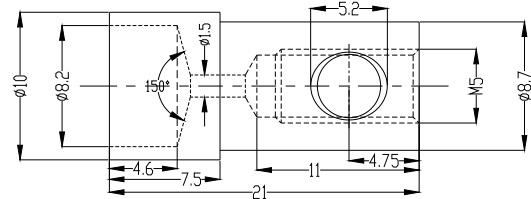

可选拉绳头尺寸(线径1.5mm):

Optional rope head size (Wire diameter 1.5mm):

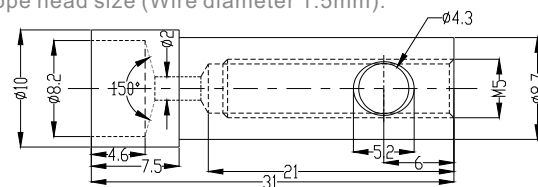

MPS-XS

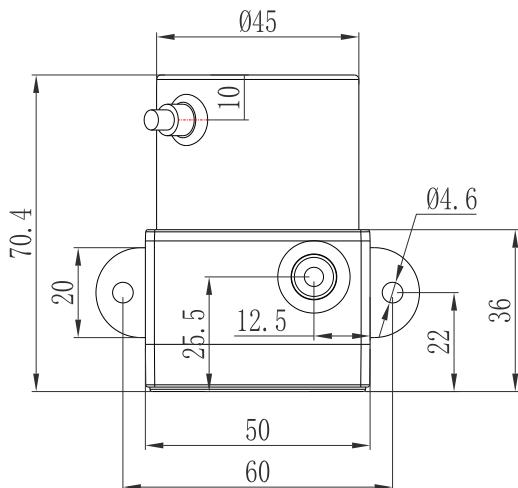
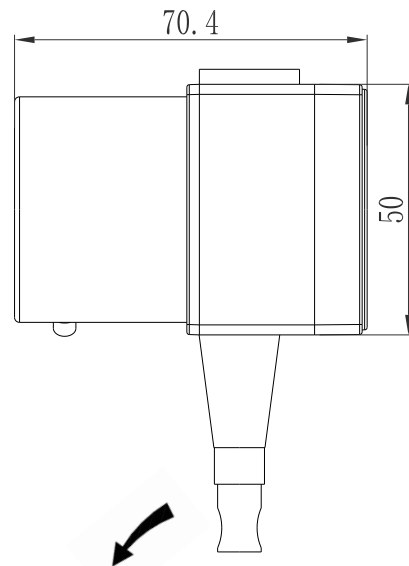
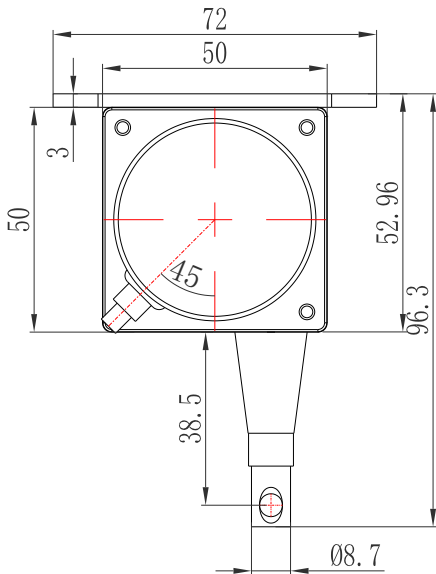
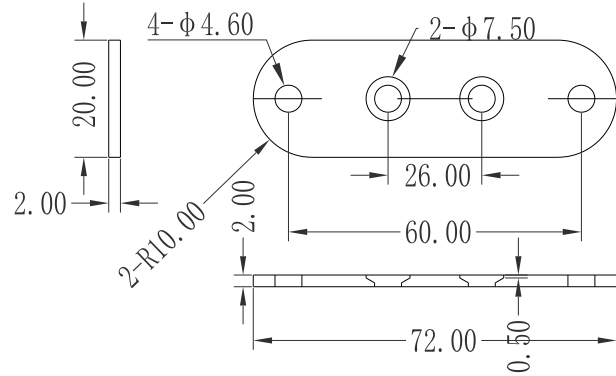

默认拉绳头尺寸(线径0.8mm):

Default rope head size(Wire diameter 0.8mm):

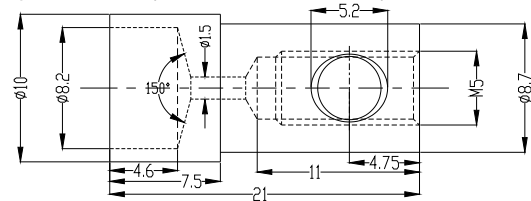

可选拉绳头尺寸(线径1.5mm):

Optional rope head size (Wire diameter 1.5mm):

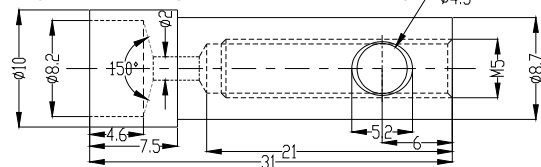

# MPS-S/M/L/XL 拉绳位移传感器

## MPS-S/M/L/XL Rope Displacement Sensor

### 产品实物图 Product Physical Pictures

#### MPS-S

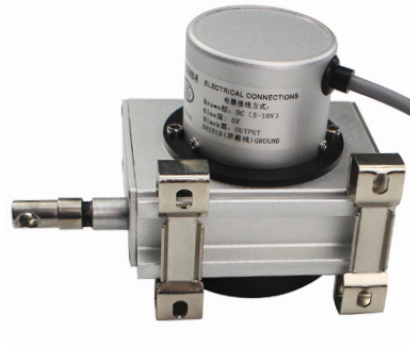
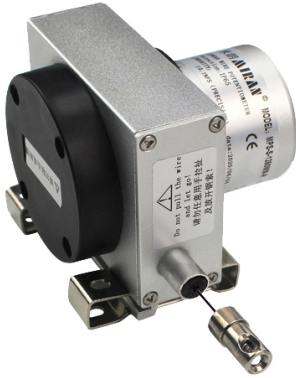

#### MPS-M

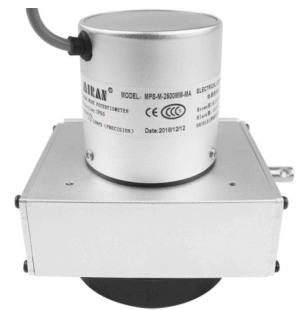

#### MPS-L

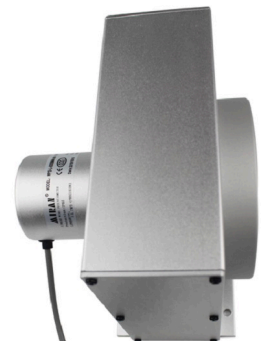
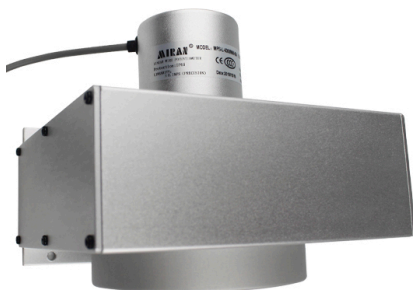



## 产品实物图 Physical Products Pictures

### MPS-XL

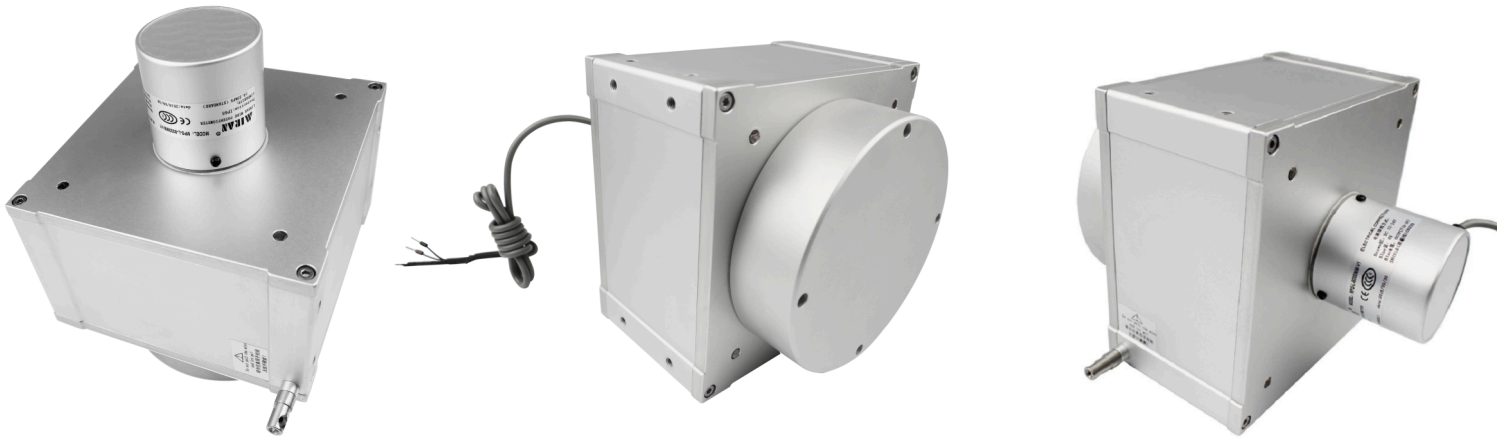

## 产品概述 Overview

MPS-S/M/L/XL系列拉线位移传感器，又称拉绳编码器，拉绳尺，拉线尺，拉线编码器，拉绳位移传感器，是直线位移传感器在结构上的精巧集成，充分结合了角度传感器和直线位移传感器的优点，成为一款结构紧凑、测量行程长、安装空间尺寸小、具有高精度测量的优良传感器。MPS-S/M/L/XL系列拉线位移传感器系列产品具有很大的选择空间，行程从100mm至35000mm不等，具有模拟电流信号A2：4-20mA电流输出二线制，电流信号A3：4-20mA电流输出三线制，电流信号A4：4-20mA电流输出四线制；模拟电压信号V1：0-5V，V2：0-10V和脉冲信号P：A、B、Z相数字输出；RS485数字信号输出。满足大行程、高精度各种信号需求。

MPS-XXXS, MPS-XXS, and MPS-XS rope displacement sensors, also known as rope crack gauges, crack displacement sensors, rope encoders, rope rulers, rope rulers, rope encoders, and rope displacement sensors, are exquisite integrations of linear displacement sensors in structure. They fully combine the advantages of angle sensors and linear displacement sensors, making them a compact structure, long measurement stroke, and small installation space. Excellent sensor with high-precision measurement. The rope displacement sensor series has a large selection space, with MPS-XXXS stroke ranging from 100mm to 350mm, MPS-XXS stroke ranging from 100mm to 1000mm, and MPS-XS stroke ranging from 100mm to 1200mm. It has an analog current signal A2: 4-20mA current output two wire system; Current signal A3: 4-20mA current output three wire system; Current signal A4: 4-20mA current output four wire system; Simulated voltage signal V1: 0-5V; V2: 0-10V and pulse signal P: A, B, Z-phase digital output, RS485 digital signal output. Meet various signal requirements for long travel and high precision.

性能参数 Performance Parameter

⚡ 电气指标 Electrical Specifications

型号 Model	MPS-S拉绳位移传感器 MPS-S Rope displacement sensor
测量行程 Measuring stroke	(100mm-1300mm) 之间量程任意可选 (100mm-1300mm) Any range can be selected between
线性精度 Linear accuracy	600mm以下±0.25%FS, 600mm以上±0.1%FS Below 600mm ± 0.25% FS, above 600mm ± 0.1% FS
重复性精度 Repeatability accuracy	±0.02%FS
线径规格 Wire diameter specification	直径0.8mm的多股不锈钢钢丝SUS316材质, 外层为尼龙涂层, 负荷为16kg 0.8mm diameter multi strand stainless steel wire SUS316 material, with an outer layer of nylon coating and a load of 16kg
拉力 Pulling	< 600g
最大往复速度 Maximum reciprocating speed	500mm/秒 500mm/second
重量 Weight	≤ 600g
输入电阻值 Input resistance value	5kΩ ± 10%FS, 10kΩ ± 10%FS
功率 Power	70°C时1W (行程500mm), 70°C时2W (行程1000mm) 1W at 70°C (travel 500mm), 2W at 70°C (travel 1000mm)
传感器 Sensor	1. 绕线式多圈电位器; 2. 光栅式多圈编码器; 3. 磁感应 (磁电) 多圈位置传感器 1. Wire wound multi turn potentiometer; 2. Raster type multi turn encoder; 3. Magnetic induction (magneto electric) multi turn position sensor
储存环境 Environment	-20°C ~ +80°C
震动 Vibrate	10HZ-2000HZ
防护等级 Protection grade	IP65 (只限外壳) IP65 (Shell only)
可选输出信号 Optional output signal	电位计输出 (DC5-10V), 电流/电压/RS485信号输出 (DC12-24V), 脉冲信号输出 (DC5-30V) Potentiometer output (DC5-10V), current/voltage/RS485 signal output (DC12-24V), pulse signal output (DC5-30V)
工作温度 Operation temperature	-20°C ~ +75°C (低温状态下, 需保持无结晶状态; 涂抹防冻液最低工作温度可达-35°C; 脉冲输出工作温度为-10°C ~ 65°C) -20°C ~ +75°C (at low temperature, it should be kept in a non-crystalline state; The minimum working temperature of applying antifreeze can reach -35°C; Pulse output operating temperature is -10°C ~ 65°C)

 电气指标 Electrical Specifications

MPS-M拉绳位移传感器 MPS-M Rope displacement sensor			
测量行程 Measuring stroke	(1000~4000) mm之间行程任意可选 Optional stroke between (1000~4000) mm	寿命 Life	典型>1X10 <sup>6</sup> 循环 Typical>1X10 <sup>6</sup> cycles
起动转轴 Start shaft	≥600g	消耗电流 Consumption current	≤30mA
最大往复速度 Maximum reciprocating speed	1000mm/秒 1000mm/second	震动 Vibrate	10g (10±1500Hz)
储存温度 Storage temperature	-20℃~+80℃	重量 Weight	<1000g
拉力 Pulling	(行程<2米) 最大600g; (行程≥2米) 最大900g (Travel<2 meters) Maximum 600g; (Travel ≥ 2 meters) Maximum 900g		
线性精度 Linear accuracy	600mm以下±0.25%FS, 600mm以上±0.1%FS (Travel<2 meters) Maximum 600g; (Travel ≥ 2 meters) Maximum 900g		
传感器 Sensor	1. 绕线式多圈电位器; 2. 光栅式多圈编码器; 3. 磁感应(磁电)多圈位置传感器 1. Wire wound multi turn potentiometer; 2. Raster type multi turn encoder; 3. Magnetic induction (magneto electric) multi turn position sensor		
保护等级 Protection level	该产品保护等级为IP65 (只限外壳) The protection level of this product is IP65 (limited to the shell only)		
线径规格 Wire diameter specification	多股不锈钢钢丝SUS316材质, 外层为尼龙涂层, 直径1.5mm负荷为23kg; 直径0.8mm负荷为16kg Multi strand stainless steel wire SUS316 material, with an outer layer of nylon coating, with a diameter of 1.5mm and a load of 23kg; 0.8mm diameter with a load of 16kg		
可选输出信号 Optional output signal	电位计输出 (DC5-10V), 电流/电压/RS485信号输出 (DC12-24V), 脉冲信号输出 (DC5-30V) Potentiometer output (DC5-10V), current/voltage/RS485 signal output (DC12-24V), pulse signal output (DC5-30V)		
工作温度 Operation temperature	-20℃~+75℃ (低温状态下, 需保持无结晶状态; 涂抹防冻液最低工作温度可达-35℃; 脉冲输出工作温度为-10℃~65℃) -20℃~+75℃ (at low temperature, it should be kept in a non-crystalline state; The minimum working temperature of applying antifreeze can reach -35℃; Pulse output operating temperature is -10℃~65℃)		

MPS-M拉绳位移传感器 (脉冲输出) MPS-M Rope displacement sensor (pulse output)			
检测方式 Detection	增量型 Incremental	最大响应频率 Maximum response frequency	10kHz~50kHz
输出波形 Output waveform	脉冲方波 Pulse square wave	波形上下时间 Waveform up and down time	≤2
输出相 Output phase	AB相或ABZ相 AB phase or ABZ phase	相位差 Phase difference	A、B相异90℃+45℃ (T/4+T/8), Z相T+T/2 A. B phase 90℃+45℃ (T/4+T/8), Z phase T+T/2
解析 Analysis	1、0.5、0.2、0.1、0.05 (0.05mm仅用于行程: 500、1000、2000mm) 1. 0.5, 0.2, 0.1, 0.05 (0.05mm only for travel: 500, 1000, 2000mm)		

 电气指标 Electrical Specifications

型号 Model	MPS-L拉绳位移传感器 MPS-L Rope displacement sensor	保护等级 Protection level	IP65 (只限外壳) IP65 (Shell only)
测量行程 Measuring stroke	(4500mm~10000mm) 之间量程任意可选 Optional range between 4500mm and 10000mm	线性精度 Linear accuracy	600mm以下±0.25%FS, 600mm以上±0.1%FS Below 600mm ±0.25% FS, above 600mm ±0.1% FS
最大往复速度 Maximum reciprocating speed	600mm/秒 600mm/second	重复性精度 Repeatability accuracy	±0.05%FS
储存温度 Storage temperature	-20℃~+80℃	拉力 Pulling	≤2200g
线径规格 Wire diameter specification	直径1.5mm的多股不锈钢钢丝 SUS316材质, 外层为尼龙涂层 1.5mm diameter multi strand stainless steel wire SUS316 material with an outer layer of nylon coating	重量 Weight	≤3500g
震动 Vibrate	10Hz-2000Hz	供应电流 Supply current	最大25mA Maximum 25mA
传感器 Sensor	1. 绕线式多圈电位器; 2. 光栅式多圈编码器; 3. 磁感应(磁电)多圈位置传感器 1. Wire wound multi turn potentiometer; 2. Raster type multi turn encoder; 3. Magnetic induction (magneto electric) multi turn position sensor		
可选输出信号 Optional output signal	电位计输出(DC5-10V), 电流/电压/RS485信号输出(DC12-24V), 脉冲信号输出(DC5-30V) Potentiometer output (DC5-10V), current/voltage/RS485 signal output (DC12-24V), pulse signal output (DC5-30V)		
工作温度 Operation temperature	-20℃~+75℃ (低温状态下, 需保持无结晶状态; 涂抹防冻液最低工作温度可达-35℃; 脉冲输出工作温度为-10℃~65℃) -20℃~+75℃ (at low temperature, it should be kept in a non-crystalline state; The minimum working temperature of applying antifreeze can reach -35℃; Pulse output operating temperature is -10℃~65℃)		

型号 Model	MPS-XL拉绳位移传感器 MPS-XL Rope displacement sensor	保护等级 Protection level	IP65 (只限外壳) IP65 (Shell only)
测量行程 Measuring stroke	(11000~35000)mm之间行程任意可选 Optional stroke between 11000-35000 mm	线性精度 Linear accuracy	600mm以下±0.25%FS, 600mm以上±0.1%FS Below 600mm ±0.25% FS, above 600mm ±0.1% FS
重复性精度 Repeatability accuracy	±0.02%FS	最大往复速度 Maximum reciprocating speed	600mm/秒 600mm/second
储存温度 Storage temperature	-20℃~+80℃	拉力 Pulling	≤2200g
线径规格 Wire diameter specification	直径1.5mm的多股不锈钢钢丝 SUS316材质, 外层为尼龙涂层 1.5mm diameter multi strand stainless steel wire SUS316 material with an outer layer of nylon coating	输入电阻值 Input resistance value	5kΩ ±10%FS, 10kΩ ±10%FS
震动 Vibrate	10Hz-2000Hz	额定功率 Rated power	2W在70℃时 2W at 70℃
传感器 Sensor	1. 绕线式多圈电位器; 2. 光栅式多圈编码器; 3. 磁感应(磁电)多圈位置传感器 1. Wire wound multi turn potentiometer; 2. Raster type multi turn encoder; 3. Magnetic induction (magneto electric) multi turn position sensor		
可选输出信号 Optional output signal	电位计输出(DC5-10V), 电流/电压/RS485信号输出(DC12-24V), 脉冲信号输出(DC5-30V) Potentiometer output (DC5-10V), current/voltage/RS485 signal output (DC12-24V), pulse signal output (DC5-30V)		
工作温度 Operation temperature	-20℃~+75℃ (低温状态下, 需保持无结晶状态; 涂抹防冻液最低工作温度可达-35℃; 脉冲输出工作温度为-10℃~65℃) -20℃~+75℃ (at low temperature, it should be kept in a non-crystalline state; The minimum working temperature of applying antifreeze can reach -35℃; Pulse output operating temperature is -10℃~65℃)		

产品尺寸图 Product Dimension Diagram

MPS-S

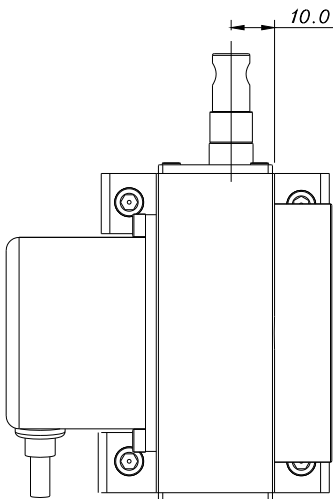
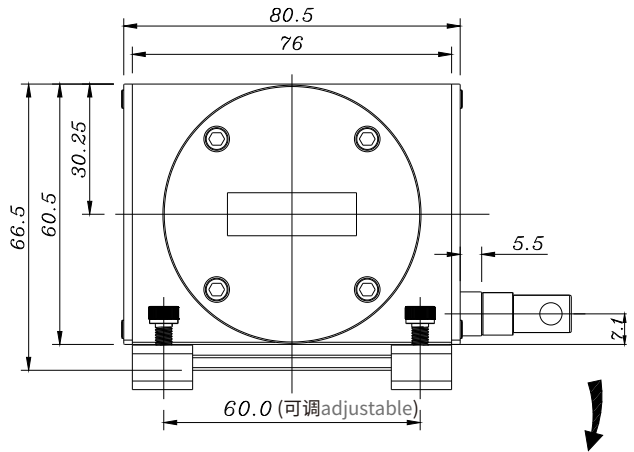
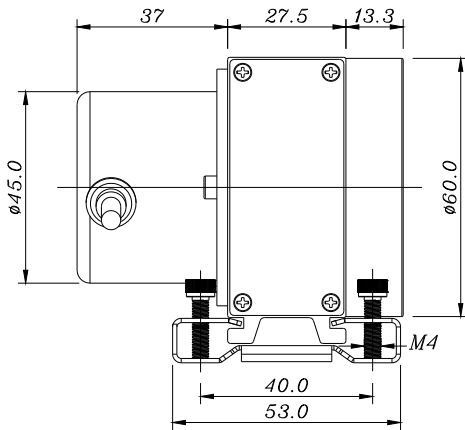
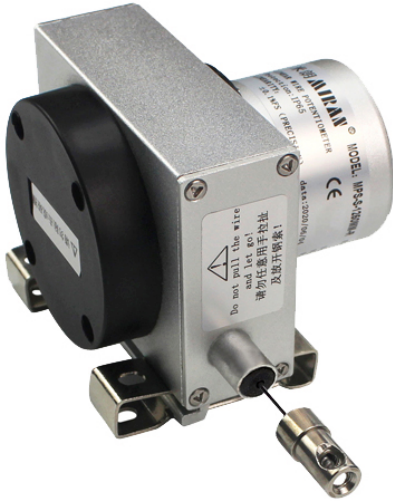

默认拉绳头尺寸(线径0.8mm):

Default rope head size (Wire diameter 0.8mm):

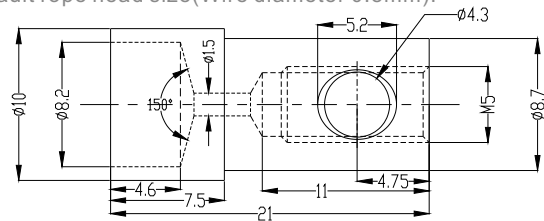

可选拉绳头尺寸(线径1.5mm):

Optional rope head size (Wire diameter 1.5mm):

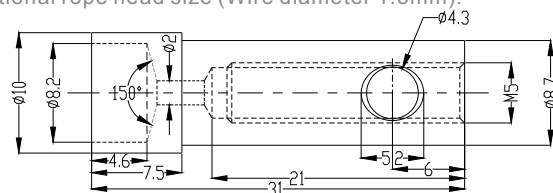

MPS-M

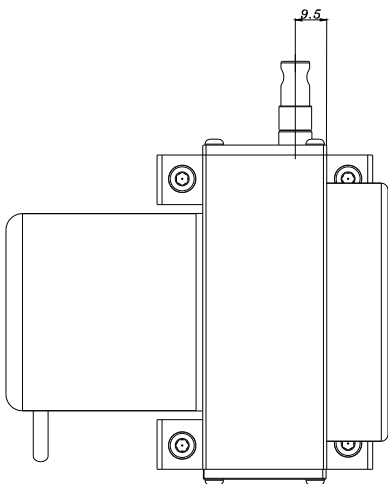
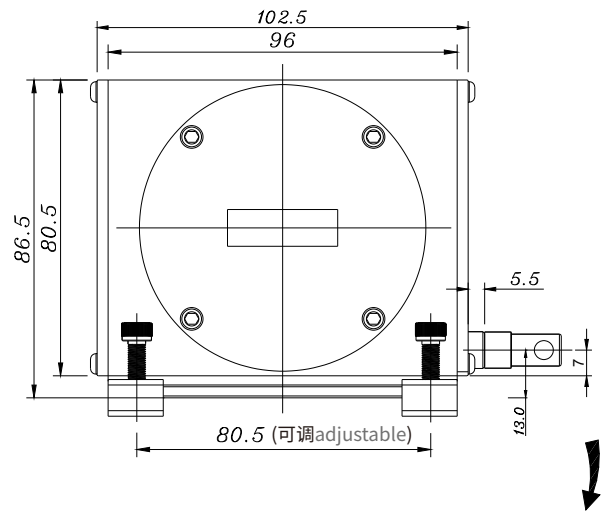
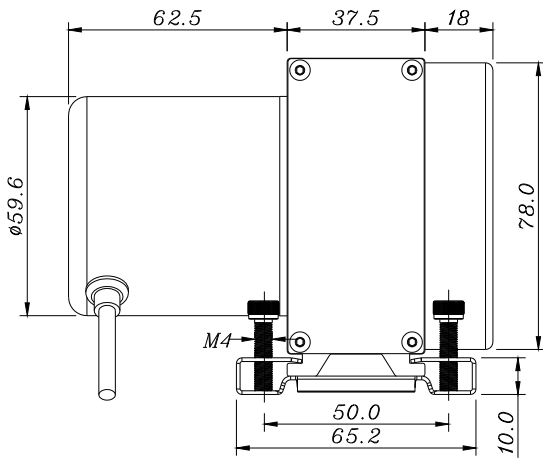

默认拉绳头尺寸(线径0.8mm):

Default rope head size(Wire diameter 0.8mm):

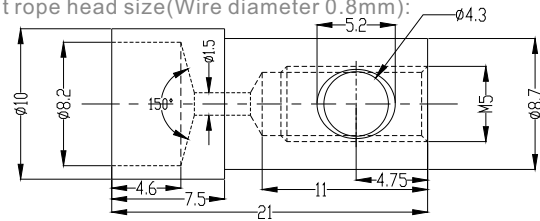

可选拉绳头尺寸(线径1.5mm):

Optional rope head size (Wire diameter 1.5mm):

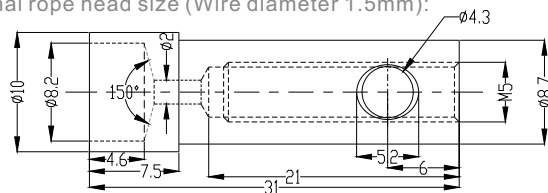



MPS-L

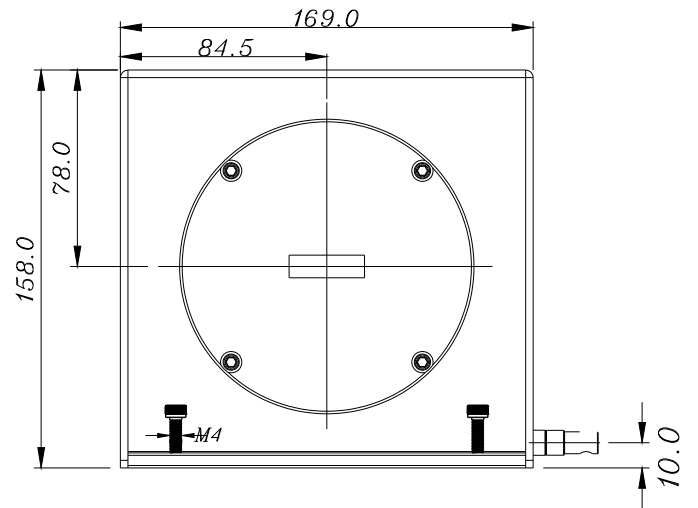
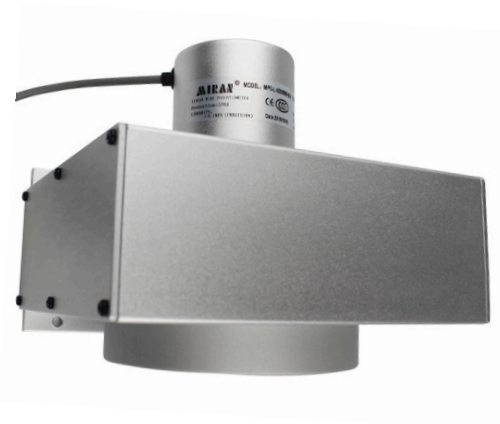
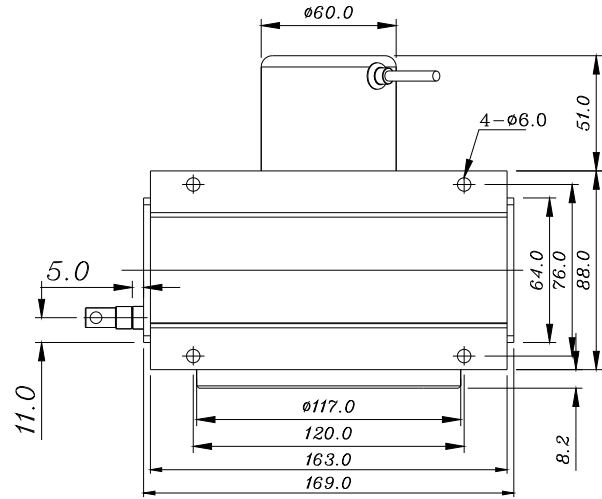

默认拉绳头尺寸(线径0.8mm):  
Default rope head size (Wire diameter 0.8mm):

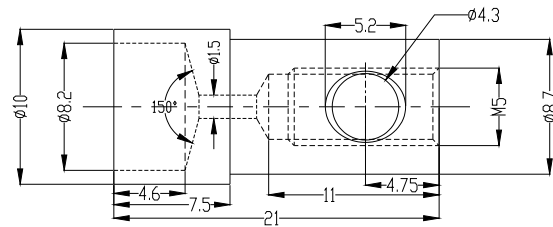

可选拉绳头尺寸(线径1.5mm):  
Optional rope head size (Wire diameter 1.5mm):

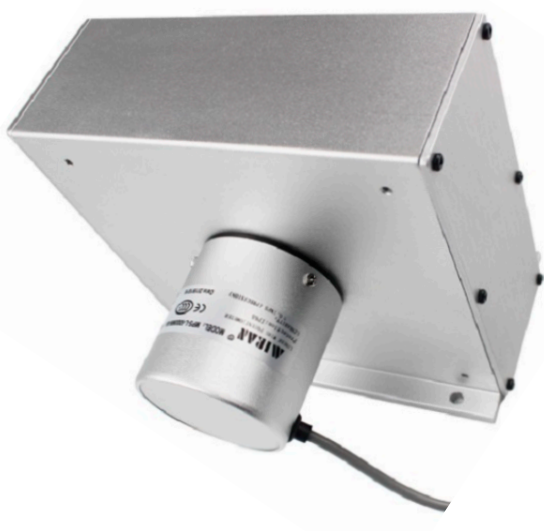
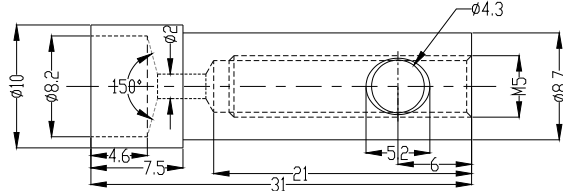

MPS-XL

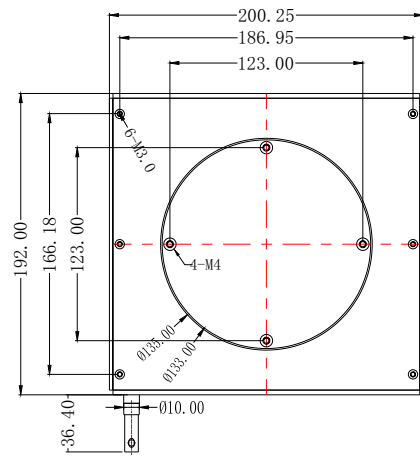
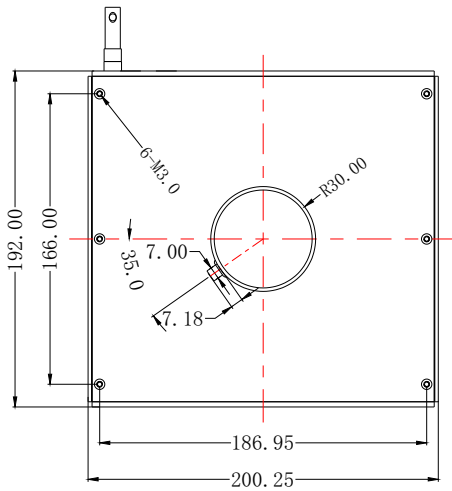
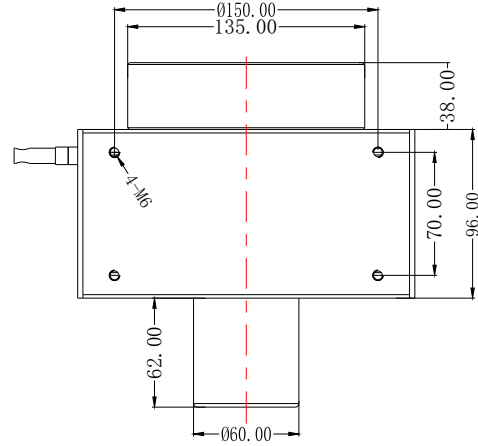
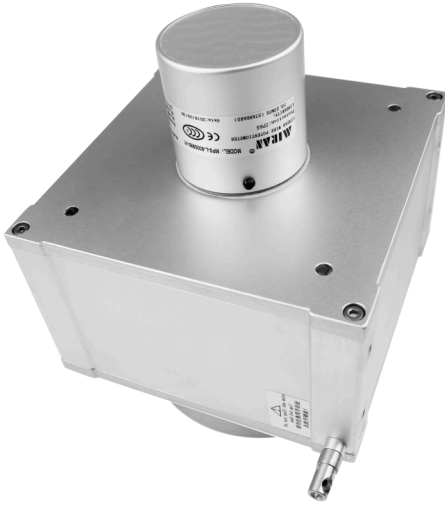

默认拉绳头尺寸(线径0.8mm):

Default rope head size (Wire diameter 0.8mm):

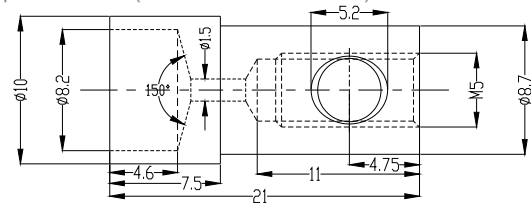

可选拉绳头尺寸(线径1.5mm):

Optional rope head size (Wire diameter 1.5mm):

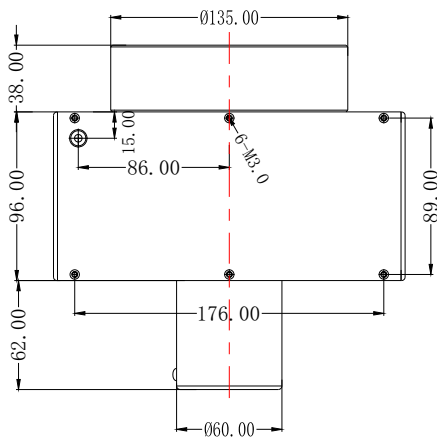
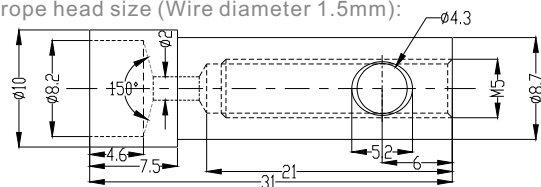

## MBA-MPS系列本安防爆拉绳位移传感器

MBA-MPS Series Intrinsic Safety Explosion-Proof Cable Displacement Sensor

检测证书 Testing Certificate

 国家防爆	编号: CNEx20.6245X
<h2>防爆合格证</h2>	
制造单位	深圳市米朗科技有限公司 (深圳市光明区公明街道上村社区红满庭红木文化创意园 A 栋 501)
产品名称	拉绳位移传感器
型号规格	MBA-MPS-mA 24VDC
防爆标志	Ex ia IIB T6 Ga
产品标准	Q/MLKJ02-2020
总装图号	MBA-MPS.00
<p>经对上述产品图样及技术文件的审查和样品检验,确认符合下列标准:            GB3836.1-2010《爆炸性环境 第1部分:设备 通用要求》            GB3836.4-2010《爆炸性环境 第4部分:由本质安全型“i”保护的的设备》            GB3836.20-2010《爆炸性环境 第20部分:设备保护级别(EPL)为Ga的设备》</p>	
<p>记事:            1、本产品用在0区时,应采取措施防止由于冲击或摩擦引起的点燃危险!            2、本安参数            电源端、4~20mA端均为: <math>U_i=28VDC</math>, <math>I_i=93mA</math>, <math>P_i=0.65W</math>, <math>C_i=0.04\mu F</math>, <math>L_i=0mH</math>。            3、产品使用的环境温度 <math>-20^{\circ}C \sim +60^{\circ}C</math>。</p>	
中心主任 	颁发日期 2020年12月18日
	本证有效期 2020年12月18日至2025年12月17日
 国家防爆电气产品质量监督检验中心 南阳防爆电气研究所	地址: 中国河南省南阳市仲景北路20号 邮政编码: 473008 电话: 0377-63258564 传真: 0377-63208175 网址: www.china-ex.com 
<small>注: 本证书仅对与认可文件和样品一致的产品有效。登录网站或关注公众号查询真伪 5845 0024 0884 5159 查询方式: www.china-ex.com</small>	

MBA-MPS系列为本安防爆型拉绳位移传感器, MBA-MPS系列安装尺寸及性能参数跟MPS系列相同, 内部核心部件为高精度、长寿命多圈电位计, 并获得本安防爆证书, 防爆标志为Ex ia IIB T6 Ga, 限电流二线制和RS485两种信号输出。

The MBA-MPS series is an intrinsically safe explosion-proof rope displacement sensor. The installation dimensions and performance parameters of the MBA-MPS series are the same as those of the MPS series. The internal core component is a high-precision, long-life multi turn potentiometer, and it has obtained an intrinsically safe explosion-proof certificate. The explosion-proof mark is Ex ia IIB T6 Ga, and there are two types of signal outputs: limited current two wire system and Rs485.



检测证书 Testing Certificate



**国家防爆**

编号: CNEx20.6246X

## 防爆合格证

制造单位	深圳市米朗科技有限公司 (深圳市光明区光明街道上村社区红满庭红木文化创意园 A 栋 501)		
产品名称	拉绳位移传感器		
型号规格	MBA-MPS-RS485	24VDC	
防爆标志	Ex ia IIB T6 Ga		
产品标准	Q/MLKJ02-2020		
总装图号	MBA-MPS.00		

经对上述产品图样及技术文件的审查和样品检验,确认符合下列标准:  
 GB3836.1-2010《爆炸性环境 第1部分:设备 通用要求》  
 GB3836.4-2010《爆炸性环境 第4部分:由本质安全型“i”保护的的设备》  
 GB3836.20-2010《爆炸性环境 第20部分:设备保护级别(EPL)为Ga的设备》

**记事:**

- 1、本产品用在0区时,应采取措施防止由于冲击或摩擦引起的点燃危险!
- 2、本安参数  
 电源端:  $U_i=28VDC$ ,  $I_i=93mA$ ,  $P_i=0.65W$ ,  $C_i=0.02\mu F$ ,  $L_i=0mH$ 。  
 RS485A-地, RS485B-地:  $U_i=10.5VDC$ ,  $I_i=100mA$ ,  $P_i=0.26W$ ,  $C_i=12\mu F$ ,  $L_i=0mH$ 。
- 3、产品使用的环境温度  $-20^{\circ}C \sim +60^{\circ}C$ 。

中心主任 

颁发日期 2020年12月18日

本证有效期 2020年12月18日至2025年12月17日





国家防爆电气产品质量监督检验中心  
南阳防爆电气研究所

地址: 中国河南省南阳市仲夏北路20号  
 邮政编码: 473008  
 电话: 0377-63285564  
 传真: 0377-63208175  
 网址: www.china-ex.com



公众号

注: 本证书仅对与认可文件和样品一致的产品有效。登录网站或关注公众号查询真伪 6788 2087 8173 6387 查询方式: www.china-ex.com

MBA-MPS系列为本安防爆型拉绳位移传感器, MBA-MPS系列安装尺寸及性能参数跟MPS系列相同, 内部核心部件为高精度、长寿命多圈电位计, 并获得本安防爆证书, 防爆标志为Ex ia IIB T6 Ga, 限电流二线制和RS485两种信号输出。

The MBA-MPS series is an intrinsically safe explosion-proof rope displacement sensor. The installation dimensions and performance parameters of the MBA-MPS series are the same as those of the MPS series. The internal core component is a high-precision, long-life multi turn potentiometer, and it has obtained an intrinsically safe explosion-proof certificate. The explosion-proof mark is Ex ia IIB T6 Ga, and there are two types of signal outputs: limited current two wire system and Rs485.

# SM系列拉绳位移传感器

## SM Series Rope Displacement Sensor

### 产品实物图 Product Physical Pictures

#### SM-S



#### SM-M



### 产品概述 Overview

SM-S/M系列拉线位移传感器，又称拉绳编码器，拉绳尺，拉线尺，拉线编码器，拉绳位移传感器，是直线位移传感器在结构上的精巧集成，充分结合了角度传感器和直线位移传感器的优点，成为一款结构紧凑、测量行程长、安装空间尺寸小、具有高精度测量的优良传感器。SM-S/M系列拉线位移传感器具有很大的选择空间，行程从100mm至2000mm不等，具有模拟电流信号A2：4-20mA电流输出二线制，电流信号A3：4-20mA电流输出三线制，电流信号A4：4-20mA电流输出四线制；模拟电压信号V1：0-5V，V2：0-10V，脉冲信号P：A、B、Z相数字输出，数字信号RS485。满足大行程、高精度各种信号需求。可应用于裂缝测量监测，桥梁测量监测，仓储位置定位，水库大坝保护，闸门开度控制，压力机械等方面。

The SM-S/M series cable displacement sensor, also known as the cable encoder, cable ruler, cable ruler, cable encoder, and cable displacement sensor, is a sophisticated integration of linear displacement sensors in structure, fully combining the advantages of angle sensors and linear displacement sensors. It has become an excellent sensor with compact structure, long measurement stroke, small installation space size, and high-precision measurement. The SM-S/M series cable displacement sensor has a large selection space, with travel ranging from 100mm to 2000mm. It has a two wire system for analog current signal A2: 4-20mA current output, a three wire system for current signal A3: 4-20mA current output, and a four wire system for current signal A4: 4-20mA current output; Simulated voltage signals V1: 0-5V, V2: 0-10V, pulse signals P: A, B, Z-phase digital output, digital signal RS485. Meet various signal requirements for long travel and high precision. It can be applied to crack measurement and monitoring, bridge measurement and monitoring, warehouse location positioning, reservoir dam protection, gate opening control, pressure machinery and other aspects.

## 性能参数 Performance Parameter

### ⚡ 电气指标 Electrical Specifications

型号 Model	SM-S/SM-M拉绳位移传感器 SM-S/SM-M Rope displacement sensor
重复性精度 Repeatability accuracy	±0.02%FS
保护等级 Protection level	IP65 (只限外壳) IP65 (Shell only)
震动 Vibrate	10Hz~2000Hz
输入电阻值 Input Resistance value	5kΩ ± 10%FS, 10kΩ ± 10%FS
储存温度 Storage temperature	-20℃~+80℃
功率 Power	70℃时1W (行程500mm), 70℃时2W (行程1000mm) 1W at 70℃ (travel 500mm), 2W at 70℃ (travel 1000mm)
传感器 Sensor	1. 绕线式多圈电位器; 2. 光栅式多圈编码器; 3. 磁感应(磁电)多圈位置传感器 1. Wire wound multi turn potentiometer; 2. Raster type multi turn encoder; 3. Magnetic induction (magneto electric) multi turn position sensor
可选输出信号 Optional output signal	电位计输出 (DC5-10V), 电流/电压/RS485信号输出 (DC12-24V), 脉冲信号输出 (DC5-30V) Potentiometer output (DC5-10V), current/voltage/RS485 signal output (DC12-24V), pulse signal output (DC5-30V)
工作温度 Operation temperature	-20℃~+75℃ (低温状态下, 需保持无结晶状态; 涂抹防冻液最低工作温度可达-35℃; 脉冲输出工作温度为-10℃~65℃) -20℃~+75℃ (at low temperature, it should be kept in a non-crystalline state; The minimum working temperature of applying antifreeze can reach -35℃; Pulse output operating temperature is -10℃~65℃)

### ⚡ 性能指标 Performance Index

型号 Model	SM-S拉绳位移传感器 (100mm-1000mm量程) SM-S Rope displacement sensor (100mm-1000mm range)	SM-M拉绳位移传感器 (1000mm-2000mm量程) SM-M Rope displacement sensor (1000mm-2000mm range)
重量 Weight	≤ 600g	≤ 1000g
拉力 Pulling	≤ 600g	(行程0-1250mm) 600g; (行程超过1500) 最大1000g (Travel 0-1250mm) 600g; (Travel over 1500) Maximum 1000g
线性精度 Linear accuracy	600mm以下 ±0.25%FS, 600mm以上 ±0.1%FS Below 600mm ± 0.25% FS, above 600mm ± 0.1% FS	600mm以下 ±0.25%FS, 600mm以上 ±0.1%FS Below 600mm ± 0.25% FS, above 600mm ± 0.1% FS
线径规格 Wire diameter specification	直径0.8mm的多股不锈钢钢丝SUS316材质, 外层为尼龙涂层, 负载16kg Multi strand stainless steel wire SUS316 with a diameter of 0.8mm, The outer layer is coated with nylon, with a load of 16kg	直径0.8mm/1.5mm的多股不锈钢钢丝SUS316材质, 外层为尼龙涂层 SUS316 material with multiple strands of stainless steel wire with a diameter of 0.8mm/1.5mm, The outer layer is coated with nylon
最大往复速度 Maximum reciprocating speed	500mm/秒 500mm/second	1000mm/秒 1000mm/second



产品尺寸图 Product Dimension Diagram

SM-S

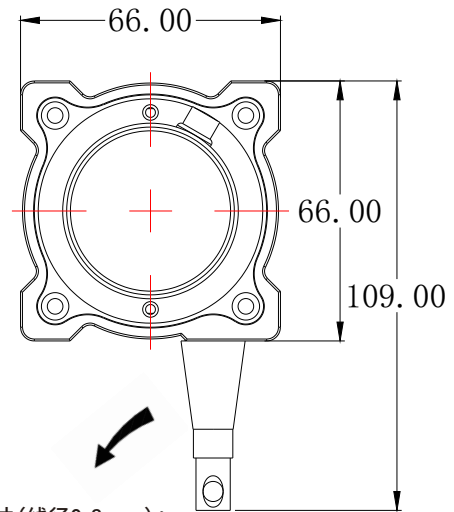
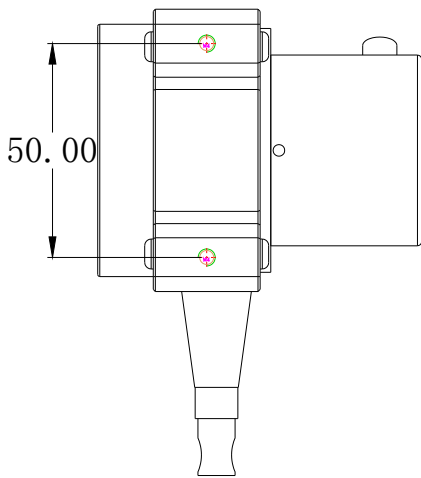
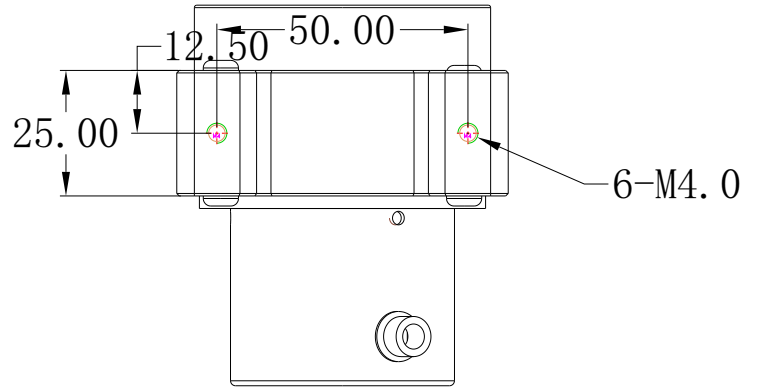

默认拉绳头尺寸 (线径0.8mm):

Default rope head size (Wire diameter 0.8mm):

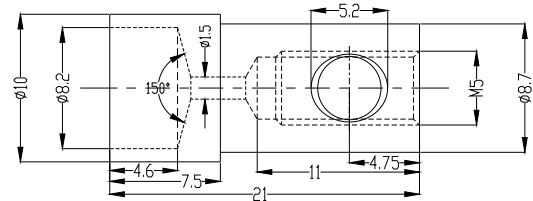

可选拉绳头尺寸 (线径1.5mm):

Optional rope head size (Wire diameter 1.5mm):

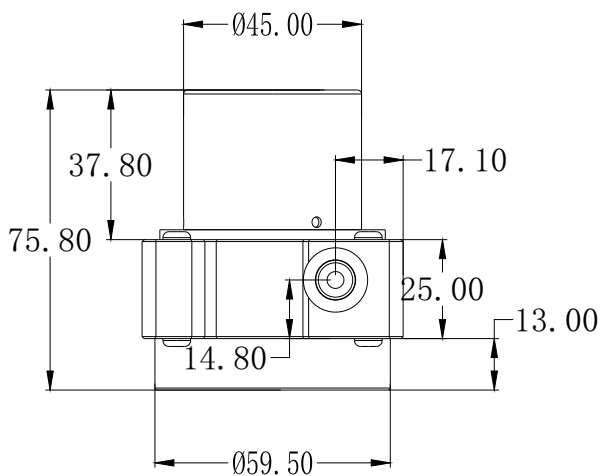
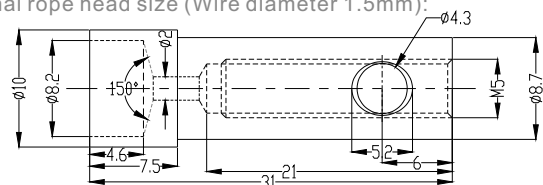

SM-M

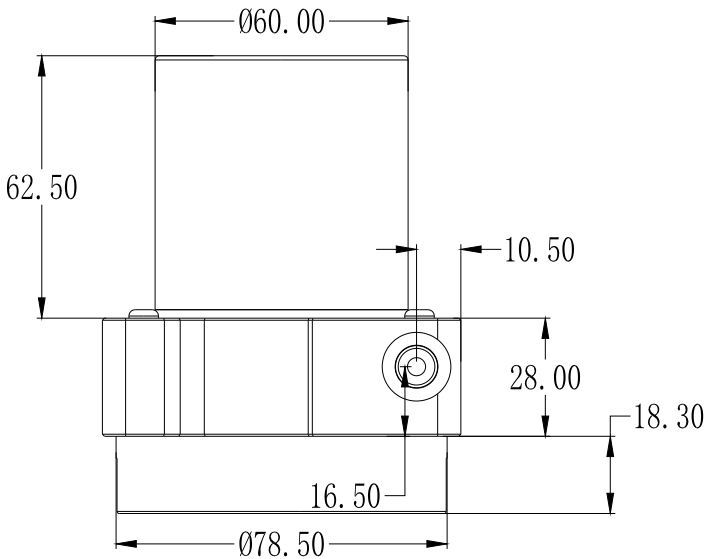
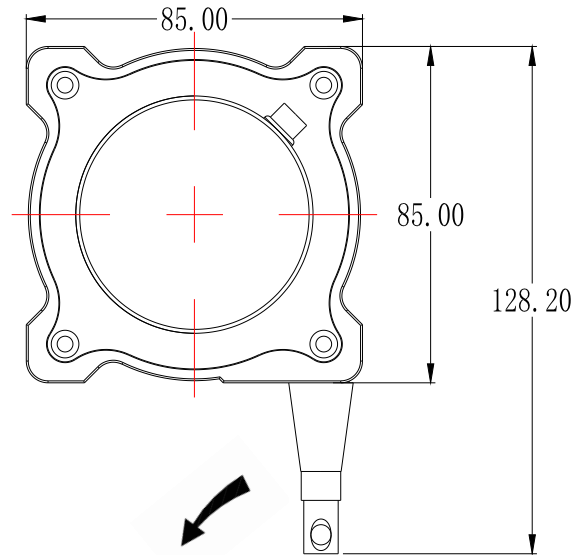
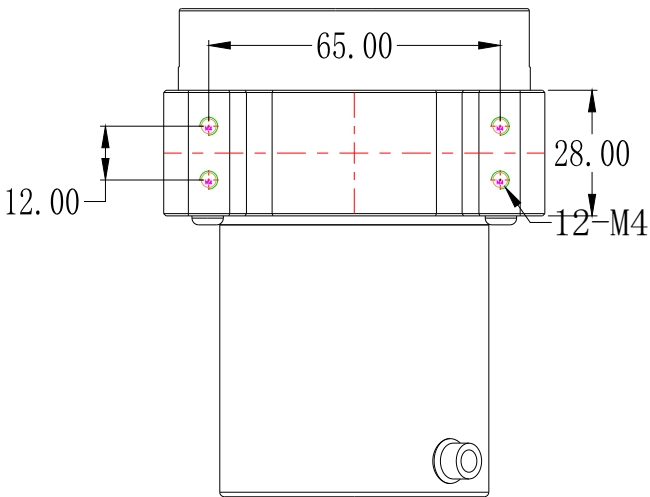
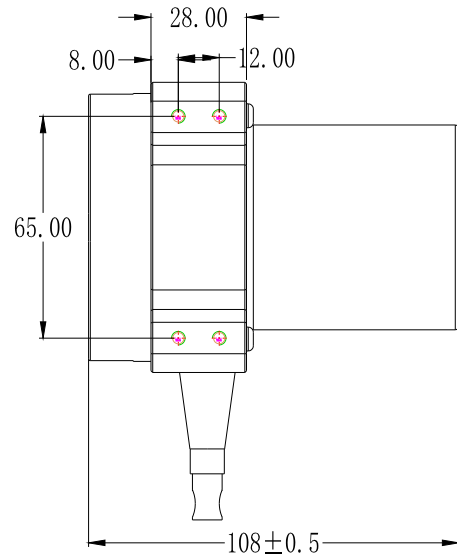

默认拉绳头尺寸(线径0.8mm):

Default rope head size(Wire diameter 0.8mm):

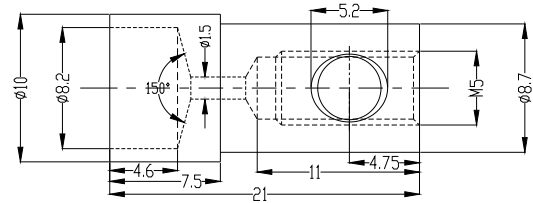

可选拉绳头尺寸(线径1.5mm):

Optional rope head size (Wire diameter 1.5mm):

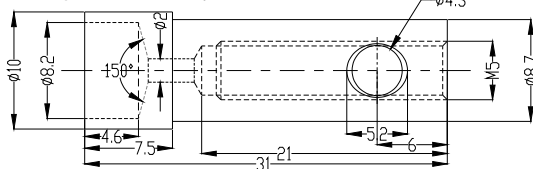

# WEP系列拉绳位移传感器

## WEP Series Rope Displacement Sensor

### 产品实物图 Physical Products Pictures

#### WEP-S



#### WEP-M



### 产品概述 Overview

WEP-S/M系列拉绳位移传感器，又称拉绳编码器，拉绳尺，拉线尺，拉线编码器，拉绳位移传感器，是直线位移传感器在结构上的精巧集成，充分结合了角度传感器和直线位移传感器的优点，成为一款结构紧凑、测量行程长、安装空间尺寸小、具有高精度测量的优良传感器。WEP-S/M系列拉绳位移传感器系列产品具有很大的选择空间，行程从100mm至2000mm不等，具有模拟电流信号A2：4-20mA电流输出二线制，电流信号A3：4-20mA电流输出三线制，电流信号A4：4-20mA电流输出四线制；模拟电压信号V1：0-5V，V2：0-10V，脉冲信号P：A、B、Z相数字输出，RS485数字信号输出。满足大行程、高精度各种信号需求。可应用于裂缝测量监测，桥梁测量监测，仓储位置定位，水库大坝保护，闸门开度控制，压力机械等方面。

The WEP-S/M series cable displacement sensor, also known as cable encoder, cable ruler, cable ruler, cable encoder, and cable displacement sensor, is a sophisticated integration of linear displacement sensors in structure, fully combining the advantages of angle sensors and linear displacement sensors. It has become an excellent sensor with compact structure, long measurement stroke, small installation space size, and high-precision measurement. The WEP-S/M series cable displacement sensor series products have a large selection space, with travel ranging from 100mm to 2000mm. It has a two wire system for analog current signal A2: 4-20mA current output, a three wire system for current signal A3: 4-20mA current output, and a four wire system for current signal A4: 4-20mA current output; Simulated voltage signals V1: 0-5V, V2: 0-10V, pulse signals P: A, B, Z-phase digital output, RS485 digital signal output. Meet various signal requirements for long travel and high precision. It can be applied to crack measurement and monitoring, bridge measurement and monitoring, warehouse location positioning, reservoir dam protection, gate opening control, pressure machinery and other aspects.

## 性能参数 Performance Parameter

### ⚡ 电气指标 Electrical Specifications

型号 Model	WEP-S/WEP-M拉绳位移传感器 WEP-S/WEP-M Rope displacement sensor		
重复性精度 Repeatability accuracy	±0.02%FS	输入电阻值 Input Resistance value	5kΩ ± 10%FS, 10kΩ ± 10%FS
保护等级 Protection level	IP65 (只限外壳) IP65 (Shell only)	储存温度 Storage temperature	-20°C ~ +80°C
震动 Vibrate	10Hz~2000Hz	功率 Power	70°C时1W (行程500mm), 70°C时2W (行程1000mm) 1W at 70°C (travel 500mm), 2W at 70°C (travel 1000mm)
传感器 Sensor	1. 绕线式多圈电位器; 2. 光栅式多圈编码器; 3. 磁感应(磁电)多圈位置传感器 1. Wire wound multi turn potentiometer; 2. Raster type multi turn encoder; 3. Magnetic induction (magneto electric) multi turn position sensor		
可选输出信号 Optional output signal	电位计输出 (DC5-10V), 电流/电压/RS485信号输出 (DC12-24V), 脉冲信号输出 (DC5-30V) Potentiometer output (DC5-10V), current/voltage/RS485 signal output (DC12-24V), pulse signal output (DC5-30V)		
工作温度 Operation temperature	-20°C ~ +75°C (低温状态下, 需保持无结晶状态; 涂抹防冻液最低工作温度可达-35°C; 脉冲输出工作温度为-10°C ~ 65°C) -20°C ~ +75°C (at low temperature, it should be kept in a non-crystalline state; The minimum working temperature of applying antifreeze can reach -35°C; Pulse output operating temperature is -10°C ~ 65°C)		

### ⚡ 性能指标 Performance Index

型号 Model	WEP-S拉绳位移传感器 (100mm-1000mm量程) WEP-S Rope displacement sensor (100mm-1000mm range)	
重量 Weight	≤ 600g	
拉力 Pulling	< 600g	
线性精度 Linear accuracy	600mm以下 ± 0.25%FS, 600mm以上 ± 0.1%FS Below 600mm ± 0.25% FS, above 600mm ± 0.1% FS	
线径规格 Wire diameter specification	直径0.8mm的多股不锈钢钢丝SUS316材质, 外层为尼龙涂层, 负载16kg 0.8mm diameter multi strand stainless steel wire SUS316 material, with an outer layer of nylon coating and a load of 16kg	
最大往复速度 Maximum reciprocating speed	500mm/秒 500mm/second	

型号 Model	WEP-M拉绳位移传感器 (1000mm-2000mm量程) WEP-M Rope displacement sensor (1000mm-2000mm range)	
重量 Weight	≤ 1000g	
拉力 Pulling	(行程0-1250mm) 600g; (行程超过1500) 最大1000g (Travel 0-1250mm) 600g; (Travel over 1500) Maximum 1000g	
线性精度 Linear accuracy	600mm以下 ± 0.25%FS, 600mm以上 ± 0.1%FS Below 600mm ± 0.25% FS, above 600mm ± 0.1% FS	
线径规格 Wire diameter specification	直径0.8mm/1.5mm的多股不锈钢钢丝SUS316材质, 外层为尼龙涂层 SUS316 multi stranded stainless steel wire with a diameter of 0.8mm/1.5mm, with an outer layer of nylon coating	
最大往复速度 Maximum reciprocating speed	1000mm/秒 1000mm/second	

产品尺寸图 Product Dimension Diagram

WEP-S

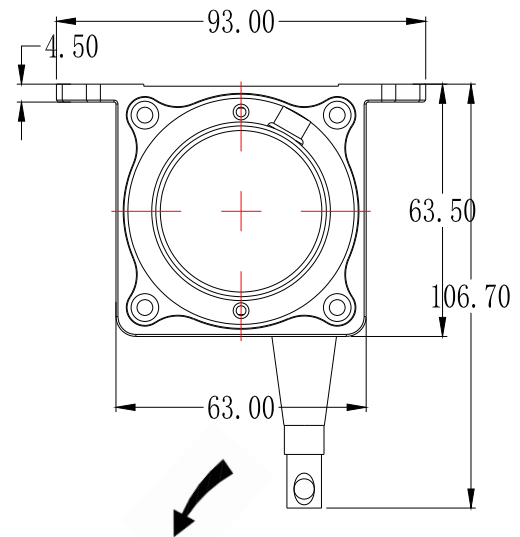
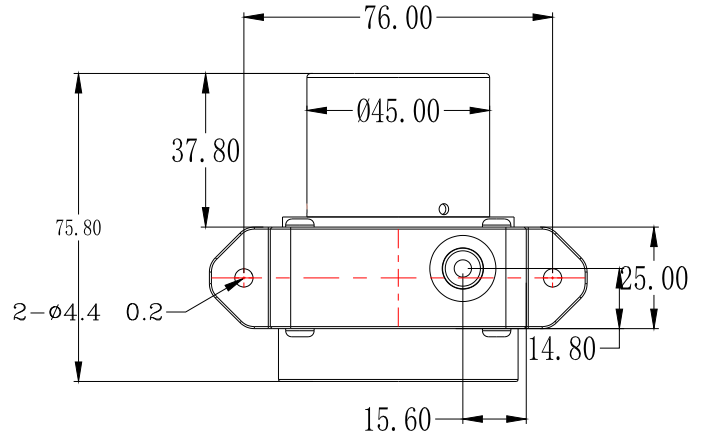
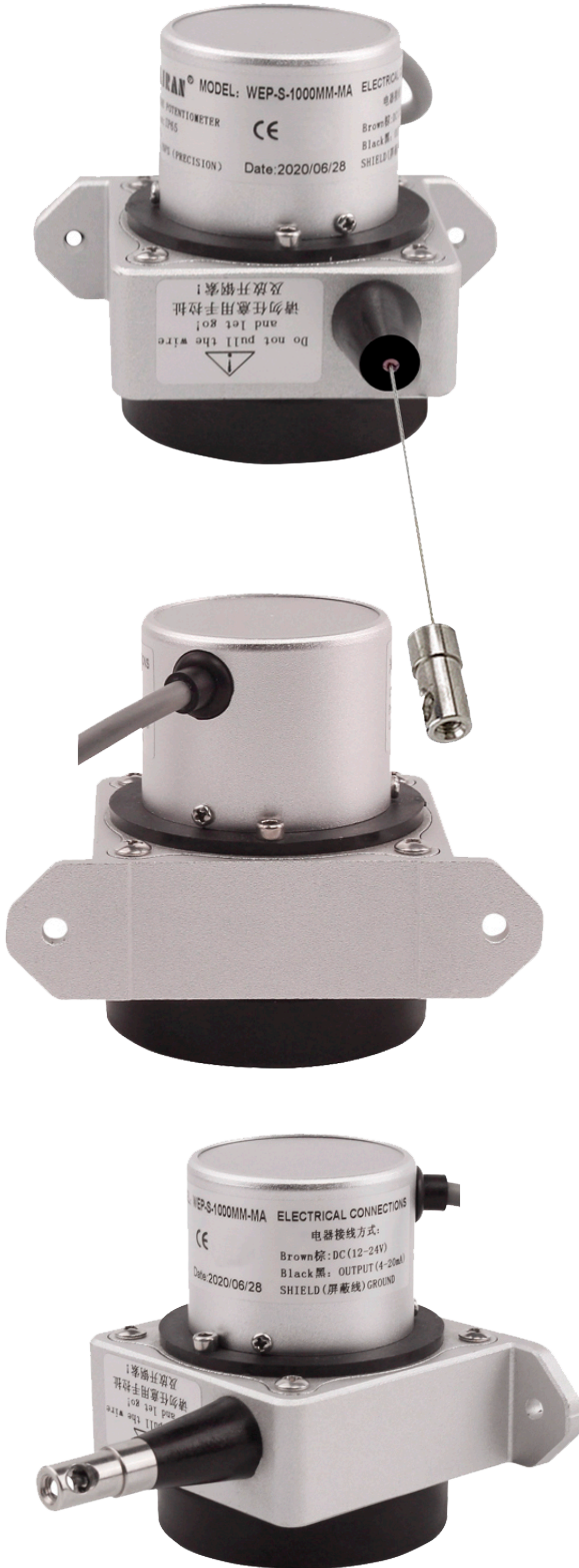

默认拉绳头尺寸(线径0.8mm):

Default rope head size(Wire diameter 0.8mm):

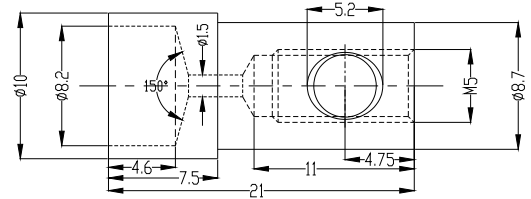

可选拉绳头尺寸(线径1.5mm):

Optional rope head size (Wire diameter 1.5mm):

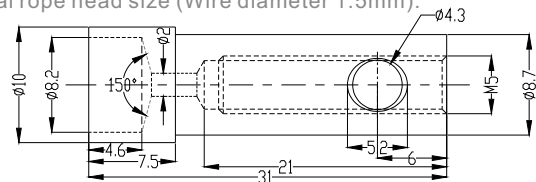



WEP-M

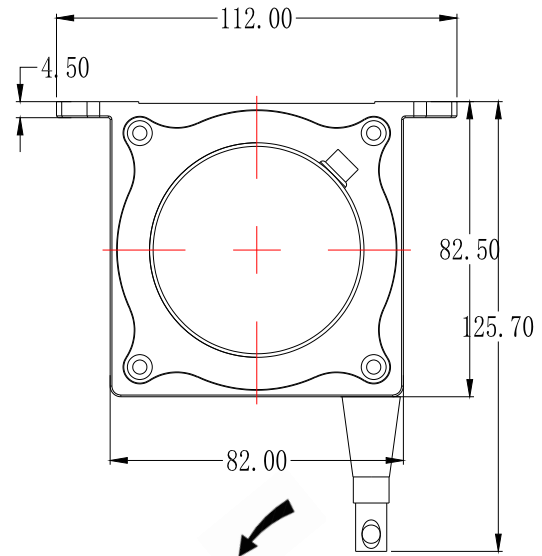
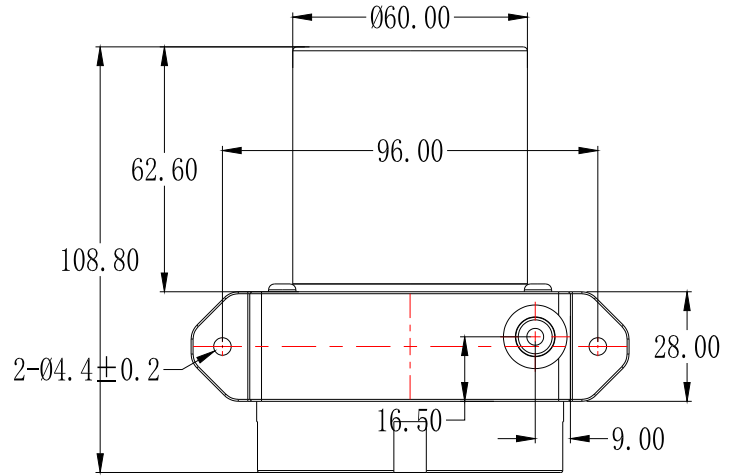

默认拉绳头尺寸(线径0.8mm):

Default rope head size(Wire diameter 0.8mm):

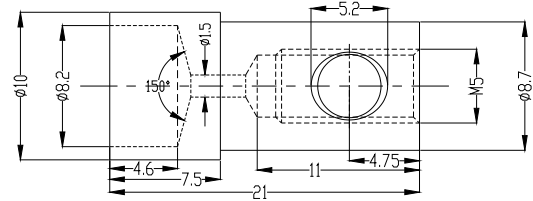

可选拉绳头尺寸(线径1.5mm):

Optional rope head size (Wire diameter 1.5mm):

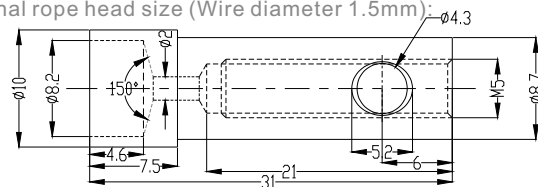

# WS-S拉绳位移传感器

## WS-S Rope Displacement Sensor

### 产品实物图 Physical Products Pictures



### 产品概述 Overview

WS-S拉绳式位移传感器，又称拉绳尺，拉线尺，拉线式位移传感器，拉绳位移传感器，是直线位移传感器在结构上的精巧集成，充分结合了角度传感器和直线位移传感器的优点，成为一款结构紧凑、测量行程长、安装空间尺寸小、具有高精度测量的优良传感器。WS-S拉绳式位移传感器系列产品具有很大的选择空间，行程从100mm至1000mm不等，具有模拟电流信号A2：4-20mA电流输出二线制，电流信号A3：4-20mA电流输出三线制，电流信号A4：4-20mA电流输出四线制；模拟电压信号V1：0-5V，V2：0-10V和RS485数字信号输出。满足大行程、高精度各种信号需求。全防护外壳为铝合金材质，更加美观大方，拉绳可倾斜45°往外拉出，且不影响线性精度及其重复性。

The WEP-S/M series cable displacement sensor, also known as cable encoder, cable ruler, cable ruler, cable encoder, and cable displacement sensor, is a sophisticated integration of linear displacement sensors in structure, fully combining the advantages of angle sensors and linear displacement sensors. It has become an excellent sensor with compact structure, long measurement stroke, small installation space size, and high-precision measurement. The WEP-S/M series cable displacement sensor series products have a large selection space, with travel ranging from 100mm to 2000mm. It has a two wire system for analog current signal A2: 4-20mA current output, a three wire system for current signal A3: 4-20mA current output, and a four wire system for current signal A4: 4-20mA current output; Simulated voltage signals V1: 0-5V, V2: 0-10V, pulse signals P: A, B, Z-phase digital output, RS485 digital signal output. Meet various signal requirements for long travel and high precision. It can be applied to crack measurement and monitoring, bridge measurement and monitoring, warehouse location positioning, reservoir dam protection, gate opening control, pressure machinery and other aspects.

性能参数 Performance Parameter

⚡ 电气指标 Electrical Specifications

WS-S拉绳位移传感器 (100mm-800mm量程) WS-S Rope displacement sensor (100mm-800mm range)	
重复性精度 Repeatability accuracy	±0.02%FS
拉力 Pulling	<600g
重量 Weight	≤600g
传感器 Sensor	绕线式多圈电位器 Wire wound multi turn potentiometer
功率 Power	70°C时1W (行程500mm), 70°C时2W (行程1000mm) 1W at 70 °C (travel 500mm), 2W at 70 °C (travel 1000mm)
震动 Vibrate	10Hz~2000Hz
线性精度 Linear accuracy	600mm以下±0.25%FS, 600mm以上±0.1%FS Below 600mm ± 0.25% FS, above 600mm ± 0.1% FS
线径规格 Wire diameter specification	直径0.8mm的多股不锈钢钢丝SUS316材质, 外层为尼龙涂层, 负载16kg 0.8mm diameter multi strand stainless steel wire SUS316 material, with an outer layer of nylon coating and a load of 16kg
最大往复速度 Maximum reciprocating speed	500mm/秒 500mm/second
输入电阻值 Input resistance value	5kΩ ± 10%FS, 10kΩ ± 10%FS
储存温度 Storage temperature	-20°C~+80°C
保护等级 Protection level	IP65 (只限外壳) IP65 (Shell only)
可选输出信号 Optional output signal	电位计输出 (DC5-10V), 电流/电压/RS485信号输出 (DC12-24V) Potentiometer output (DC5-10V), current/voltage/RS485 signal output (DC12-24V)
工作温度 Operation temperature	-20°C~+75°C (低温状态下, 需保持无结晶状态; 涂抹防冻液最低工作温度可达-35°C; 脉冲输出工作温度为-10°C~65°C) -20°C~+75°C (at low temperature, it should be kept in a non-crystalline state; The minimum working temperature of applying antifreeze can reach -35°C; Pulse output operating temperature is -10°C~65°C)

产品尺寸图 Product Dimension Diagram

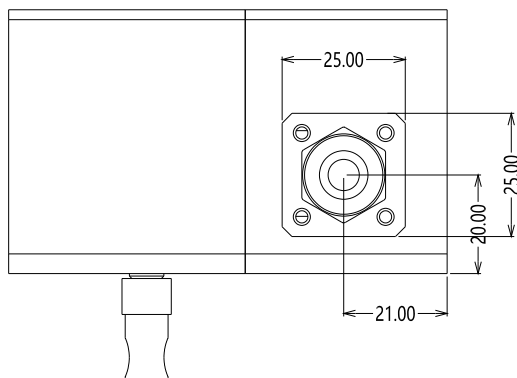
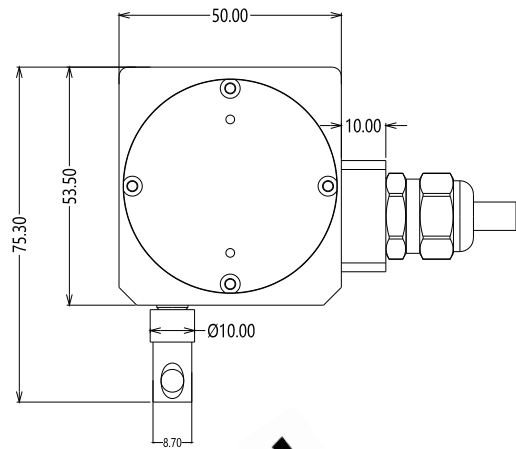
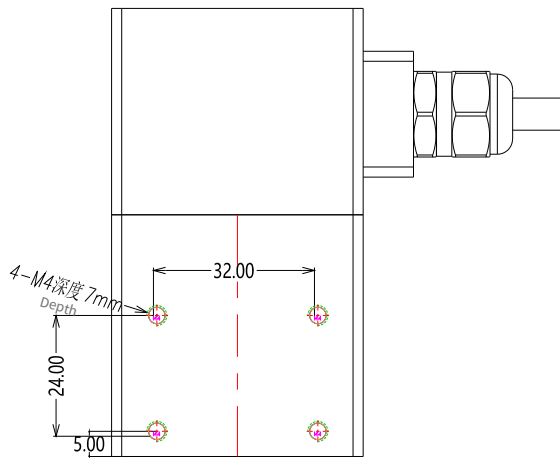
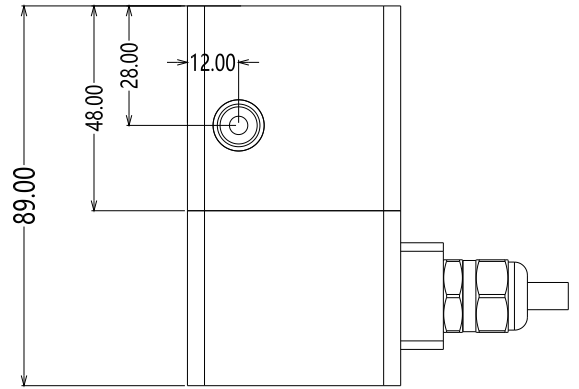

默认拉绳头尺寸(线径0.8mm):

Default rope head size(Wire diameter 0.8mm):

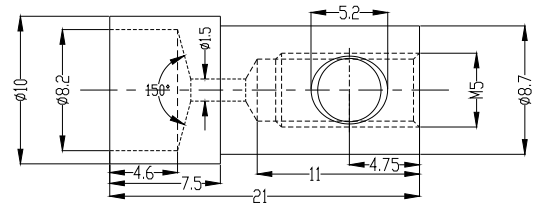

可选拉绳头尺寸(线径1.5mm):

Optional rope head size (Wire diameter 1.5mm):

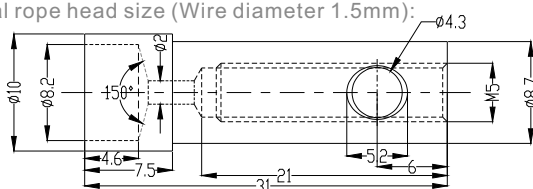

# MDS-S 拉绳位移传感器

## MDS-S Rope Displacement Sensor

### 产品实物图 Physical Products Pictures



### 产品概述 Overview

MDS-S拉绳式位移传感器，又称拉绳编码器，拉绳尺，拉线尺，拉线编码器，拉线位移传感器，是直线位移传感器在结构上的精巧集成，充分结合了角度传感器和直线位移传感器的优点，成为一款结构紧凑、测量行程长、安装空间尺寸小、具有高精度测量的优良传感器。该系列产品具有很大的选择空间，行程从100mm至1200mm不等，具有模拟电流信号A2：4-20mA电流输出二线制，电流信号A3：4-20mA电流输出三线制，电流信号A4：4-20mA电流输出四线制；模拟电压信号V1：0-5V，V2：0-10V，脉冲信号P：A、B、Z相数字输出，RS485数字信号输出。满足大行程、高精度各种信号需求。

The WEP-S/M series cable displacement sensor, also known as cable encoder, cable ruler, cable ruler, cable encoder, and cable displacement sensor, is a sophisticated integration of linear displacement sensors in structure, fully combining the advantages of angle sensors and linear displacement sensors. It has become an excellent sensor with compact structure, long measurement stroke, small installation space size, and high-precision measurement. The WEP-S/M series cable displacement sensor series products have a large selection space, with travel ranging from 100mm to 2000mm. It has a two wire system for analog current signal A2: 4-20mA current output, a three wire system for current signal A3: 4-20mA current output, and a four wire system for current signal A4: 4-20mA current output; Simulated voltage signals V1: 0-5V, V2: 0-10V, pulse signals P: A, B, Z-phase digital output, RS485 digital signal output. Meet various signal requirements for long travel and high precision. It can be applied to crack measurement and monitoring, bridge measurement and monitoring, warehouse location positioning, reservoir dam protection, gate opening control, pressure machinery and other aspects.



## 性能参数 Performance Parameter

### ⚡ 电气指标 Electrical Specifications

型号 Model	MDS-R/MDS-S-MA/MDS-S-V1/MDS-S-V2拉绳位移传感器 MDS-R/MDS-S-MA/MDS-S-V1/MDS-S-V2 Rope displacement sensor
重复性精度 Repeatability accuracy	±0.02%FS
拉力 Pulling	<600g
重量 Weight	≤600g
传感器 Sensor	1. 绕线式多圈电位器；2. 光栅式多圈编码器；3. 磁感应(磁电)多圈位置传感器 1. Wire wound multi turn potentiometer; 2. Raster type multi turn encoder; 3. Magnetic induction (magneto electric) multi turn position sensor
震动 Vibrate	10Hz-2000Hz
线性精度 Linear accuracy	600mm以下±0.25%FS, 600mm以上±0.1%FS Below 600mm ± 0.25% FS, above 600mm ± 0.1% FS
线径规格 Wire diameter specification	直径0.8mm的多股不锈钢钢丝SUS316材质, 外层为尼龙涂层, 负载16kg 0.8mm diameter multi strand stainless steel wire SUS316 material, with an outer layer of nylon coating and a load of 16kg
最大往复速度 Maximum reciprocating speed	500mm/秒 500mm/second
储存温度 Storage temperature	-20°C~+80°C
保护等级 Protection level	IP65 (只限外壳) IP65 (Shell only)
工作温度 Operation temperature	-20°C~+75°C (低温状态下, 需保持无结晶状态; 涂抹防冻液最低工作温度可达-35°C; 脉冲输出工作温度为-10°C~65°C) -20°C~+75°C (at low temperature, it should be kept in a non-crystalline state; The minimum working temperature of applying antifreeze can reach -35°C; Pulse output operating temperature is -10°C~65°C)

### ⚡ 性能指标 Performance Index

型号 Model	MDS-R	输入电压 Input voltage	5/10V DC
功率 Power	70°C时1W(行程500mm), 70°C时2W(行程1000mm) 1W at 70 °C (travel 500mm), 2W at 70 °C (travel 1000mm)	输出电阻值 Output resistance value	5kΩ ± 10%FS, 10kΩ ± 10%FS

型号 Model	MDS-S-mA	输入电流 Input Current	最大25mA Maximum 25mA
输出信号模式 Output signal mode	4-20mA (3线制)、(2线制) 4-20mA (3-wire system), (2-wire system)	工作电压 Working voltage	DC12-24VDC

 性能指标 Performance Index

型号 Model	MDS-S-P		
检测方式 Detection	增量型 Incremental	输出波形 Output waveform	脉冲方波 Pulse square wave
测量行程 Measuring stroke	(100mm-1200mm)之间量程任意可选 Any range between 100mm and 1200mm can be selected	解析 Analysis	1, 0.5, 0.2, 0.1, 0.04
精度 Accuracy	$\pm 0.05\%FS$ , $\pm 1$ 计算 $\pm 0.05\% FS, \pm 1$ calculation	输出相 Output phase	AB相或ABZ相 AB phase or ABZ phase
电路特性 Circuit characteristics	电压型, 电源型, 推挽式, 差动式 Voltage type, power type, push-pull type, differential type	工作电压 Working voltage	12-24VDC, 固定5VDC 12-24VDC, fixed 5VDC
消耗电流 Consumption current	$\leq 30mA$	最大响应频率 Maximum response frequency	300kHz~500kHz
寿命 Life	典型 $>1 \times 10^6$ 循环 Typical $>1 \times 10^6$ cycles	波形上下时间 Waveform up and down time	$\leq 2$
保护等级 Protection level	IP65 (仅限外壳) IP65 (Shell only)	起动转轴 Start shaft	最大400g Maximum 400g
最大往复速度 Maximum reciprocating speed	1000mm/秒 1000mm/second	震动 Vibrate	10g (10 $\pm$ 1500Hz)
极性保护 Polarity protection	防反向保护(不使用5V) Anti reverse protection (not using 5V)	冲击 Impact	20g/11ms
重量 Weight	$< 450g$	拉力 Pulling	最大700g Maximum 700g
工作温度 Operation temperature	-10 $^{\circ}C$ ~60 $^{\circ}C$ (低温状态下, 需保持无结晶状态) -10 $^{\circ}C$ ~60 $^{\circ}C$ (at low temperatures, it is necessary to maintain a crystalline state)	储存温度 Storage temperature	-20 $^{\circ}C$ ~+80 $^{\circ}C$
线径规格 Wire diameter specification	直径0.8mm的多股不锈钢钢丝SUS316材质, 外层为尼龙涂层; 负载为23kg Multi strand stainless steel wire SUS316 with a diameter of 0.8mm, with an outer layer coated with nylon; Load is 23kg		
相位差 Phase difference	A, B相位差90 $^{\circ}C$ +45 $^{\circ}C$ (T/4+T/8), Z相T+T/2 a. B phase difference 90 $^{\circ}C$ +45 $^{\circ}C$ (T/4+T/8), Z phase T+T/2		

型号 Model	MDS-S-V1/MDS-S-V2		
输出信号模式 Output signal mode	0-5VDC 或 0-10VDC 0-5VDC or 0-10VDC	供应电流 Supply current	最大10mA Maximum 10mA
供应电压 Supply voltage	0-5VDC输出电压为10-24VDC 0-10VDC输出电压为12-24VDC 0-5VDC output voltage is 10-24VDC, 0-10VDC output voltage is 12-24VDC		

产品尺寸图 Product Dimension Diagram

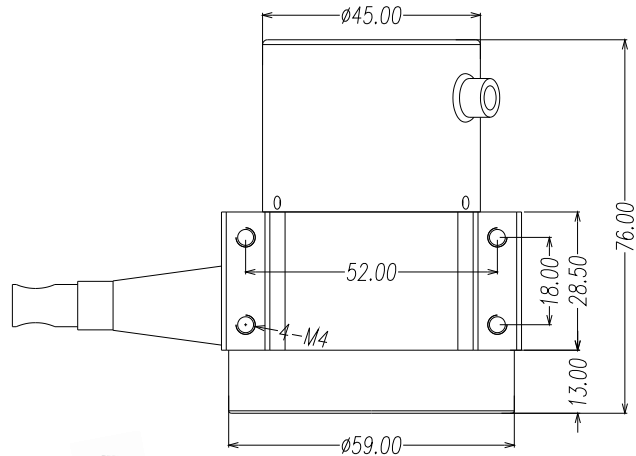
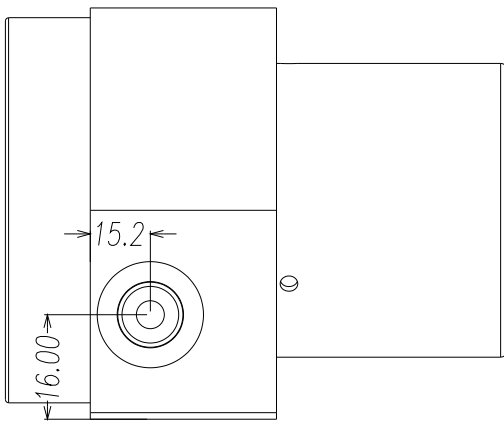

默认拉绳头尺寸 (线径0.8mm):

Default rope head size (Wire diameter 0.8mm):

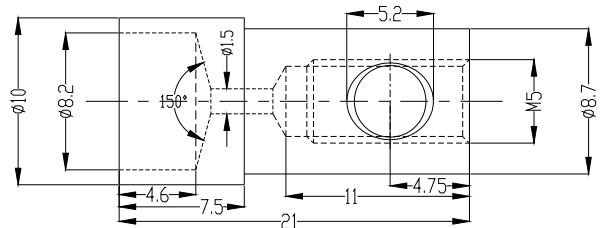

可选拉绳头尺寸 (线径1.5mm):

Optional rope head size (Wire diameter 1.5mm):

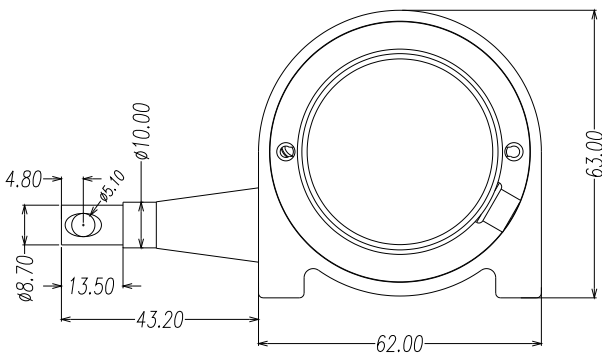
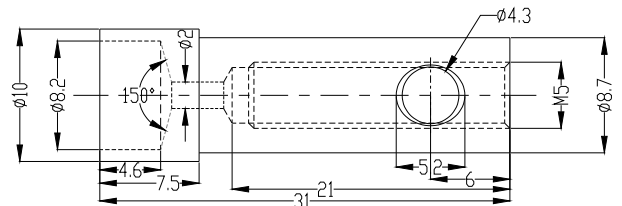

# 防护罩系列拉绳位移传感器

## Protective Cover Series Rope Displacement Sensor

### 产品实物及尺寸图 Product Physical And Dimensional Drawings

#### 塑料防护罩 (M机座) Plastic Protective Cover (M base)

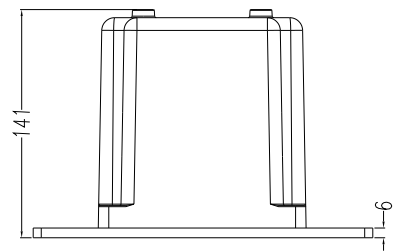
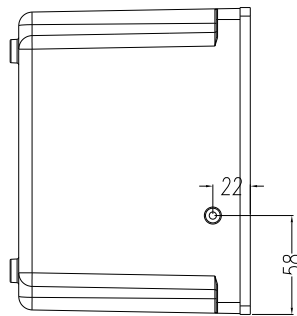
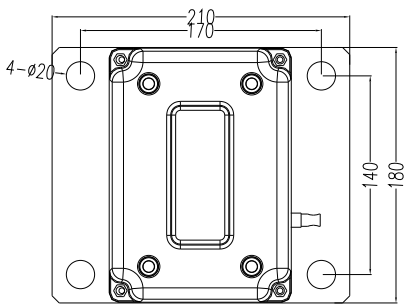
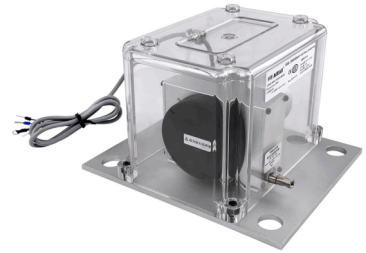

#### 铝合金防护罩 (M机座) Aluminum Alloy Protective Cover (M base)

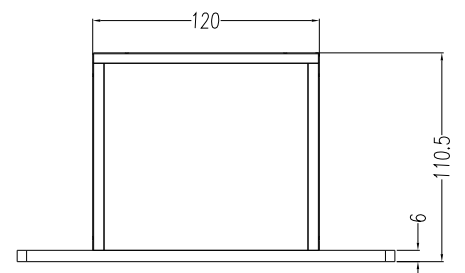
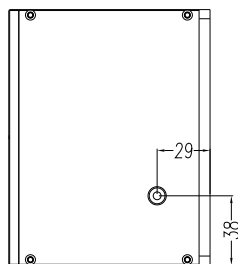
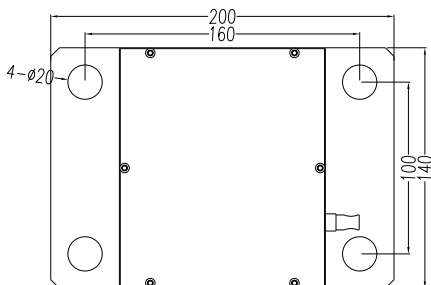

# MPSFS2系列防水型拉绳位移传感器

## MPSFS2 Series Waterproof Rope Displacement Sensor

### 产品实物图 Physical Products Pictures

#### MPSFS2-S

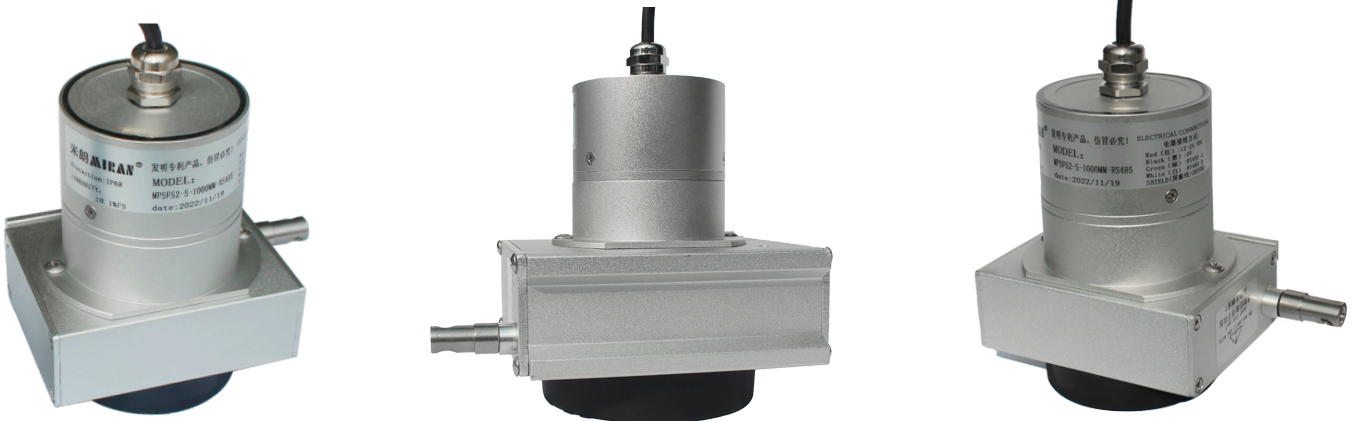

#### MPSFS2-M

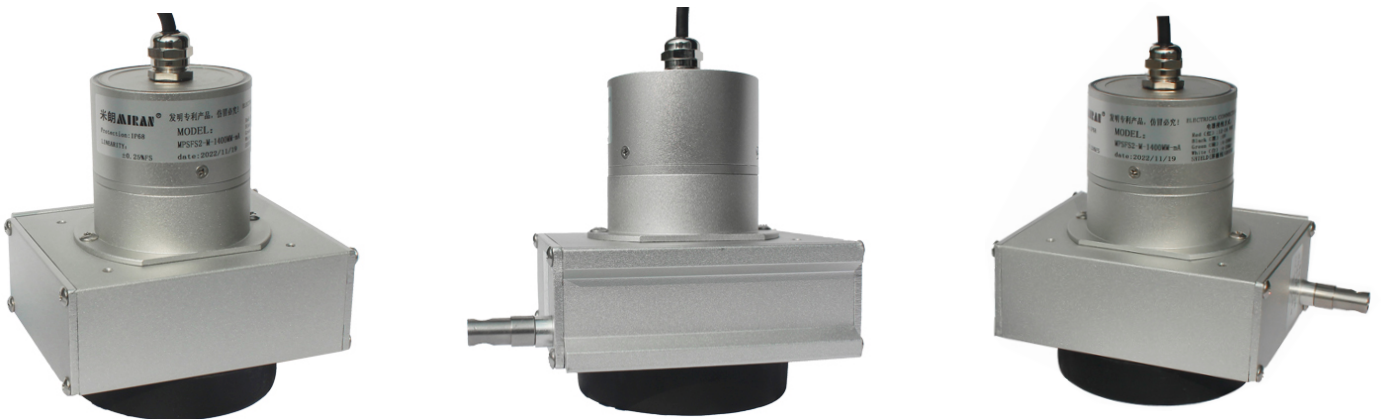

#### MPSFS2-L





## MPSFS2-XL

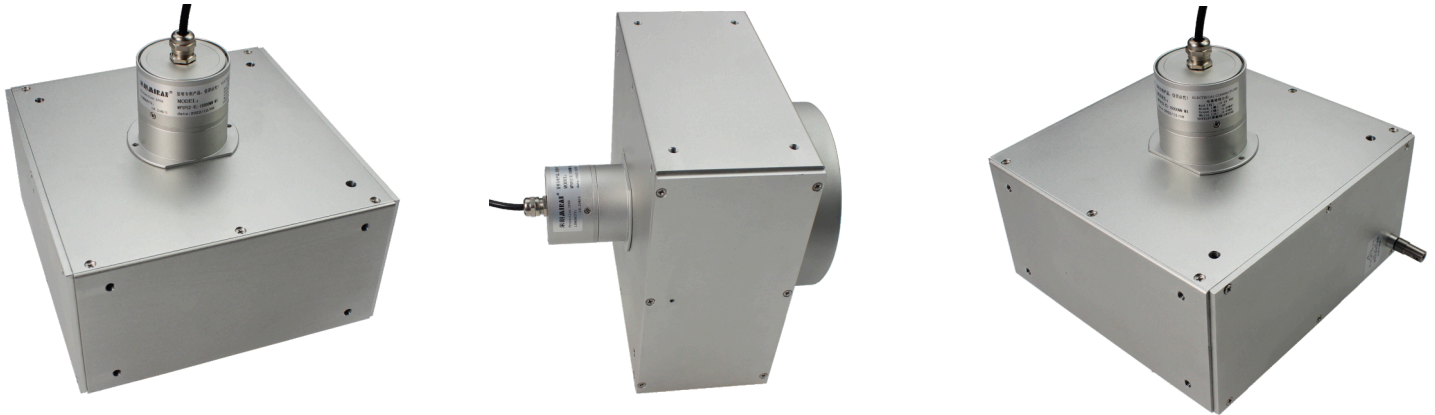

## 产品概述 Overview

MPSFS2防水型(磁感应)拉绳位移传感器，又称拉绳编码器拉绳尺，拉线尺，拉线编码器，拉绳位移传感器。采用米朗公司自主研发多圈磁感应绝对值编码器，内部使用高强度灌封胶封装，从而保证磁感应绝对值编码器能够在水下长期正常工作。MPSFS2-S防水绝对值型拉绳位移传感器零部件均采用在水内永不生锈材料制作，如：不锈钢发条和拉绳，铝合金外壳和线轮，塑料发条外壳，陶瓷轴承。S机座和M机座系列产品往复运动的瞬间加速不可超过1米/秒；L机座和XL机座系列产品往复运动的瞬间加速不可超过0.5米/秒；否则将导致钢索断裂。MPSFS2-S量程范围：100mm-1300mm，MPSFS2-M量程范围：1000mm-4000mm，MPSFS2-L量程范围：4500mm-10000mm，MPSFS2-XL量程范围：11000mm-35000mm(其他行程可定制)。

MPSFS2 waterproof (magnetic induction) rope displacement sensor, also known as rope encoder rope ruler, rope ruler, rope encoder, rope displacement sensor. We use the independently developed multi coil magnetic induction absolute value encoder by Mirang Company, which is encapsulated with high-strength sealing glue internally to ensure that the magnetic induction absolute value encoder can work normally underwater for a long time. The MPSFS2-S waterproof absolute value pull rope displacement sensor components are all made of materials that will never rust in water, such as stainless steel spring and pull rope, aluminum alloy shell and wire wheel, plastic spring shell, and ceramic bearings. The instantaneous acceleration of the reciprocating motion of the S and M base series products shall not exceed 1 meter/second; The instantaneous acceleration of the reciprocating motion of the L base and XL base series products shall not exceed 0.5 meters per second; Otherwise, it will cause the steel cable to break. MPSFS2-S range: 100mm-1300mm, MPSFS2-M range: 1000mm-4000mm, MPSFS2-L range: 4500mm-10000mm, MPSFS2-XL range: 11000mm-35000mm (other travel options can be customized).

## 性能参数 Performance Parameter

### ⚡ 电气指标 Electrical Specifications

MPSFS2-S/M/L/XL防水型拉绳位移传感器 PSFS2-S/M/L/XL Waterproof and explosion-proof rope displacement sensor	
重复性精度 Repeatability accuracy	±0.05%FS
线径规格 Wire diameter specification	直径0.8mm或1.5mm的多股不锈钢钢丝SUS316材质，外层为尼龙涂层； SUS316 multi stranded stainless steel wire with a diameter of 0.8mm or 1.5mm, with an outer layer of nylon coating;
震动 Vibrate	10Hz-2000Hz
线性精度 Linear accuracy	±0.25%FS
工作环境温度 Ambient temperature	-10°C~60°C (低温需保持无结晶状态) -10 °C~60 °C (low temperature needs to be maintained in a crystalline state)
防护等级 Protection grade	IP68
测量行程 Measuring stroke	S: 100mm-1300mm M: 1000mm-4000mm L: 4500mm-10000mm XL: 11000mm-35000mm (其他行程可定制) (Other itineraries can be customized)

### ⚡ 性能指标 Performance Index

电源电压 Supply voltage	DC12V~DC24V (电压/电流/RS485) 波动5%以下 DC12V~DC24V (voltage/current/RS485) fluctuation below 5%
可选输出信号 Optional output signal	电压输出型: 0-5V, 0-10V, 电流输出型: 4-20mA, 数字信号输出型: RS485, SSI Voltage output type: 0-5V, 0-10V, current output type: 4-20mA, digital signal output type: RS485, SSI (以上均为绝对位置输出型) (All of the above are absolute position output types)
分辨率 Resolution ratio	模拟量输出: 16位; 数字量输出: 12位 Analog output: 16 bits; Digital output: 12 bits
电源电压VCC消耗电流 Power supply voltage VCC consumes current	40mA (不含突变情况) 40mA (excluding sudden changes)

产品尺寸图 Product Dimension Diagram

MPSFS2-S

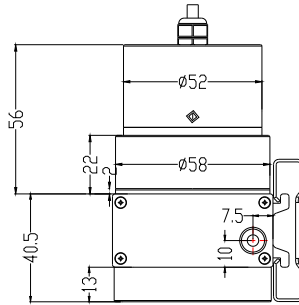

默认拉绳头尺寸(线径0.8mm):

Default rope head size(Wire diameter 0.8mm):

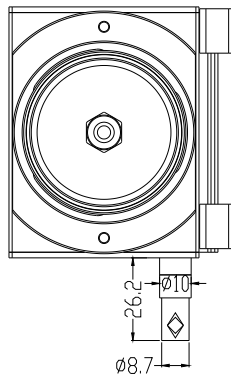
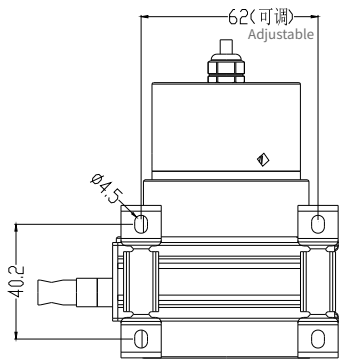
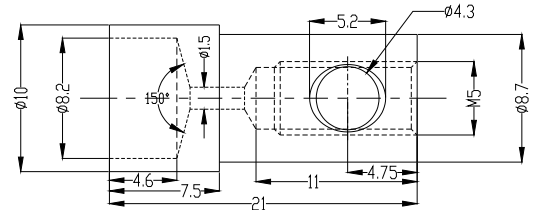

可选拉绳头尺寸(线径1.5mm):

Optional rope head size (Wire diameter 1.5mm):

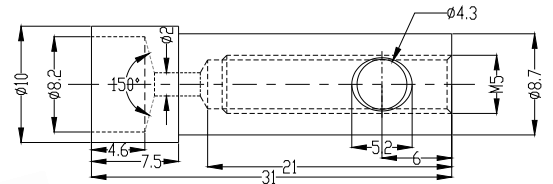

MPSFS2-M

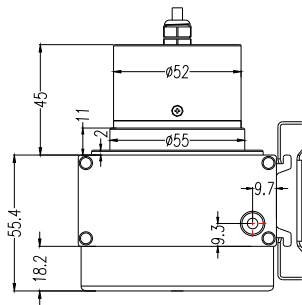

默认拉绳头尺寸(线径0.8mm):

Default rope head size(Wire diameter 0.8mm):

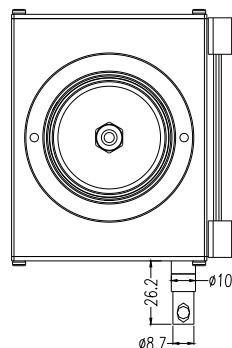
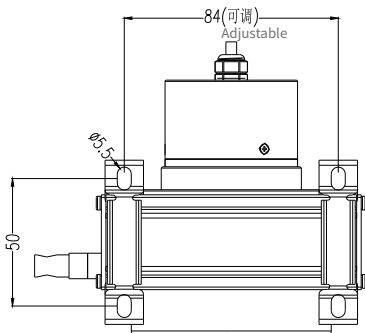
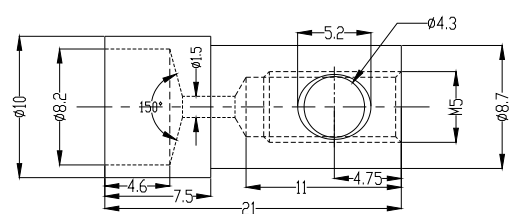

可选拉绳头尺寸(线径1.5mm):

Optional rope head size (Wire diameter 1.5mm):

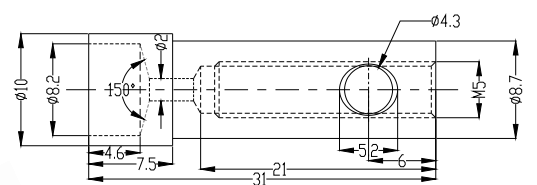

产品尺寸图 Product Dimension Diagram

MPSFS2-L

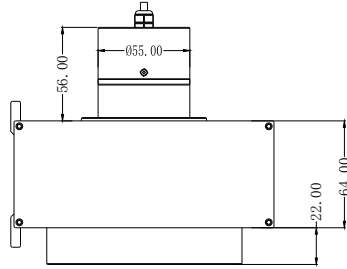
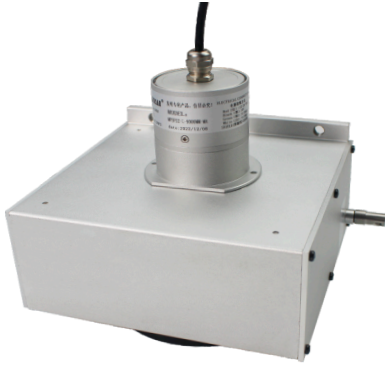

默认拉绳头尺寸(线径0.8mm):

Default rope head size(Wire diameter 0.8mm):

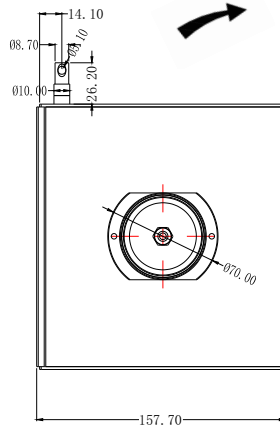
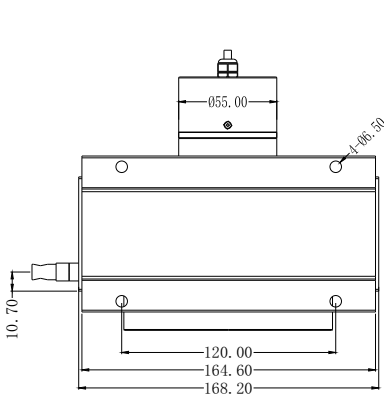
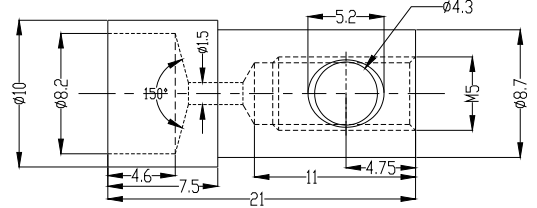

可选拉绳头尺寸(线径1.5mm):

Optional rope head size (Wire diameter 1.5mm):

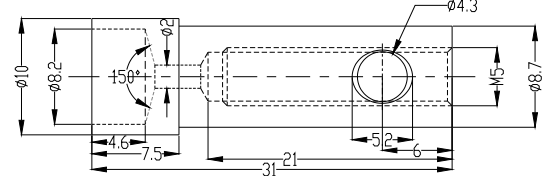

MPSFS2-XL

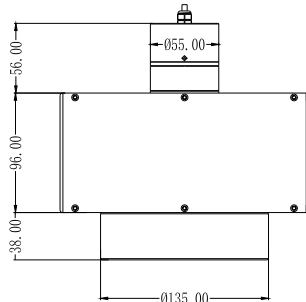
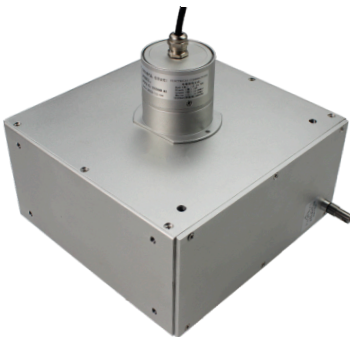

默认拉绳头尺寸(线径0.8mm):

Default rope head size(Wire diameter 0.8mm):

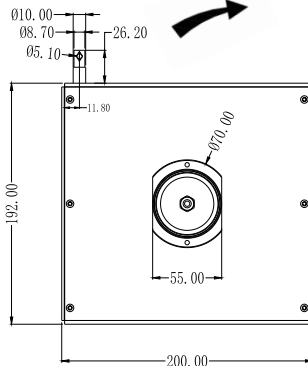
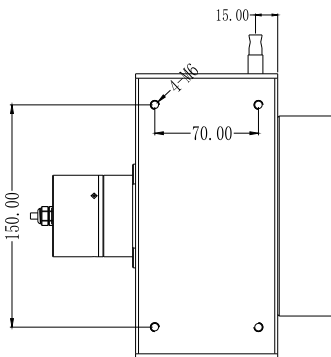
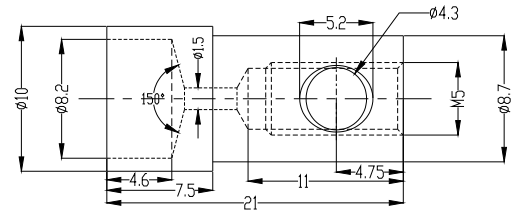

可选拉绳头尺寸(线径1.5mm):

Optional rope head size (Wire diameter 1.5mm):

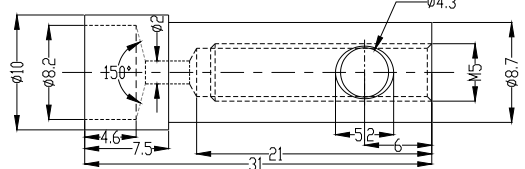

# MPSZFS2-ZM/ZL重载型防水拉绳位移传感器

MPSZFS2-ZM/ZL Heavy duty waterproof rope displacement sensor

产品实物图 Physical Products Pictures

MPSZFS2-ZM

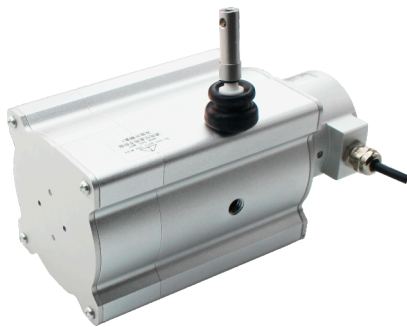
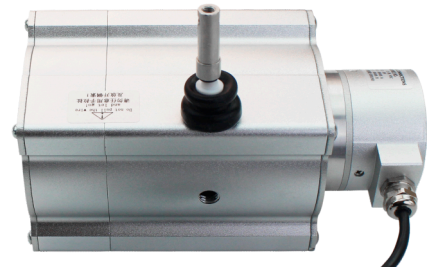
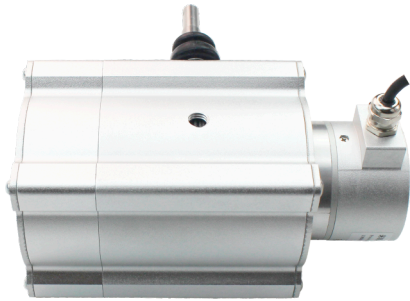

MPSZFS2-ZL





## 产品概述 Overview

重载型防水拉绳位移传感器，又称拉绳编码器，拉绳尺，拉线尺，拉线编码器，拉线位移传感器，该传感器采用米朗公司自主研发多圈磁感应绝对值编码器，内部使用高强度灌封胶封装，从而保证磁感应绝对值编码器能够在水下长期正常工作。

重载型防水拉绳位移传感器在结构上的精巧集成，充分结合了角度传感器和直线位移传感器的优点，成为一款测量行程长、安装简单、具有高精度测量的绝对值拉线位移传感器。

Heavy-duty waterproof pull rope displacement sensor, also known as pull rope encoder, pull rope ruler, pull wire ruler, pull wire encoder, pull wire displacement sensor, the sensor adopts the multi-circle magnetic induction absolute encoder independently developed by Milang company, the internal use of high-strength pot-sealing adhesive package, so as to ensure that the magnetic induction absolute encoder can work normally under water for a long time. The compact integration of heavy-duty waterproof cable displacement sensor in structure fully combines the advantages of Angle sensor and linear displacement sensor, and becomes an absolute alignment value displacement sensor with long measuring stroke, simple installation and high precision measurement.

## 性能参数 Performance Parameter

量程 Range	ZM: 100mm-4000mm; ZL: 4500mm-35000mm(其他行程可定制) ZM:100mm-4000mm;4500mm-35000mm (Other itineraries can be customized)
电源电压 Supply voltage	DC12V~DC24V (电压/电流/RS485) 波动5%以下 DC12V~DC24V (Voltage/Current/RS485)Fluctuation below 5%
电源电压VCC消耗电流 Power supply voltage VCC consumes current	40mA (不含突变情况) (Excluding mutation situations)
线性精度 Linear accuracy	±0.25%FS
重复性 Repeatability	±0.05%FS
分辨率 Resolution ratio	模拟量16位，数字量12位 Analog 16 bits, digital 12 bits
线径规格 Range	直径1.5mm的多股不锈钢钢丝SUS316材质，外层为尼龙涂层; SUS316 multi stranded stainless steel wire with a diameter of 1.5mm, with an outer layer of nylon coating;
防雷击/防浪涌 Lightning/surge protection	有 (GB/T 17626.5-2019) Yes (GB/T 17626.5-2019)
防静电 Anti-static	有 (GB/T 17626.2) Yes (GB/T 17626.2)
防腐蚀 Anti-corrosion	盐雾测试24H，6级 Salt spray test 24 hours, level 6
抗震动 Vibration resistance	10Hz to 2000Hz, 5g
防护等级 Protection grade	IP68
工作环境温度 Ambient Temperature	-10°C~60°C低温状态下，需保持无结晶状态 At low temperatures ranging from -10°C to 60°C, it is necessary to maintain a non crystalline state
输出信号 Output signal	模拟量输出信号: 0-5V, 0-10V, 4-20mA, 数字量输出信号: RS485, SSI, 脉冲信号A/B/Z Analog output signal: 0-5V, 0-10V, 4-20mA, digital output signal: RS485, SSI, pulse signal A/B/Z (以上均为绝对位置输出型) (All of the above are absolute position output types)

产品尺寸图 Product Dimension Diagram

MPSZFS2-ZM

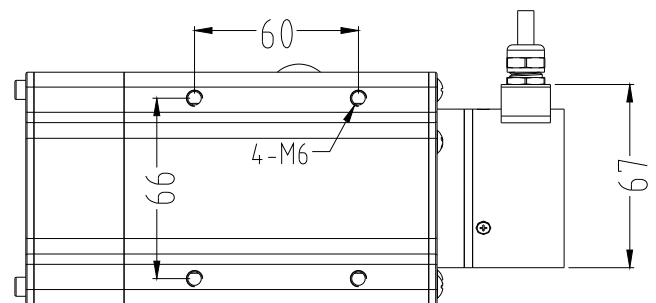
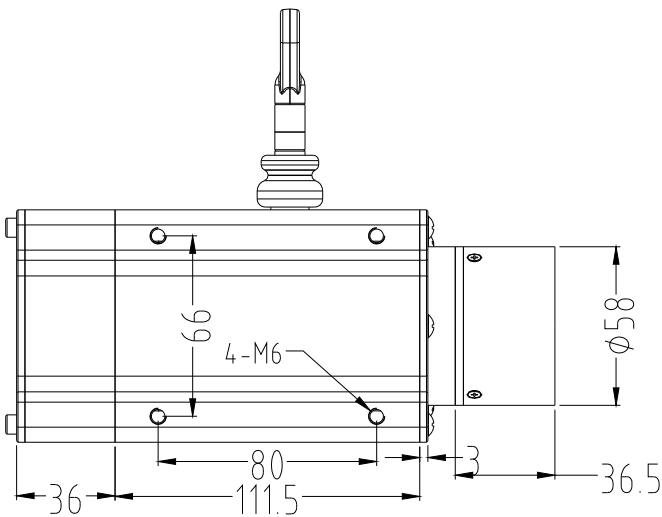
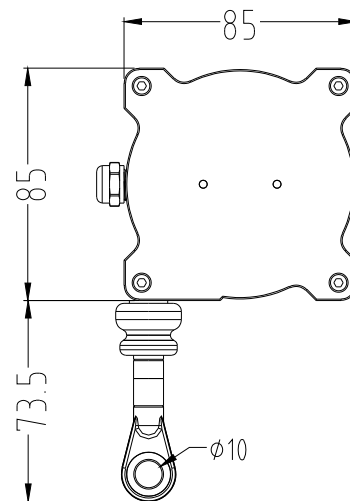
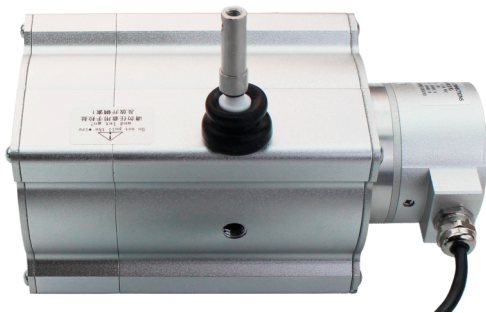
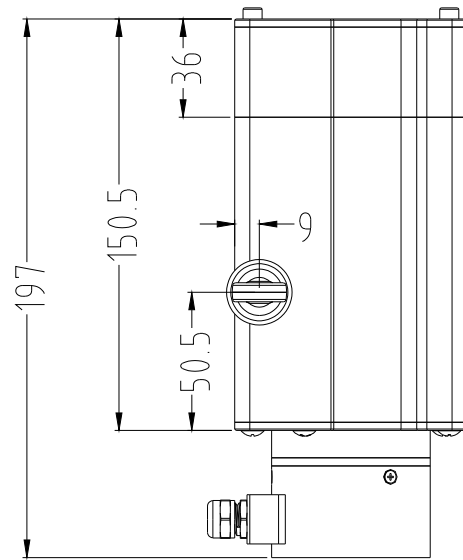

注：  
安装时请利用底部6个固定螺丝孔(任意三面，拉头面不可固定)，依现场及机器安装空间设施需要,直接安装或另加保护或其他机械使用。

Note:  
When installing, please use the bottom 6 fixed screw holes (any three sides, the pull surface cannot be fixed), and according to the needs of the site and machine installation space facilities, install directly or add additional protection or use other machinery.

产品尺寸图 Product Dimension Diagram

MPSZFS2-ZL

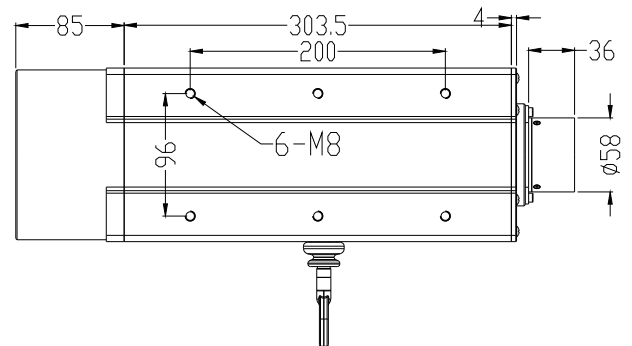
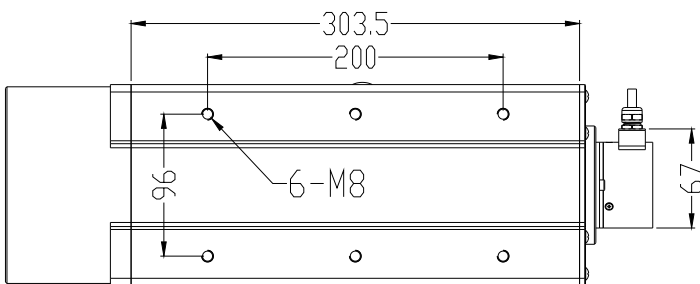
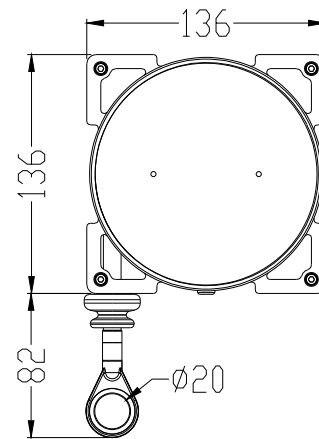
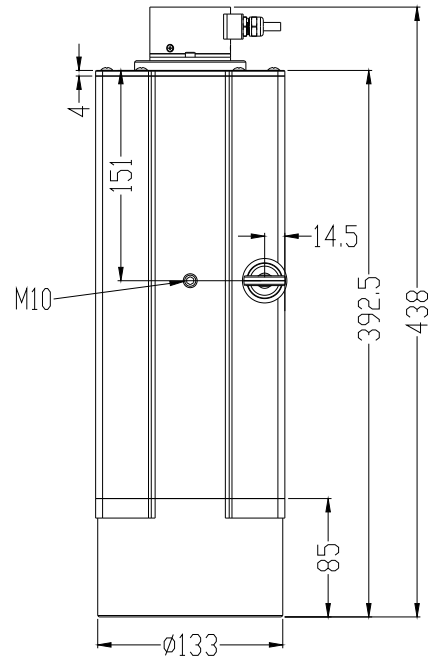

注：  
 安装时请利用底部6个固定螺丝孔(任意三面，拉头面不可固定)，依现场及机器安装空间设施需要,直接安装或另加保护或其他机械使用。

Note:  
 When installing, please use the bottom 6 fixed screw holes (any three sides, the pull surface cannot be fixed), and according to the needs of the site and machine installation space facilities, install directly or add additional protection or use other machinery.

# MFB-MPSFS2 防水防爆型拉绳位移传感器

## MFB-MPSFS2 Waterproof Rope Displacement Sensor

### 产品实物图 Physical Products Pictures

#### MFB-MPSFS2-S



#### MFB-MPSFS2-M

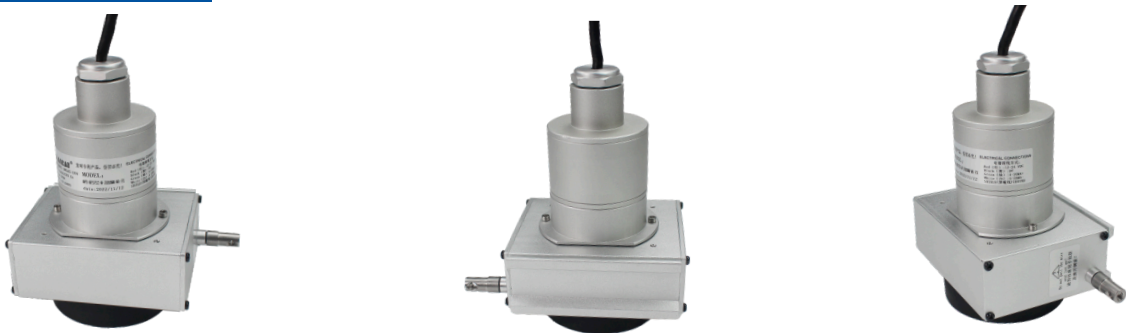

#### MFB-MPSFS2-L



#### MFB-MPSFS2-XL

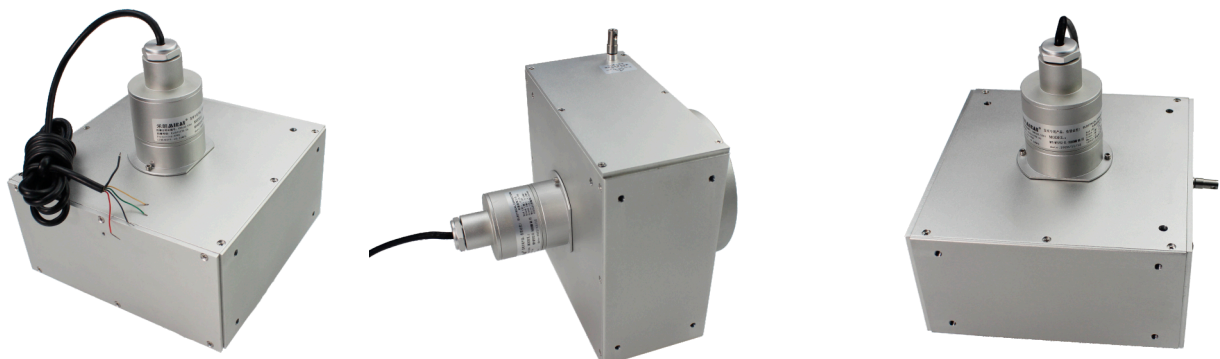

## 产品概述 Overview

MFB-MPSFS2防水防爆型(磁感应)拉绳位移传感器, 又称拉绳编码器拉绳尺, 拉线尺, 拉线编码器, 拉绳位移传感器。采用米朗公司自主研发多圈磁感应绝对值编码器, 内部使用高强度灌密封胶封装, 从而保证磁感应绝对值编码器能够在水下长期正常工作。MFB-MPSFS2-S防水防爆绝对值型拉线式位移传感器零部件均采用在水内永不生锈材料制作, 如: 不锈钢发条和拉绳, 铝合金外壳和线轮, 塑料发条外壳, 陶瓷轴承。S机座和M机座系列产品往复运动的瞬间加速不可超过1米/秒; L机座和XL机座系列产品往复运动的瞬间加速不可超过0.5米/秒; 否则将导致钢索断裂。MFB-MPSFS2-S量程范围: 100mm-1300mm; MPSFS2-M量程范围: 1000mm-4000mm; MPSFS2-L量程范围: 4500mm-10000mm; MPSFS2-XL量程范围: 11000mm-35000mm (其他行程可定制)。防爆证书位于本彩页第50页。

MFB-MPSFS2 waterproof and explosion-proof (magnetic induction) rope displacement sensor, also known as rope encoder rope ruler, rope ruler, rope encoder, rope displacement sensor. We use the independently developed multi coil magnetic induction absolute value encoder by Mirang Company, which is encapsulated with high-strength sealing glue internally to ensure that the magnetic induction absolute value encoder can work normally underwater for a long time. The MFB-MPSFS2-S waterproof and explosion-proof absolute value pull type displacement sensor components are all made of materials that will never rust in water, such as stainless steel spring and pull rope, aluminum alloy shell and wire wheel, plastic spring shell, and ceramic bearings. The instantaneous acceleration of the reciprocating motion of the S and M base series products shall not exceed 1 meter/second; The instantaneous acceleration of the reciprocating motion of the L base and XL base series products shall not exceed 0.5 meters per second; Otherwise, it will cause the steel cable to break. MFB-MPSFS2-S range: 100mm-1300mm, MPSFS2-M range: 1000mm-4000mm, MPSFS2-L range: 4500mm-10000mm, MPSFS2-XL range: 11000mm-35000mm (other travel options can be customized). The explosion-proof certificate is located on page 50 of this color page.

## 性能参数 Performance Parameter

### ⚡ 电气指标 Electrical Specifications

型号 Model	MFB-MPSFS2-S/M/L/XL防水防爆型拉绳传感器 MFB-MPSFS2-S/M/L/XL Waterproof and explosion-proof rope sensor		
重复性精度 Repeatability accuracy	±0.05%FS	分辨率 Resolution ratio	模拟量输出: 16位; 数字量输出: 12位 Analog output: 16 bits; Digital output: 12 bits
线性精度 Linear accuracy	±0.25%FS	工作环境温度 Ambient temperature	-10°C~60°C (低温需保持无结晶状态) -10°C~60°C (low temperature needs to be maintained in a crystalline state)
震动 Vibrate	10Hz-2000Hz	防护等级 Protection grade	IP68
电源电压VCC消耗电流 Power supply voltage VCC consumes current	40mA (不含突变情况) 40mA (excluding sudden changes)	防爆标志 Explosion proof sign	Ex db IIC T6 Gb
测量行程 Measuring stroke	S: 100mm-1300mm M: 1000mm-4000mm L: 4500mm-10000mm XL: 11000mm-35000mm (其他行程可定制) S: 100mm-1300mm M: 1000mm-4000mm L: 4500mm-10000mm XL: 11000mm-35000mm (Other itineraries can be customized)		
电源电压 Supply voltage	DC12V~DC24V (电压/电流/RS485) 波动5%以下 DC12V~DC24V (voltage/current/RS485) fluctuation below 5%		
线径规格 Wire diameter specification	直径0.8mm或1.5mm的多股不锈钢钢丝SUS316材质, 外层为尼龙涂层; SUS316 multi stranded stainless steel wire with a diameter of 0.8mm or 1.5mm, with an outer layer of nylon coating;		
可选输出信号 Optional output signal	电压输出型: 0-5V, 0-10V, 电流输出型: 4-20mA, 数字信号输出型: RS485, SS I Voltage output type: 0-5V, 0-10V, current output type: 4-20mA, digital signal output type: RS485, SS I (以上均为绝对位置输出型) (All of the above are absolute position output types)		



产品尺寸图 Product Dimension Diagram

MFB-MPSFS2-S

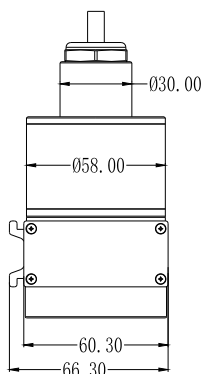

默认拉绳头尺寸(线径0.8mm):

Default rope head size (Wire diameter 0.8mm):

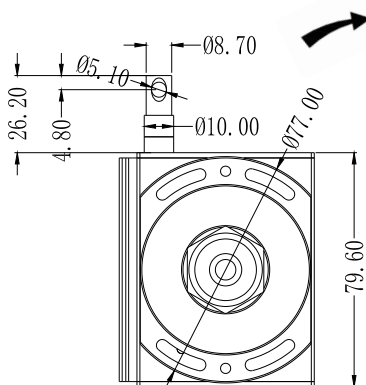
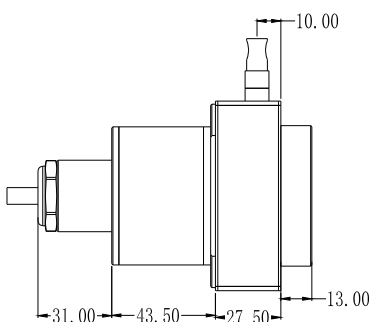
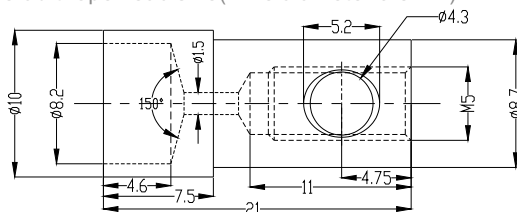

可选拉绳头尺寸(线径1.5mm):

Optional rope head size (Wire diameter 1.5mm):

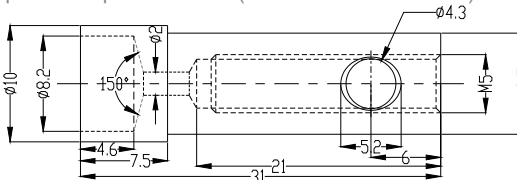

MFB-MPSFS2-M

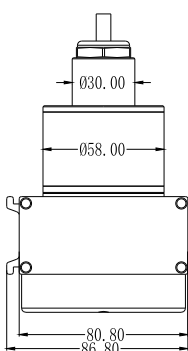

默认拉绳头尺寸(线径0.8mm):

Default rope head size (Wire diameter 0.8mm):

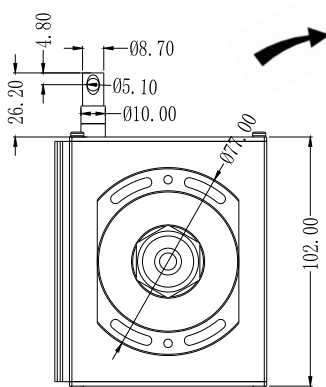
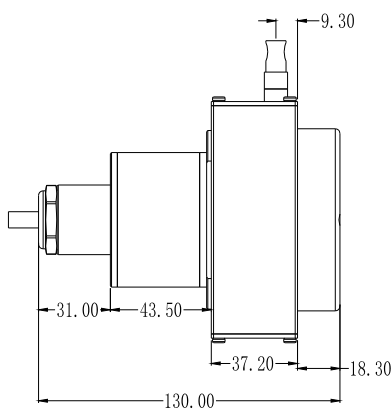
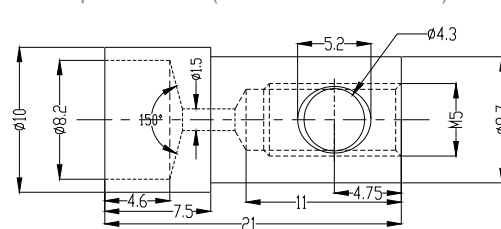

可选拉绳头尺寸(线径1.5mm):

Optional rope head size (Wire diameter 1.5mm):

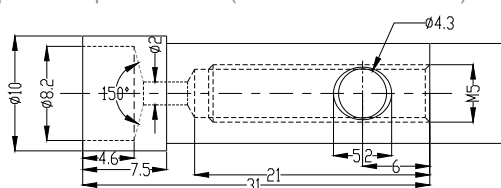

产品尺寸图 Product Dimension Diagram

MFB-MPSFS2-L

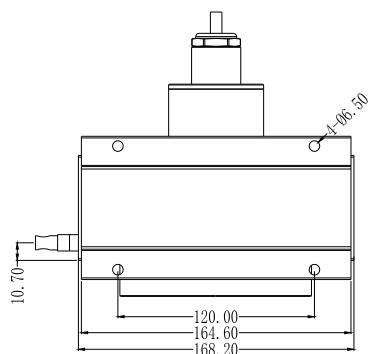
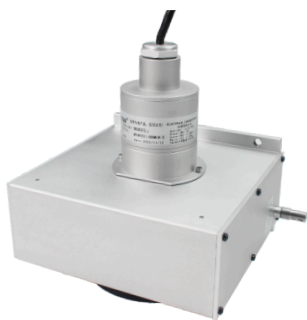

默认拉绳头尺寸(线径0.8mm):

Default rope head size (Wire diameter 0.8mm):

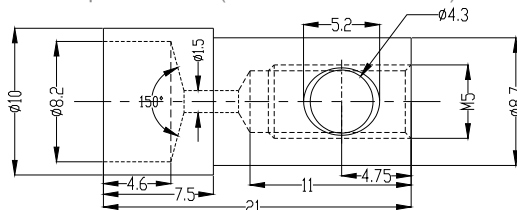

可选拉绳头尺寸(线径1.5mm):

Optional rope head size (Wire diameter 1.5mm):

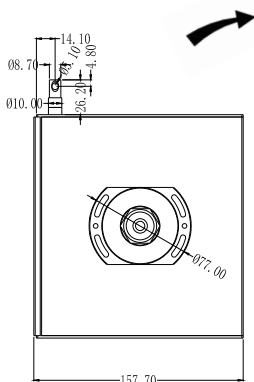
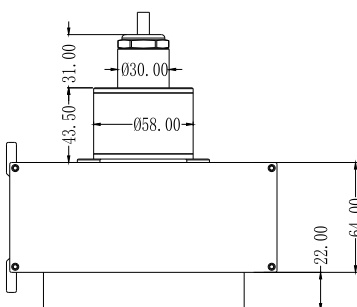
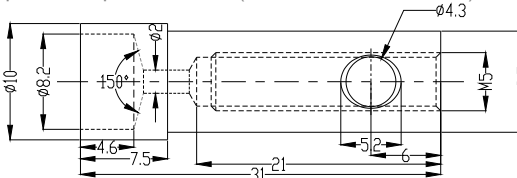

MFB-MPSFS2-XL

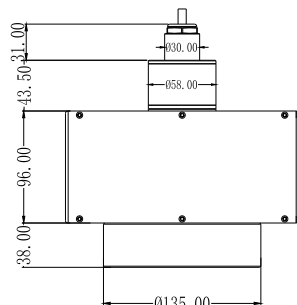
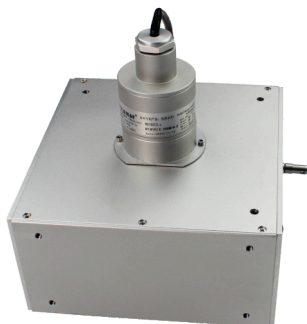

默认拉绳头尺寸(线径0.8mm):

Default rope head size (Wire diameter 0.8mm):

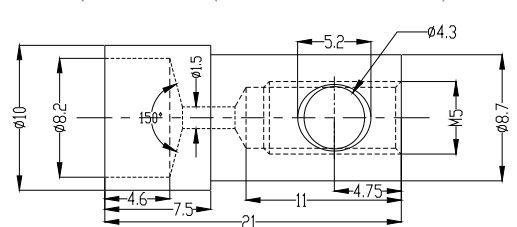

可选拉绳头尺寸(线径1.5mm):

Optional rope head size (Wire diameter 1.5mm):

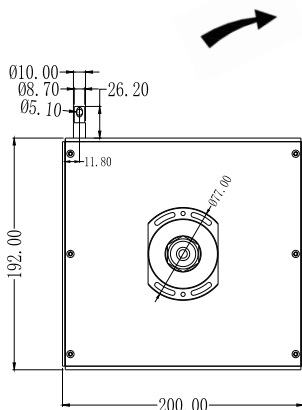
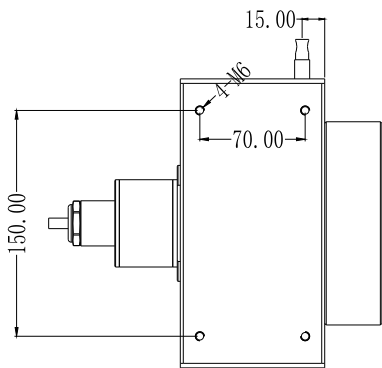
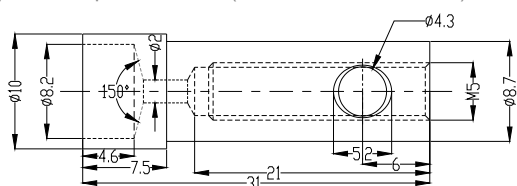



编号: CNEx22.5301

## 防爆合格证

制造单位 枣阳市米朗科技有限公司  
地址: 湖北省枣阳市南城霍庄村八组

产品名称 拉绳位移传感器

型号规格 MFB-MPSFS2 24VDC

防爆标志 Ex db IIC T6 Gb

产品标准 Q/ MLKJ02 -2022

总装图号 MFB-MPSFS2.00

经对上述产品图样及技术文件的审查和样品检验,确认符合下列标准:  
GB/T3836.1-2021 《爆炸性环境 第1部分:设备 通用要求》  
GB/T3836.2-2021 《爆炸性环境 第2部分:由隔爆外壳“d”保护的的设备》

记事:  
1.使用环境温度: -20℃ ~ +60℃。  
2.外壳防护等级: IP68(1m/2h)。

中心主任  颁发日期 2022年11月02日  
本证有效期 2022年11月02日至2027年11月01日



南阳防爆电气研究所  
国家防爆电气产品质量检验检测中心



注: 本证书仅对与证书文件和产品一致的产品有效。登录网站或关注公众号查询真伪 2559 6476 0664 5902  
地址: 中国河南省南阳市仲景北路20号  
邮编: 473008 电话: 0377-63258564 传真: 0377-63208175 网址: www.china-ex.com

公众号

荣誉证书 Certificate Of Honor

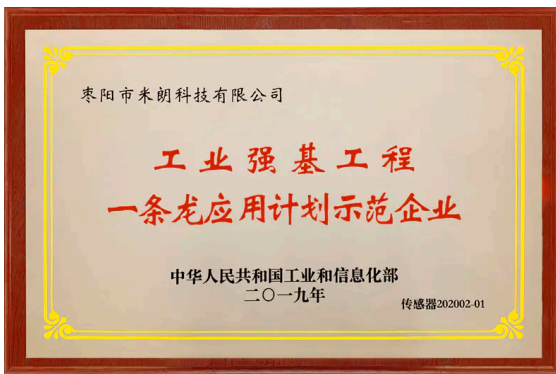

检测证书 Testing Certificate





应用领域 Application Area

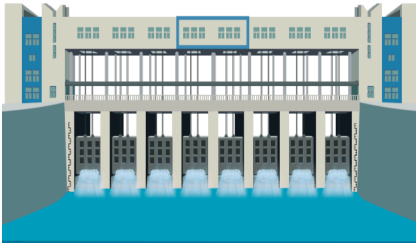

● 闸门开度控制  
Gate Opening Control



● 建筑健康监测  
Building Health Monitoring



● 液压机  
Hydraulic Press

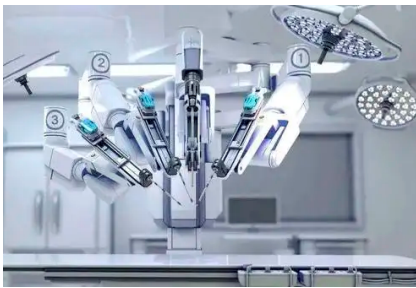

● 工业机器人  
Industrial Robots



● 纺织机械  
Textile Machinery



● 桥梁与大坝监测  
Bridge And Dam Monitoring



● 石油钻井设备  
Oil Drilling Equipment



● 空气压缩机  
Air Compressor



拉绳位移传感器应用场所极多,随着核心技术的发展,拉绳位移传感器得到越来越广泛的应用。

适合应用于工厂、山体、铁路、隧道、船业、机械、建筑业、医疗事业、桥梁铺设、水坝建设、汽车行业、核工业和航空航天事业等。

With the development of the core technology, the rope displacement sensor is used more and more widely. It is suitable for factories, mountains, railways, tunnels, ships, machinery, construction, medical industry, bridge laying, dam construction, automobile industry, nuclear industry and aerospace industry.





辐射全国 放眼世界

Radiate nationwide and look around the world

质量第一

Quality First

用户至上

User First

诚信为本

Honesty is the best policy

以技术创新为核心，以客户需求为导向

Centered on technological innovation and guided by customer needs

将致力于位移、物位、角度等测控领域

We will be committed to the measurement and control fields of displacement, level, angle, etc

为客户提供一站式解决方案的产品与服务

Provide customers with one-stop solutions for products and services

版权归深圳市米朗科技有限公司所有  
Copyright belongs to Shenzhen Miran Technology Co., Ltd

本选型样本如有变动，恕不另行通知，以最新版本为准  
This selection sample is subject to change without prior notice, and the latest version shall prevail

任何拷贝、复制、拍摄制作作为商业用途均属于侵权  
Any copy, reproduction, filming and production for commercial purposes is infringing

主要著作人：李工  
Main author: Engineer Li

2024年07月出品  
Produced in July 2024