

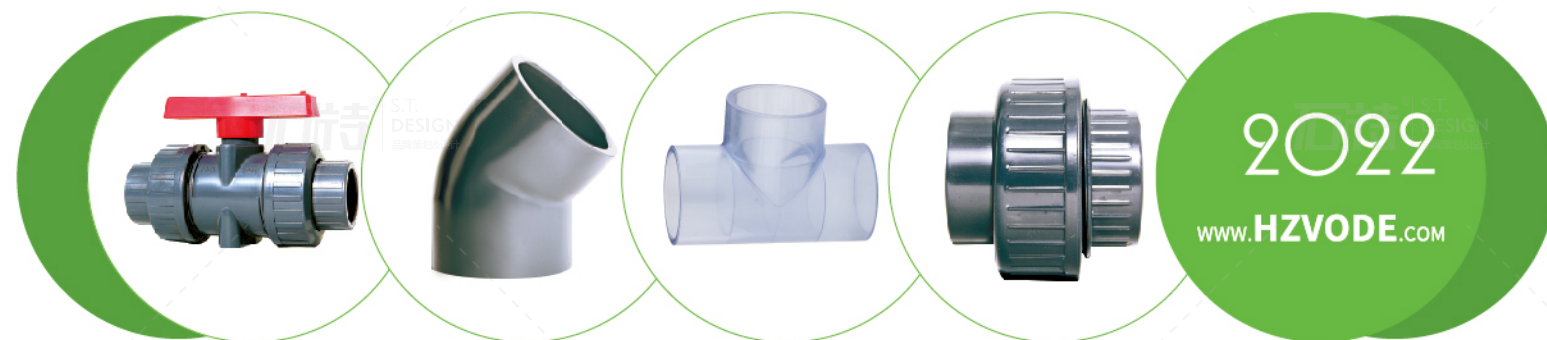

为全球提供一流的塑胶产品及服务
Provide top plastic products & service for all countries & regions



杭州沃德塑胶有限公司
HANGZHOU WORLD PLASTIC CO., LTD.



杭州沃德塑胶有限公司
HANGZHOU WORLD PLASTIC CO., LTD.

地址: 浙江省杭州市余杭区星桥北路66号

电话: 0571-88113226 88101095 89086366 传真: 0571-88113260

邮箱: hzvode@163.com 网址: www.hzvode.com

hzvode

■ 采用UPVC环保材质

- 塑料管材
- 管件
- 阀门
- 超滤膜壳
- 环保水处理

Contents 目录

01
企业简介

03
管件系列

13
阀门系列

17
透明管材系列

19
环保水处理配套系列

25
资料说明

27
耐化学腐蚀资料表

化工
—
水处理
—
生物
—
环保
—
医药
—
建筑
—
造纸
—
食品
—
消防
—
电力

COMPANY PROFILE

公司简介



杭州沃德塑胶有限公司是专业生产UPVC 塑料管材、管件、阀门、超滤膜壳、环保水处理等系列配套产品的企业。产品规格从D20到D400配套齐全，广泛应用于化工、水处理、生物、环保、医药、建筑、造纸、食品、消防、电力等行业。

公司技术力量雄厚，拥有一批专业的技术人员及研发团队，并与浙江大学及浙江工业大学等科研机构建立了密切的合作关系，产品采用先进的设备及优质的原料进行生产，严格按照ISO9001标准执行生产管理、品质控制，开发生产优质的沃德塑胶产品。

公司自创建以来一贯坚持“团结、求实、创新、高效”的企业发展方针，以“质量第一，信誉第一”为经营宗旨，以用户的满意是我们永恒追求为目标。参与世界竞争不断提高产品技术水平，完善产品品质，来满足用户的需求。

公司全体员工竭诚欢迎国内外用户光临指导，友好合作、互惠互利、共创辉煌。

Hangzhou world plastic Co., Ltd. is specializing in the production of plastic UPVC plastic pipe, pipe fittings, valves, ultra-filtration membrane, such as series of shell companies products. Products are widely used in chemical industry, water treatment, biotechnology, environmental protection, medicine, construction, paper, food, fire, electricity and other industries.

Company has strong technical strength, with a team of professional technical staff and research team, and with Zhejiang University and Zhejiang University of Technology and other research institutions have established close cooperative relations with advanced imported equipment and raw materials to produce quality, strictly in accordance with ISO9001 standards production management, quality control, development and production of a high-quality products vode.

Since its inception the company has consistently adhered to "unity, pragmatic, innovative, high-performance" of the enterprise development principle Competition in the world to raise the level of product technology, improve product quality to meet the needs of users.

The company all staff to welcome customers at home and abroad guidance, friendship and cooperation, mutual benefit, altogether creates magnificently.



管材/Pipe

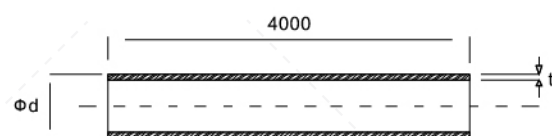
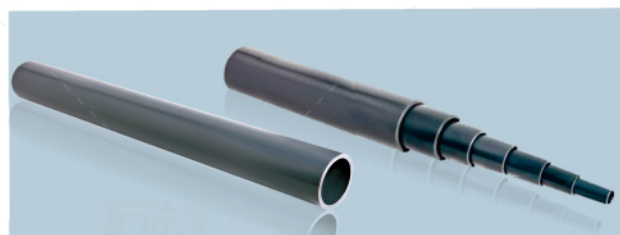

UPVC

公称尺寸 ϕd	壁厚 t mm			
	给水		工业	
	1.0Mpa	1.6Mpa	1.0Mpa	1.6Mpa
$\phi 20$		2.0		2.3
$\phi 25$		2.0		2.8
$\phi 32$		2.4		3.0
$\phi 40$	2.4	3.0	2.4	3.0
$\phi 50$	2.4	3.7	2.4	3.7
$\phi 63$	3.0	4.7	3.0	4.7
$\phi 75$	3.6	5.6	3.6	5.6
$\phi 90$	4.3	6.7	4.3	6.7
$\phi 110$	4.2	7.2	5.3	8.1
$\phi 140$	5.4	8.3	6.7	10.3
$\phi 160$	6.2	9.5	7.7	11.8
$\phi 200$	7.7	11.9	9.6	14.7
$\phi 225$	8.6	13.4	10.8	16.6
$\phi 250$	9.6	14.8	11.9	18.4
$\phi 280$	10.7	16.6	13.4	16.6
$\phi 315$	12.1	18.7	15.0	18.7
$\phi 355$	13.6	21.1	16.9	21.1
$\phi 400$	15.3	23.7	19.1	23.7

90° 弯头/Elbow90°

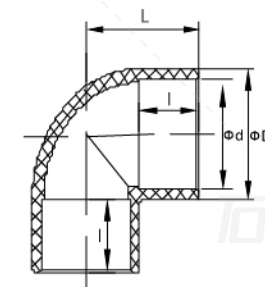

UPVC CPVC ABS

公称尺寸 ϕd	ϕD	I	L
$\phi 20$	27	16	28
$\phi 25$	32	19	33
$\phi 32$	40	22	40
$\phi 40$	49	26	49
$\phi 50$	60	31	58
$\phi 63$	73	38	70
$\phi 75$	87	44	82
$\phi 90$	104	51	101
$\phi 110$	126	61	120
$\phi 140$	161	76	155
$\phi 160$	184	86	171
$\phi 225$	252	119	235
$\phi 280$	312	146	298
$\phi 315$	352	163	335
$\phi 400$	440	206	428

三通/Tee

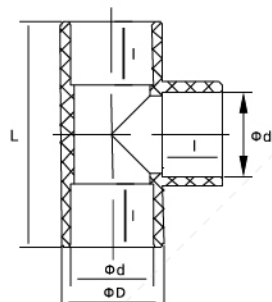

UPVC CPVC ABS

公称尺寸 ϕd	ϕD	I	L
$\phi 20$	27	16	54
$\phi 25$	32	19	64
$\phi 32$	40	22	78
$\phi 40$	49	26	94
$\phi 50$	60	31	114
$\phi 63$	73	38	140
$\phi 75$	87	44	164
$\phi 90$	104	51	194
$\phi 110$	126	61	235
$\phi 140$	161	76	293
$\phi 160$	184	86	332
$\phi 225$	252	119	468
$\phi 280$	312	146	590
$\phi 315$	352	165	670
$\phi 400$	440	206	826

45° 弯头/Elbow45°

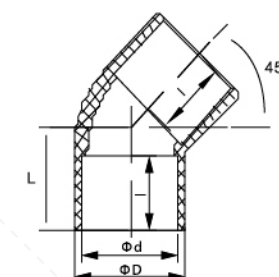

UPVC CPVC ABS

公称尺寸 ϕd	ϕD	I	L
$\phi 20$	27	16	22
$\phi 25$	32	19	28
$\phi 32$	40	22	32
$\phi 40$	49	26.5	36
$\phi 50$	60	31	45
$\phi 63$	73	38	52
$\phi 75$	87	44	62
$\phi 90$	104	51	72
$\phi 110$	126	61	86
$\phi 140$	161	76	108
$\phi 160$	184	86	116
$\phi 225$	252	119	172
$\phi 280$	312	146	260
$\phi 315$	345	165	290
$\phi 400$	440	206	385

直通/Coupling

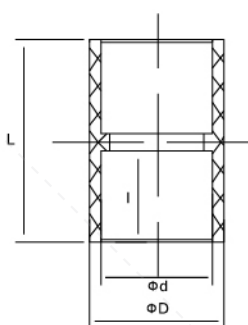

UPVC CPVC ABS

公称尺寸 ϕd	ϕD	I	L
$\phi 20$	27	16	35
$\phi 25$	32	19	40
$\phi 32$	40	22	47
$\phi 40$	49	26	56
$\phi 50$	60	31	65
$\phi 63$	76	38	79
$\phi 75$	89	44	91
$\phi 90$	104	51	107
$\phi 110$	126	61	127
$\phi 140$	161	76	160
$\phi 160$	184	86	180
$\phi 225$	252	119	243
$\phi 280$	312	146	302
$\phi 315$	352	163	338
$\phi 400$	440	206	420

管夹/Pipe carrier

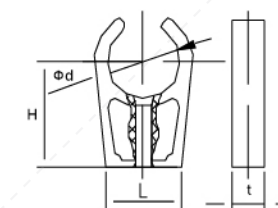
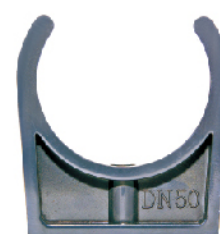

UPVC CPVC ABS

公称尺寸 ϕd	t	H	L
$\phi 20$	16	35	26
$\phi 25$	16	37	29
$\phi 32$	16	41	38
$\phi 40$	16	45	46
$\phi 50$	16	50	56
$\phi 63$	16	57	68
$\phi 75$	16	62	82
$\phi 90$	20	70	97
$\phi 110$	21	87	116

四通/Cross

UPVC CPVC ABS

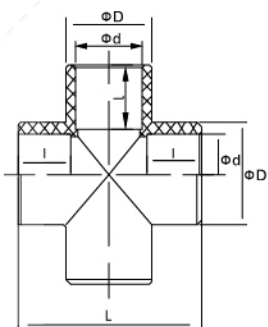

公称尺寸 Φd	ΦD	l	L
$\Phi 20$	27	16	54
$\Phi 25$	33	19	64
$\Phi 32$	40	22	78
$\Phi 40$	49	26	94
$\Phi 50$	60	31	114
$\Phi 63$	75	38	140
$\Phi 75$	87	44	164
$\Phi 90$	104	51	193
$\Phi 110$	125	61	231
$\Phi 140$	161	76	295
$\Phi 160$	182	86	333
$\Phi 225$	252	119	480
$\Phi 280$	312	144	585
$\Phi 315$	352	165	635
$\Phi 400$	440	206	825

异径四通/Reducer Cross

UPVC CPVC ABS

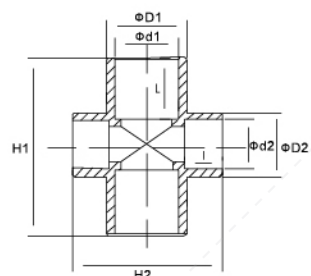

公称尺寸 $\Phi d1/d2$	$\Phi D1/D2$	L/l	H1/H2
$\Phi 75/25$	87/34	44/19	122/122
$\Phi 75/50$	87/60	44/31	142/140
$\Phi 90/50$	104/60	51/31	155/155
$\Phi 110/63$	126/73	61/38	190/190
$\Phi 140/50$	160/61	76/31	214/212
$\Phi 160/63$	181/75	76/38	225/244
$\Phi 160/110$	181/124	86/61	293/289
$\Phi 200/110$	222/124	106/61	330/328
$\Phi 225/110$	250/124	100/61	316/357
$\Phi 315/160$	352/184	163/86	570/515
$\Phi 315/225$	352/252	163/119	570/580

闷盖/Cap

UPVC CPVC ABS

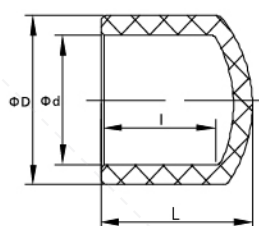

公称尺寸 Φd	ΦD	l	L
$\Phi 20$	26	16	24
$\Phi 25$	32	19	28
$\Phi 32$	38	22	32
$\Phi 40$	49	26	38
$\Phi 50$	58	31	46
$\Phi 63$	73	38	55
$\Phi 75$	87	44	65
$\Phi 90$	105	51	78
$\Phi 110$	127	61	83
$\Phi 140$	161	73	94
$\Phi 160$	184	76	98
$\Phi 225$	252	110	133
$\Phi 280$	308	141	167
$\Phi 315$	345	165	190
$\Phi 400$	432	206	230

一体法兰/Flange

UPVC CPVC ABS

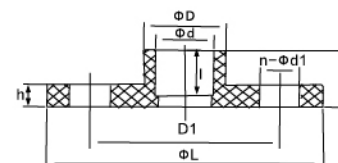

公称尺寸 Φd	ΦD	l	ΦL	D1	H	h	n- $\Phi d1$
$\Phi 20$	27	16	95	65	19	12	4- $\Phi 14$
$\Phi 25$	33	19	105	75	22	14	4- $\Phi 14$
$\Phi 32$	41	22	115	85	25	14	4- $\Phi 14$
$\Phi 40$	50	26	140	100	30	14	4- $\Phi 18$
$\Phi 50$	61	31	150	110	35	16	4- $\Phi 18$
$\Phi 63$	76	38	165	125	42	16	4- $\Phi 18$
$\Phi 75$	90	44	185	145	48	16	4- $\Phi 18$
$\Phi 90$	108	51	200	160	56	18	8- $\Phi 18$
$\Phi 110$	131	61	220	180	66	19	8- $\Phi 18$

活套法兰/Flange

UPVC CPVC ABS

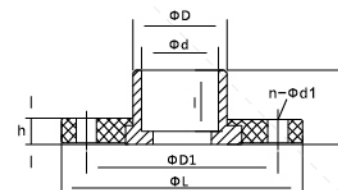

公称尺寸 Φd	ΦD	l	ΦL	D1	H	h	n- $\Phi d1$
$\Phi 20$	27	16	95	65	19	16	4- $\Phi 14$
$\Phi 25$	33	19	105	75	22	16	4- $\Phi 14$
$\Phi 32$	41	22	115	85	25	19	4- $\Phi 14$
$\Phi 40$	50	26	140	100	30	19	4- $\Phi 18$
$\Phi 50$	61	31	150	110	35	20	4- $\Phi 18$
$\Phi 63$	76	38	165	125	42	22	4- $\Phi 18$
$\Phi 75$	90	44	185	145	48	24	4- $\Phi 18$
$\Phi 90$	108	51	200	160	56	30	8- $\Phi 18$
$\Phi 110$	131	61	220	180	66	30	8- $\Phi 18$
$\Phi 140$	161	76	250	210	101	32	8- $\Phi 18$
$\Phi 160$	184	86	285	240	113	33	8- $\Phi 22$
$\Phi 225$	254	119	340	295	126	43	8/12- $\Phi 22$
$\Phi 280$	310	146	415	350	156	52	12- $\Phi 22$
$\Phi 315$	345	165	445	400	189	60	12- $\Phi 22$
$\Phi 400$	432	206	565	515	231	65	16- $\Phi 26$

盲法兰/Flange Cap

EPDM

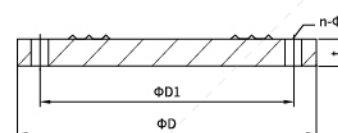

公称尺寸 Φd	ΦD	D1	t	n- $\Phi d1$
$\Phi 20$	95	65	16	4- $\Phi 14$
$\Phi 25$	105	75	16	4- $\Phi 14$
$\Phi 32$	115	85	19	4- $\Phi 14$
$\Phi 40$	140	100	19	4- $\Phi 18$
$\Phi 50$	150	110	20	4- $\Phi 18$
$\Phi 63$	165	125	22	4- $\Phi 18$
$\Phi 75$	185	145	24	4- $\Phi 18$
$\Phi 90$	200	160	30	8- $\Phi 18$
$\Phi 110$	220	180	30	8- $\Phi 18$
$\Phi 140$	250	210	32	8- $\Phi 18$
$\Phi 160$	285	240	33	8- $\Phi 22$
$\Phi 225$	340	295	35	8- $\Phi 22$
$\Phi 280$	396	350	35	12- $\Phi 22$
$\Phi 315$	445	400	35	12- $\Phi 22$
$\Phi 400$	565	515	35	16- $\Phi 26$

平缩接/Reducer

UPVC CPVC ABS

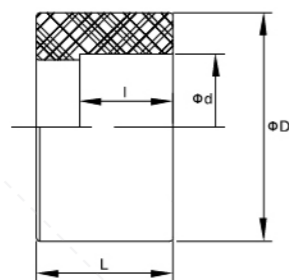
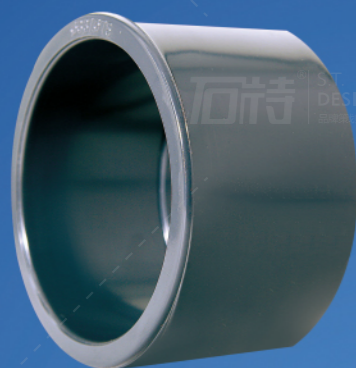

公称尺寸 Φ	ΦD	Φd	l	L
Φ25/20	25	20	16	19
Φ32/20	32	20	16	22
Φ32/25	32	25	19	22
Φ40/25	40	25	19	26
Φ40/32	40	32	22	26
Φ50/32	50	32	22	31
Φ50/40	50	40	26	31
Φ63/32	63	32	22	38
Φ63/40	63	40	26	38
Φ63/50	63	50	31	38
Φ75/50	75	50	31	44
Φ75/63	75	63	38	44
Φ90/63	90	63	38	51
Φ90/75	90	75	44	51
Φ110/63	110	63	38	61
Φ110/75	110	75	44	61
Φ110/90	110	90	51	61
Φ140/110	140	110	61	76
Φ160/110	160	110	61	86
Φ160/140	160	140	76	86
Φ225/110	225	110	61	119
Φ225/160	225	160	86	119
Φ280/225	280	225	119	146
Φ315/225	315	225	119	163
Φ315/280	315	280	146	165
Φ400/315	400	315	165	206

异径三通/Reducer Tee

UPVC CPVC ABS

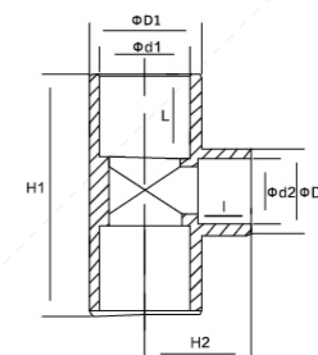

公称尺寸 Φd1/d2	ΦD1/D2	L/l	H1/H2
Φ25/20	32/27	19/16	65/32
Φ32/20	40/27	22/16	70/34
Φ32/25	40/32	22/19	76/39
Φ40/20	49/27	26/16	79/40
Φ40/25	49/32	26/19	82/42
Φ40/32	49/40	26/22	92/46
Φ50/20	60/27	31/16	89/46
Φ50/25	60/32	31/19	94/49
Φ50/32	60/40	31/22	99/50
Φ50/40	60/49	31/26	111/56
Φ63/25	75/32	38/19	108/56
Φ63/32	73/40	38/22	115/58
Φ63/40	73/49	38/26	120/60
Φ63/50	75/60	38/31	135/68
Φ75/32	87/40	44/22	126/65
Φ75/50	87/60	44/31	142/70
Φ90/32	104/40	51/22	140/73
Φ90/50	104/60	51/31	155/78
Φ90/63	104/73	51/38	170/85
Φ110/32	126/40	61/22	160/85
Φ110/63	126/73	61/38	190/95
Φ110/75	126/87	61/44	212/102
Φ140/50	160/61	76/31	214/106
Φ140/63	160/73	76/38	237/118
Φ140/75	160/87	76/44	237/120
Φ140/110	160/126	76/61	272/140
Φ160/63	181/75	76/38	225/122
Φ160/110	181/124	86/61	293/145
Φ200/110	222/124	106/61	330/164
Φ225/110	250/124	100/61	310/179
Φ225/160	252/184	119/86	416/205
Φ280/160	312/184	146/86	541/230
Φ280/225	312/252	146/119	541/264
Φ315/160	352/184	163/86	570/250
Φ315/225	352/252	163/119	570/285
Φ400/315	440/352	206/163	748/380

大小头/Reducer Coupling

UPVC CPVC ABS

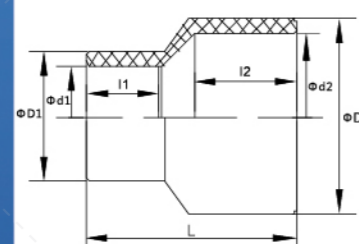
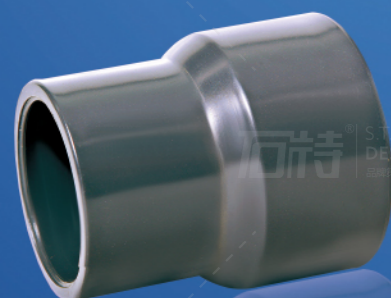

公称尺寸 Φ	ΦD1	ΦD2	Φd1	Φd2	l1	l2	L
Φ25/20	27	33	20	25	16	19	43
Φ32/20	27	41	20	32	16	22	46
Φ32/25	33	41	25	32	19	22	51
Φ40/25	33	50	25	40	19	26	55
Φ40/32	40	50	32	40	22	26	57
Φ50/32	40	61	32	50	22	31	66
Φ50/40	50	61	40	50	26	31	70
Φ63/40	50	75	40	63	26	38	80
Φ63/50	60	75	50	63	31	38	85
Φ75/50	60	88	50	75	31	44	93
Φ75/63	75	90	63	75	38	44	96
Φ90/63	73	104	63	90	38	51	112
Φ90/75	88	106	75	90	44	51	115
Φ110/75	88	125	75	110	44	61	132
Φ110/90	106	125	90	110	51	61	142
Φ140/110	125	162	110	140	61	76	163
Φ160/110	126	185	110	160	61	86	176
Φ160/140	160	183	140	160	76	86	186
Φ225/110	126	252	110	225	61	119	250
Φ225/160	182	252	160	225	86	109	236
Φ280/225	250	312	225	280	119	146	310
Φ315/225	250	352	225	315	119	163	334
Φ315/280	312	355	280	315	146	163	345
Φ400/315	355	432	315	400	165	206	420

45°三通/Tee 45°

UPVC CPVC ABS

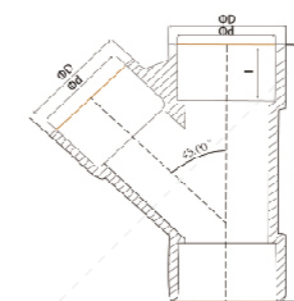

公称尺寸 Φd	ΦD	l	L
Φ50	60	31	141
Φ63	75	38	176
Φ75	88	44	204
Φ90	106	51	247
Φ110	129	57	290
Φ160	185	76	413

外丝接头/Male Adaptor

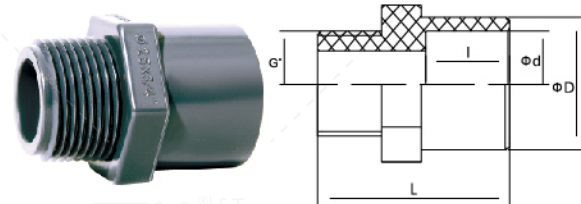

■ UPVC ■ CPVC ■ ABS

公称尺寸Φd	ΦD	I	L	G"
Φ20	26.5	16	44.5	1/2"
Φ25	32	18.5	47	3/4"
Φ32	39.5	22	55	1"
Φ40	49	26	62	1-1/4"
Φ50	60	31	64	1-1/2"
Φ63	73	38	72.5	2"
Φ75	87	44	84	2-1/2"
Φ90	105	51	97	3"
Φ110	124	61	118.5	4"

活接由令 I /Union

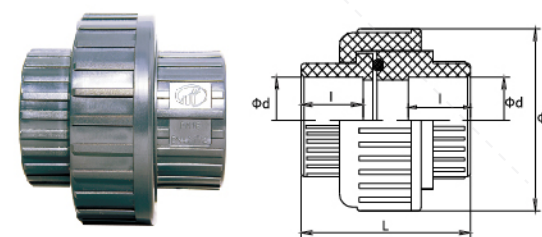

■ UPVC ■ CPVC ■ ABS

公称尺寸Φd	ΦD	I	L
Φ20	45	16	57
Φ25	55	19	63
Φ32	66	22	71
Φ40	82	26	87
Φ50	98	31	89
Φ63	120	38	98
Φ75	140	44	114
Φ90	148	51	124
Φ110	175	61	142

内丝接头/Female Adapter

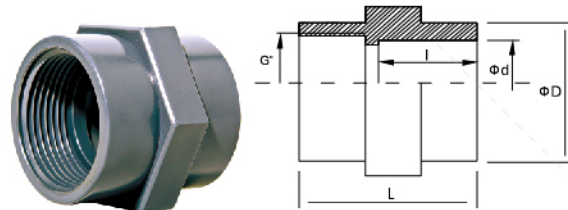

■ UPVC ■ CPVC ■ ABS

公称尺寸Φd	ΦD	I	L	G"
Φ20	27	19.5	39.5	1/2"
Φ25	33	21.5	41	3/4"
Φ32	40	23.5	47	1"
Φ40	49	26	51	1-1/4"
Φ50	63	31	56	1-1/2"
Φ63	73	38	64	2"
Φ75	89	44	83	2-1/2"
Φ90	105	51	93	3"
Φ110	125	60	107	4"

活接由令 II /Union

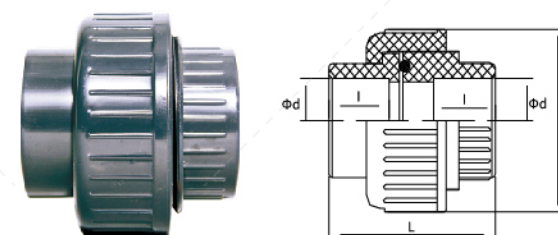

■ UPVC ■ CPVC ■ ABS

公称尺寸Φd	ΦD	I	L
Φ20	47	16	46
Φ25	53	19	51
Φ32	62	24	58
Φ40	75	26	68
Φ50	85	31	80
Φ63	104	38	98
Φ75	127	44	110
Φ90	148	51	124
Φ110	175	61	142

内丝弯头/Female Elbow 90°

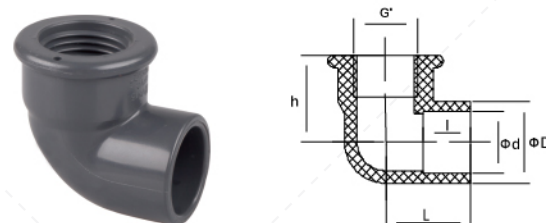

■ UPVC ■ CPVC ■ ABS

公称尺寸Φd	ΦD	I	h	L	G"
Φ20-1/4"	27	16	27	26	1/4"
Φ20-1/2"	27	16	28	27	1/2"
Φ25-3/4"	33	19	35	36	3/4"
Φ32-1"	38	22	42	39	1"

外丝活接/Union

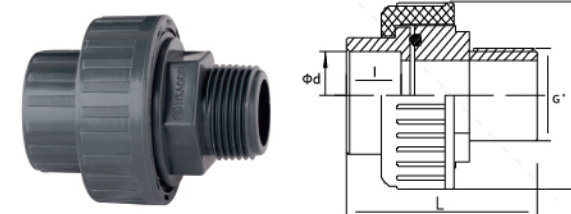

■ UPVC ■ CPVC ■ ABS

公称尺寸Φd	ΦD	I	L	G"
Φ20	47	16	65	1/2"
Φ25	55	19	76	3/4"
Φ32	66	22	80	1"

内丝三通/Female Tee

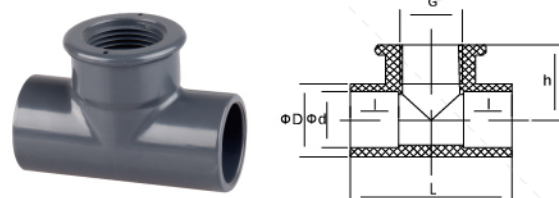

■ UPVC ■ CPVC ■ ABS

公称尺寸Φd	ΦD	I	h	L	G"
Φ20-1/4"	27	16	27	51	1/4"
Φ20-1/2"	27	16	28	54	1/2"
Φ25-3/4"	33	19	35	70	3/4"
Φ32-1"	38	22	42	80	1"

内丝活接由令/Female Union

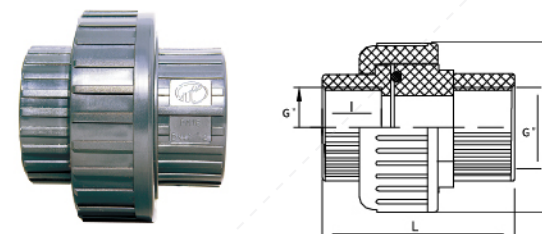

■ UPVC ■ CPVC ■ ABS

公称尺寸Φd	ΦD	I	L	G"
Φ20	45	22	57	1/2"
Φ25	55	25	63	3/4"
Φ32	66	28	71	1"
Φ40	82	26	87	1-1/4"
Φ50	98	31	89	1-1/2"
Φ63	120	38	98	2"

法兰垫片/Flange Gaske

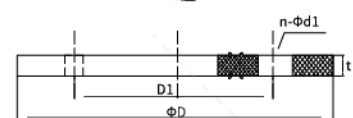

EPDM

公称尺寸 Φd	ΦD	D1	t	n-Φd1
Φ20	95	65	3	4-Φ14
Φ25	105	75	3	4-Φ14
Φ32	115	85	3	4-Φ14
Φ40	140	100	3	4-Φ18
Φ50	150	110	3	4-Φ18
Φ63	165	125	3	4-Φ18
Φ75	185	145	3.5	4-Φ18
Φ90	200	160	3.5	4-Φ18
Φ110	220	180	3.5	4-Φ18
Φ140	250	210	4	8-Φ18
Φ160	285	240	4	8-Φ22
Φ225	340	295	4.5	8-Φ22
Φ280	396	350	4.5	12-Φ22
Φ315	445	400	4.5	12-Φ22
Φ400	565	515	5	16-Φ26

压力表接头/Female Adapter

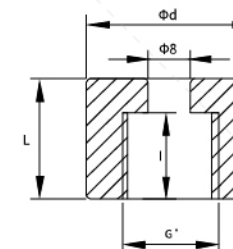

UPVC CPVC ABS

公称尺寸 Φd	Φd	l	L	G"
Φ20-1/4"	20	16	16	1/4"
Φ20-3/8"	20	16	16	3/8"
Φ20-M12.5	20	16	16	M12.5*1.5
Φ20-M14	20	13	19	M14*1.5
Φ25-M14	25	13	19	M14*1.5
Φ25-1/2"	25	20	20	1/2"
Φ32-M20	32	14	22	M20*1.5
Φ40-1"	40	26	26	1"
Φ50-3/8"	50	16	31	3/8"

流量计/Flow Meter

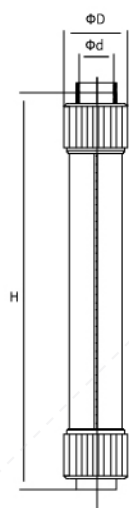

UPVC PC

规格型号	测量范围	Φd	ΦD	H
LZS-20	16-160L/h	20	45	280
LZS-20	25-250L/h	20	45	280
LZS-20	60-600L/h	20	45	280
LZS-32	100-1000L/h	32	68/60	380/226
LZS-32	160-1600L/h	32	68/60	380/226
LZS-32	250-2500L/h	32	68/60	380/226
LZS-40	0.4-4m ³ /h	40	74	288
LZS-40	0.6-6m ³ /h	40	74	288
LZS-63	1-10m ³ /h	63	98	435/341
LZS-63	1.6-16m ³ /h	63	98	435/341
LZS-75	5-25m ³ /h	75	122	430
LZS-75	8-40m ³ /h	75	122	430
LZS-75	12-60m ³ /h	75	122	430
LZS-110	18-120m ³ /h	110	220	555
LZS-140	25-150m ³ /h	140	250	555
LZS-140	25-180m ³ /h	140	250	555
LZS-160	25-250m ³ /h	160	285	555

马鞍四通/Hoop Cross

UPVC CPVC ABS



型号

Φ140/50/63
Φ160/50/63
Φ225/63/75
Φ250/63/75

马鞍三通/Hoop Tee

UPVC CPVC ABS



型号

Φ140/50/63
Φ160/50/63
Φ225/63/75
Φ250/63/75

取样阀/Labcock Ball Valve

UPVC CPVC

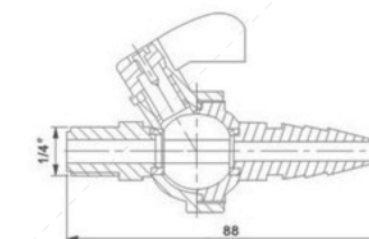

Y型过滤器/Y-Sediment Strainers

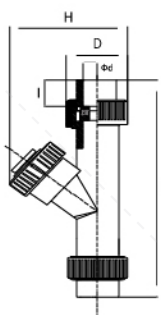

UPVC

公称尺寸 Φd	D	l	L	H
Φ20	45	16	165	90
Φ25	53	19	167	103
Φ32	62	22	192	130
Φ40	75	26	211	151
Φ50	85	31	261	167
Φ63	104	38	264	182
Φ75	127	44	261	206
Φ90	148	51	261	210
Φ110	175	61	290	235

透明双由令球阀 Double Union Ball Valve

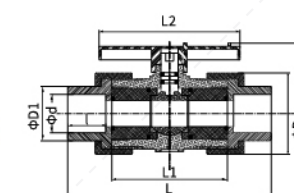

公称尺寸Φd	ΦD1	ΦD	l	L1	L2	L	H
Φ20	31	45	16	60	78	115	48
Φ25	37	55	19	73	92	132	57
Φ32	44	66	22	78	100	147	66
Φ40	54	82	26	87	110	169	76
Φ50	65	98	35	92	121	184	88
Φ63	79	120	38	112	147	205	108

双由令球阀
Double Union Ball Valve

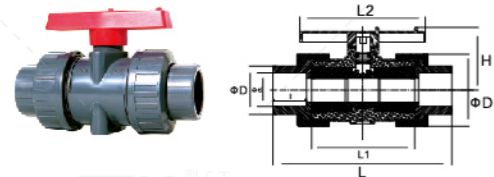

UPVC CPVC ABS

公称尺寸 Φd	ΦD1	ΦD	I	L1	L2	L	H
Φ20	31	45	16	60	78	115	48
Φ25	37	55	19	73	92	132	57
Φ32	44	66	22	78	100	147	66
Φ40	54	82	26	87	110	169	76
Φ50	65	98	35	92	121	174	88
Φ63	79	120	38	112	147	205	108
Φ75	91	140	44	137	180	245	116
Φ90	108	167	51	180	190	294	128
Φ110	132	224	61	202	239	341	162

隔膜阀/Diaphragm Valve

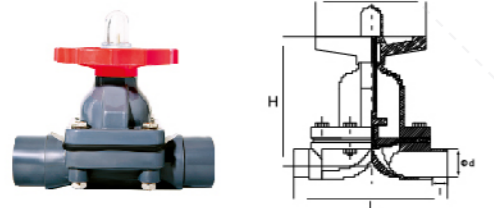

UPVC CPVC ABS

公称尺寸 Φd	A	I	H	L
Φ20	55	16	60	97
Φ25	68	19	100	112
Φ32	100	22	120	125
Φ40	100	26	122	157
Φ50	120	31	150	190
Φ63	140	35	168	225
Φ75	205	44	245	285
Φ90	225	51	285	350
Φ110	290	61	350	385
Φ140	318	76	410	380
Φ160	400	86	430	550

双由令隔膜阀
Double Union Diaphragm Valve

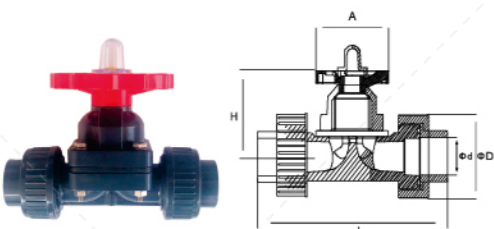

UPVC CPVC ABS

公称尺寸 Φd	A	D	H	L
Φ20	55	45	60	130
Φ25	68	53	100	150
Φ32	100	62	120	168
Φ40	100	75	122	210
Φ50	120	85	150	245
Φ63	140	104	168	295

单由令止回阀/Clack Valve

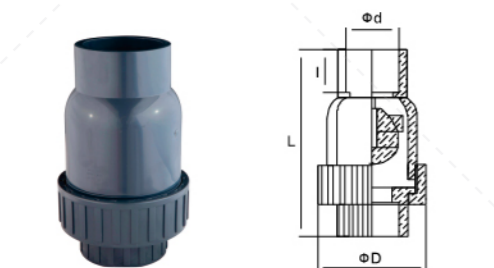

UPVC CPVC ABS

公称尺寸 Φd	ΦD	I	L
Φ20	49	16	94
Φ25	59	19	109
Φ32	65	22	118
Φ40	82	26	142
Φ50	98	31	152
Φ63	105	38	176
Φ75	126	44	208
Φ90	168	51	246
Φ110	193	61	310

止回阀/Clack Valve

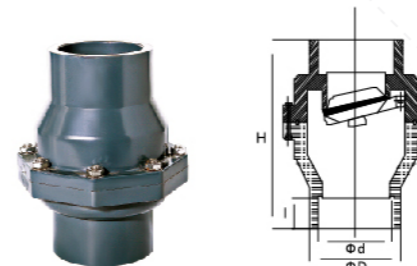

UPVC CPVC ABS

公称尺寸 Φd	ΦD	I	L
Φ20	28	16	60
Φ25	35	19	65
Φ32	43	22	80
Φ40	53	26	106
Φ50	63	31	126
Φ63	77	38	158
Φ75	91	44	164
Φ90	108	51	190
Φ110	130	61	230
Φ140	164	76	300
Φ160	186	86	320
Φ225	255	112	400
Φ280	313	146	480

蝶阀/Butterfly Valve

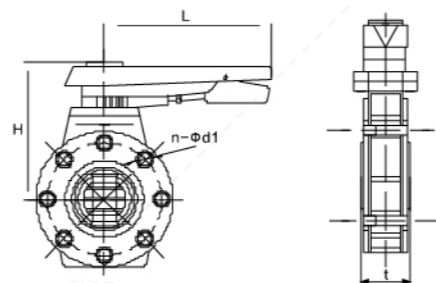

UPVC CPVC ABS

公称尺寸 Φd	L	H	t	n-Φd1
Φ63	200	160	43	4-Φ18
Φ75	200	170	46	4-Φ18
Φ90	240	195	49	8-Φ18
Φ110	240	210	58	8-Φ18
Φ140	304	245	64	8-Φ18
Φ160	304	260	70	8-Φ18
Φ225	304	310	88	8-Φ22
Φ280	245	355	98	12-Φ22
Φ315	245	400	108	12-Φ22
Φ400	210	445	98	16-Φ26

底阀/Bottom Valve

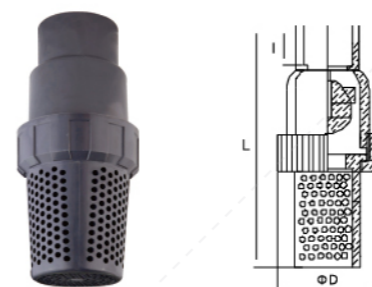

UPVC CPVC ABS

公称尺寸 Φd	ΦD	I	L
Φ20	49	16	130
Φ25	59	19	146
Φ32	65	22	180
Φ40	82	26	192
Φ50	98	31	250
Φ63	105	38	270
Φ75	126	44	300
Φ90	168	51	360
Φ110	193	61	440
Φ140	250	76	460
Φ160	285	86	480
Φ225	340	119	500

电动球阀/Electric Ball Valve

UPVC CPVC ABS

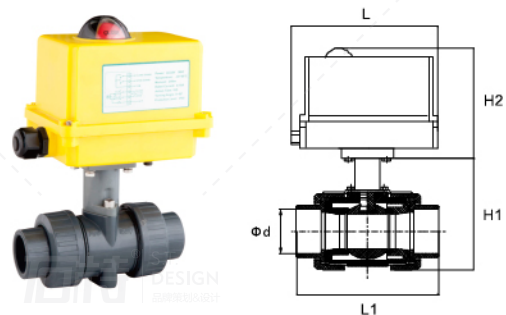

公称尺寸Φd	H1	H2	L	L1
Φ20	70	130	165	112
Φ25	88	130	165	132
Φ32	100	130	165	144
Φ40	120	130	165	165
Φ50	140	130	165	171
Φ63	170	130	165	200
Φ75	190	130	165	270
Φ90	210	130	165	300
Φ110	270	130	165	328

气动球阀/Pneumatic Ball Valve

UPVC CPVC ABS

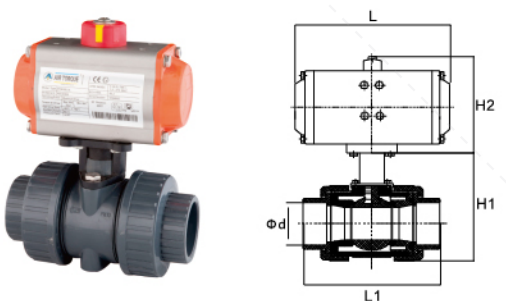

公称尺寸Φd	H1	H2	L	L1
Φ20	70	130	160	112
Φ25	88	130	160	132
Φ32	100	130	160	144
Φ40	120	130	160	165
Φ50	140	130	160	171
Φ63	170	130	160	200
Φ75	190	130	160	270
Φ90	210	130	160	300
Φ110	270	130	160	328

电动蝶阀/Electric Butterfly Valve

UPVC CPVC ABS

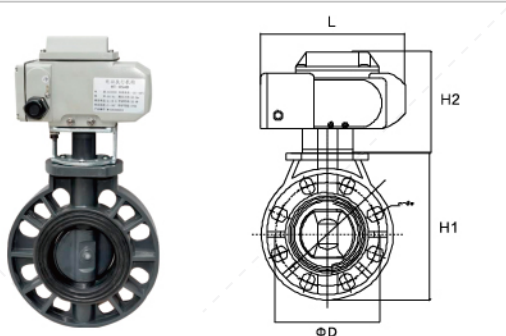

公称尺寸Φd	H1	H2	L	ΦD
Φ63	200	150	160	125
Φ75	220	150	160	145
Φ90	240	150	160	160
Φ110	270	150	160	180
Φ140	300	150	160	210
Φ160	320	180	160	240
Φ225	380	180	160	295
Φ280	450	180	160	350
Φ315	550	180	160	400

气动蝶阀
Pneumatic Butterfly Valve

UPVC CPVC ABS

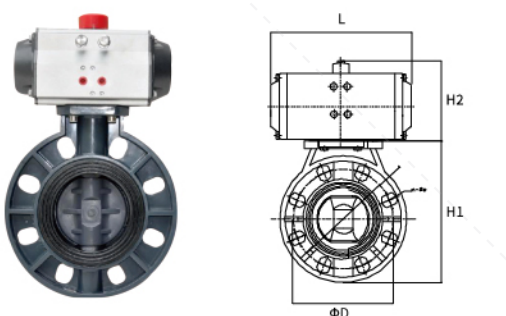

公称尺寸Φd	H1	H2	L	ΦD	n-Φe
Φ63	200	130	210	125	4-Φ18
Φ75	220	130	210	145	4-Φ18
Φ90	240	130	210	160	8-Φ18
Φ110	270	150	210	180	8-Φ18
Φ140	300	150	210	210	8-Φ18
Φ160	320	150	210	240	8-Φ18
Φ225	380	170	300	295	8-Φ22
Φ280	450	170	300	350	12-Φ22
Φ315	550	170	300	400	12-Φ22

排气阀/Exhaust Valve

UPVC PA6

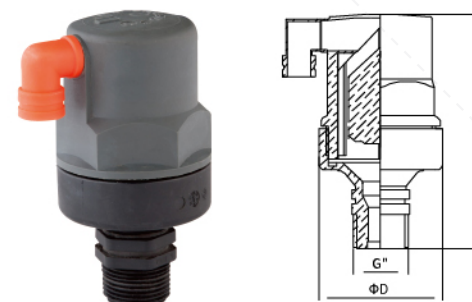

公称尺寸Φd	D	H	G
Φ20	75	140	1/2"
Φ32	75	140	1"
Φ50	100	270	1-1/2"
Φ63	100	270	2"

安全阀/背压阀
Safety valve/Back pressure valve

隔膜压力表
Diaphragm pressure gauge



膜片式脉冲阻尼器
Diaphragm pulse damper

空气室式脉冲阻尼器
Air pulse damper



透明管材/Pipe

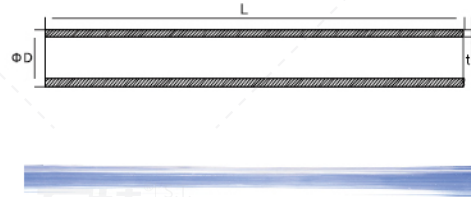

Clear UPVC

公称尺寸ΦD	t mm	D	L
Φ20	2.3	20	3000
Φ25	2.8	25	3000
Φ32	3.2	32	3000
Φ40	3.2	40	3000
Φ50	3.5	50	3000
Φ63	4.0	63	3000
Φ75	4.5	75	3000
Φ90	4.5	90	3000
Φ110	5.0	110	3000
Φ140	5.5	140	3000
Φ160	6.0	160	3000
Φ225	6.5	225	3000

透明三通/Tee

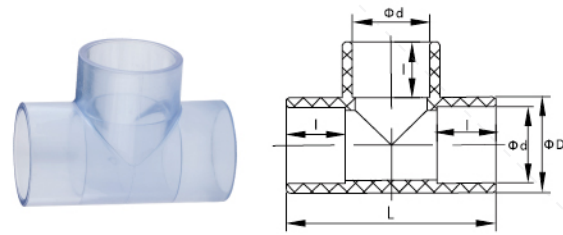

Clear UPVC

公称尺寸Φd	ΦD	I	L
Φ20	27	16	54
Φ25	32	19	64
Φ32	40	22	78
Φ40	49	26	94
Φ50	60	31	114
Φ63	73	38	140
Φ75	87	44	164
Φ90	104	51	194
Φ110	126	61	235
Φ140	161	76	293
Φ160	184	86	332

透明直通/Coupling

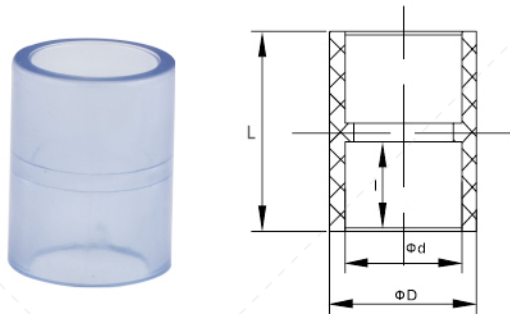

Clear UPVC

公称尺寸Φd	ΦD	I	L
Φ20	27	16	35
Φ25	32	19	40
Φ32	40	22	47
Φ40	49	26	56
Φ50	60	31	65
Φ63	76	38	79
Φ75	89	44	91
Φ90	104	51	107
Φ110	126	61	127
Φ140	161	76	160
Φ160	184	86	180

透明弯头/Elbow90°

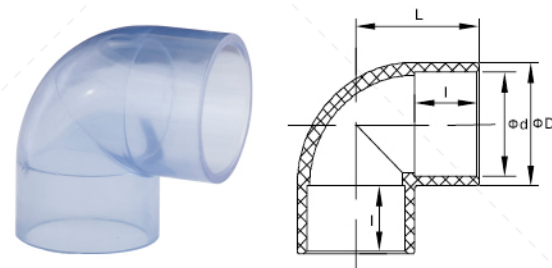

Clear UPVC

公称尺寸Φd	ΦD	I	L
Φ20	27	16	28
Φ25	32	19	33
Φ32	40	22	40
Φ40	49	26	49
Φ50	60	31	58
Φ63	73	38	70
Φ75	87	44	82
Φ90	104	51	101
Φ110	126	61	120
Φ140	161	76	155
Φ160	184	86	161

透明弯头/Elbow45°

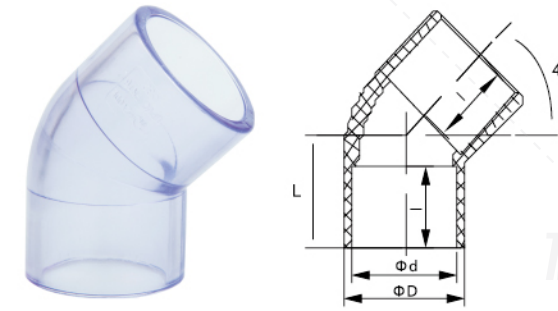

Clear UPVC

公称尺寸Φd	ΦD	I	L
Φ20	27	16	22
Φ25	32	19	28
Φ32	40	22	32
Φ40	49	26	36
Φ50	60	31	45
Φ63	73	38	52
Φ75	87	44	62
Φ90	104	51	72
Φ110	126	61	86
Φ140	161	76	108
Φ160	184	86	116

透明活接由令/Union

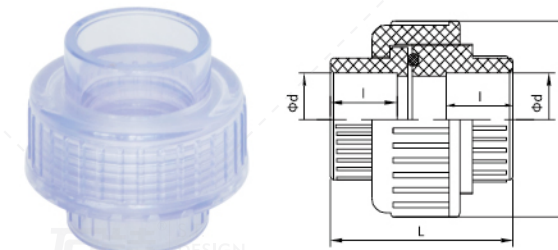

Clear UPVC

公称尺寸Φd	ΦD	I	L
Φ20	45	16	46
Φ25	53	19	51
Φ32	62	22	58
Φ40	75	26	68
Φ50	85	31	80
Φ63	104	38	98

透明外丝接头/Male Adaptor

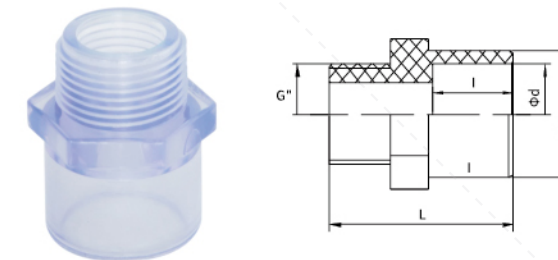

Clear UPVC

公称尺寸Φd	ΦD	I	L	G"
Φ20	27	16	44.5	1/2"
Φ25	33	19	47	3/4"
Φ32	38	22	55	1"
Φ40	49	26	62	1-1/4"
Φ50	60	31	64	1-1/2"
Φ63	73	38	72.5	2"

透明闷盖/Cap

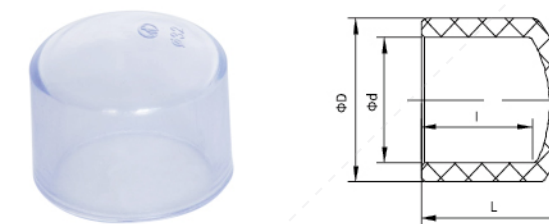

Clear UPVC

公称尺寸Φd	ΦD	I	L
Φ20	26	16	24
Φ25	32	19	28
Φ32	38	22	32
Φ40	49	26	38
Φ50	58	31	46
Φ63	73	38	55
Φ75	87	44	65
Φ90	105	51	78
Φ110	127	61	83

马鞍(弧面)接头 Cambered Surface Adaptor

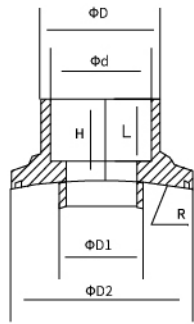

UPVC CPVC ABS

公称尺寸 Φ	ΦD	Φd	ΦD1	ΦD2	R	H	L
Φ75/32	40	32	35	70	37.5	36	25
Φ90/32	40	32	28	60	45	26	22
Φ90/50	60	50	55	85	45	37	31
Φ110/32	40	32	29	60	55	26	22
Φ110/50	60	50	55	100	55	37	31
Φ110/63	72	63	60	100	55	42	37
Φ140/32	40	32	29	70	70	27	22
Φ140/50	60	50	55	100	70	42	41
Φ140/63	72	63	55	100	70	42	37
Φ160/32	40	32	29	70	80	27	22
Φ160/50	60	50	55	100	80	37	31
Φ160/63	72	63	55	100	80	42	37
Φ225/32	40	32	29	70	112.5	27	22
Φ225/50	60	50	55	100	112.5	37	31
Φ225/63	72	63	60	100	112.5	42	37
Φ225/75	88	75	70	118	112.5	42	46
Φ225/90	104	90	90	160	112.5	60	51
Φ250/32	40	32	29	70	125	26	22
Φ250/63	72	63	60	100	125	41	37
Φ250/75	86	75	70	115	125	42	38
Φ280/32	40	32	29	70	140	28	22
Φ280/50	60	50	55	100	140	37	31
Φ280/63	73	63	60	100	140	42	37
Φ280/75	88	75	70	115	140	46	38
Φ315/32	40	32	29	70	157.5	28	22
Φ315/50	60	50	55	100	157.5	37	31
Φ315/63	74	63	60	100	157.5	42	37
Φ315/75	88	75	70	118	157.5	46	38
Φ315/90	104	90	90	160	157.5	60	51

卡套(拷贝林)/Coupling

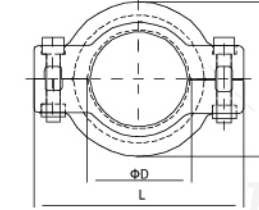

UPVC PA6

公称尺寸 Φ	ΦD	L	H	T
Dn25	33	92	65	36
Dn32	42	105	76	45
Dn40	48	110	83	45
Dn50	60	130	92	45
DN65A	73	137	107	45
DN65B	76	137	107	45
DN80	89	165	134	46
Dn100	114	190	160	52
DN150	168	270	230	54

透明卡套(拷贝林)接头 Clear Coupling Adaptor

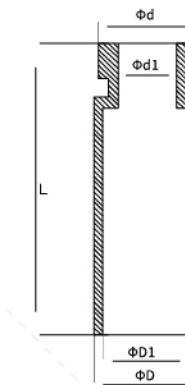

Clear UPVC

公称尺寸Φ	Φd	Φd1	ΦD	ΦD1	L
Dn50	60	50	63	55	180
DN65-A	73	60	75	63	180
DN65-B	76	60	75	63	180

卡套(拷贝林)接头/Coupling Adaptor

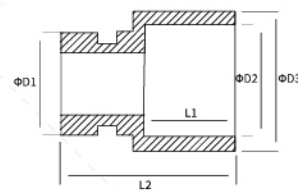

UPVC CPVC ABS

公称尺寸 Φ	ΦD1	ΦD2	ΦD3	L1	L2
DN25-A	32	32	40	23	56
DN25-B	33.4	32	40	23	56
DN32-32	42	32	40	22	64
DN32-40	42	40	50	26	59
DN40-40	48	40	50	28	59
DN40-50	48	50	60	31	66
DN50-50	60	50	63	31	64
DN50-60	60	60	74	38	76
DN50-63	60	63	74	38	76
DN65-A	73	75	87	43	79
DN65-B	76	75	87	43	79
Dn80	89	90	104	51	85
DN100A	114	110	125	61	96
DN100B	114	94	110	61	95

软管接头/Hose Adaptor

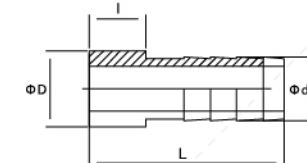

UPVC CPVC ABS

公称尺寸Φ	ΦD	Φd	l	L
20/16	20	16	16	50
20/19	20	19	16	54
25/25	25	25	19	79
32/30	32	30	22	90
40/40	40	40	26	95
50/50	50	50	31	105
63/60	63	60	38	120

超滤膜壳

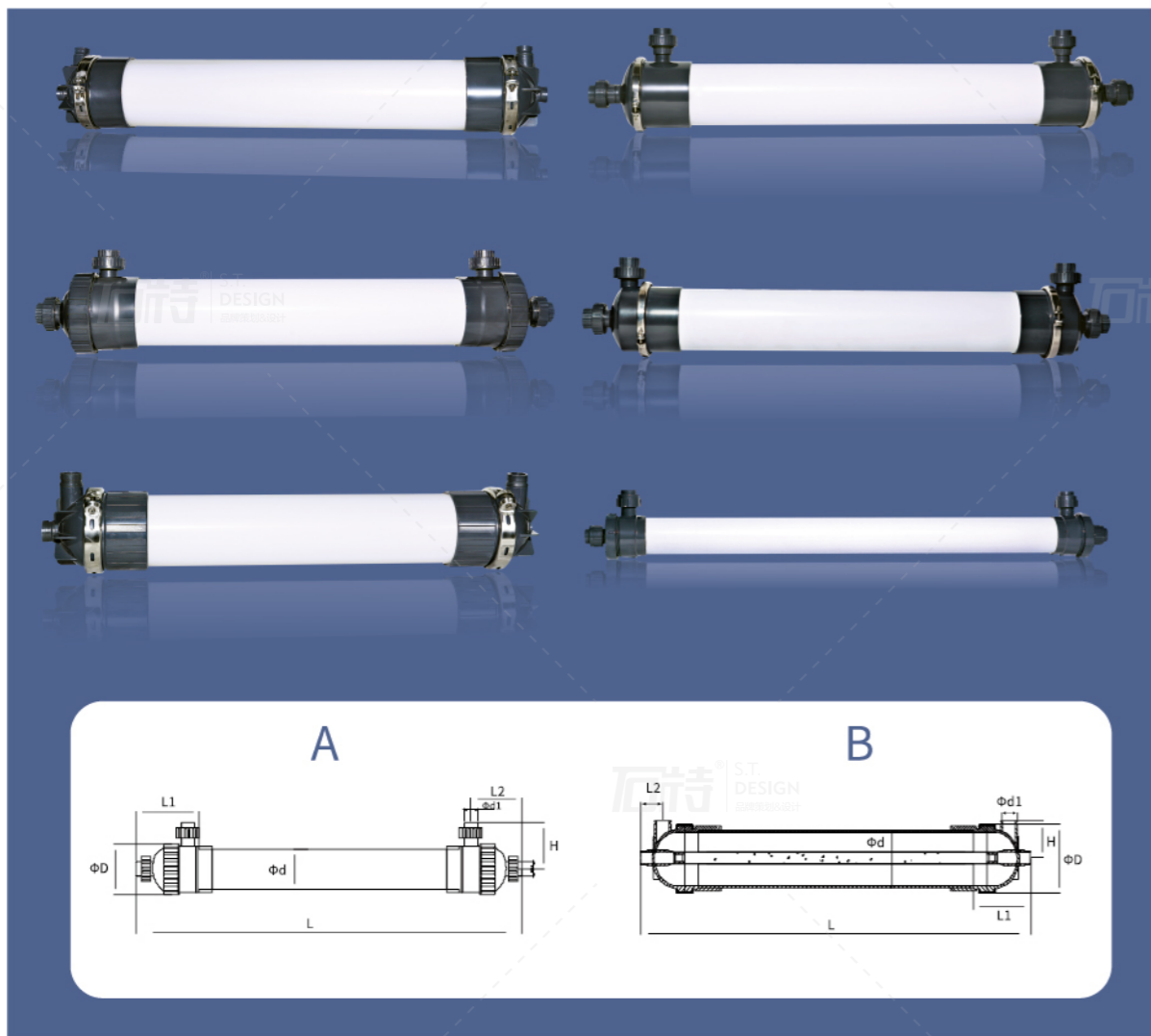

型号规格	Φd	ΦD	L1	L2	H	$\Phi d1$	备注
2"-A	50	85	90	72	56	12	软管接头
4"-A	90	110	115	101	110	32	由令进出水口
5"-A	140	160	165	140	170	32/40	由令进出水口
6"-A	160	195	207	183	164	40	由令进出水口
6"-B	160	195	176	112	158	40	由令进出水口
6"-C	160	220	274	214	170	40/50	由令进出水口
8"-A-1	200	240	243	208	187	50	由令进出水口
8"-A-2	200	230	243	208	187	50	由令进出水口
8"-A-3	200	245	210	170	150	60	拷贝林进出水口
8"-B	200	235	175	73	158	50	拷贝林、由令进出水口
9"-B-1	225	290	173	73	172	50	拷贝林、由令进出水口
9"-B-2	225	251	177	67	160.5	60	拷贝林进出水口
10"-B	250	290	173	73	172	50	拷贝林、由令进出水口
12"-A	315	350	208	263	224	75	拷贝林进出水口

注：可以按客户要求尺寸定制

耐高温膜壳



型号
4"
6"
8"
10"

注：使用温度 $\leq 95^{\circ}\text{C}$

MBR柱式膜壳

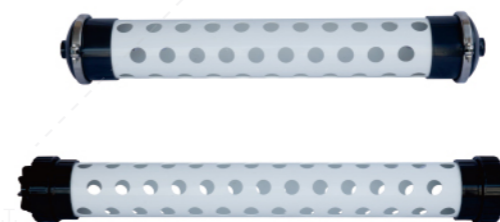

型号
6"
7"

膜绑带垫块



型号
5"
6"
8"
9"
10"
12"

水箱接头/Tank Adaptor



堵漏针



MBR帘式膜槽



型号
20CM
38CM
48CM
78CM
80CM
125CM

中心管

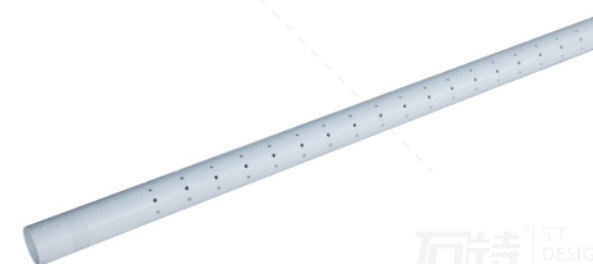

型号
定制

胶水/Cement



卷式膜壳



型号
40 40
80 40

透明膜壳



型号
2"
4"

ABS超滤膜壳



型号
4"
6"





UPVC产品物理机械性能

标准引用: GB/T 10002.1-2006 GB/T10002.2-2003 GB/T 4219-2008

性能	指标	
	管材	管件
密度Kg/m ³	1330-1460	1330-1460
维卡软化温度°C	≥80	≥72
纵向回缩率%	≤5	
落锤冲击试验TIR%	≤10	
液压试验	无破裂	无破裂
二氯甲烷浸泡试验	表面无变化	
坠落试验		无破裂
烘箱试验		无起泡、开裂现象
卫生性能	符合饮用水卫生GB/T17219-98标准	



产品特性

- 重量轻---比重为铸铁管的1/6, 安装运输方便, 节约时间和费用。
- 耐腐蚀---具有良好的耐酸、耐碱、耐电化学腐蚀, 使用中不会出现点腐蚀现象, 具体详见耐腐蚀表。
- 阻力小---内壁光滑, 流体阻力小, 不结垢, 水头损失比铸铁管低30%以上。
- 耐老化---化学稳定性好, 正常使用寿命可达50年。
- 阻燃性高---产品含有氯元素, 离火自熄。
- 强度高---拉伸强度可达45Mpa, 常温下工作压力可达1.6Mpa。
- 安装方便---采用胶水粘接, 不需加工螺纹, 施工方便快捷。



适用场合

- | | |
|----------|----------|
| 自来水工程 | 海水输送 |
| 化工用管 | 灌溉、喷灌用管 |
| 纯水输送 | 食品加工液体输送 |
| 污水处理输送 | 电力通信用管 |
| 电镀废水处理用管 | |



UPVC管道温度对压力的折减系数

公称压力(PN)指管道输送20°C水的最大工作压力, 当输水温度不同时按下表给出的不同温度对压力的折减系数修正工作压力, 用折减系数乘以公称压力得到最大允许工作压力。

温度t/°C	折减系数
0≤t≤25	1
25≤t≤35	0.8
35≤t≤45	0.63



运输、储存堆放要求

- 管材管件在运输与装卸时, 不得抛摔、暴晒、重压和损伤。
- 管材应合理堆放, 高度不宜太高(≤2M), 以防重压变形, 且不得暴晒, 管材易弯曲。

公称尺寸对照表

公制 DIN	Φ	20	25	32	40	50	63	75	90	110	140	160	225	280	315	400
	DN	15	20	25	32	40	50	65	80	100	125	150	200	250	300	400
英制	Φ	21.3	26.7	33.4	42.1	48.2	60.3	73.0	88.9	114.3	141.3	168.3	219.1	273.1	323.9	
	inch	1/2"	3/4"	1"	1-1/4"	1-1/2"	2"	2-1/2"	3"	4"	5"	6"	8"	10"	12"	14"

UPVC管道支撑数据表

规格	Φ	20	25	32	40	50	63	75	90	110	140	160	225	280	315	400
支撑间距(M)	20°C	1.2	1.3	1.4	1.6	1.7	1.8	1.9	2.2	2.4	2.5	2.9	3.2	3.4	4.2	4.7
	50°C	0.8	1.0	1.1	1.2	1.2	1.3	1.3	1.5	1.8	1.8	2.0	2.2	2.4	3.7	4.0

注: 以上数据适用于流体介质密度为1.0g/cm³, 震动较小, 管路水平铺设, 若震动大, 间距要适当改小。

安装使用说明

- 管材切割:**
管材按要求尺寸用钢锯、电锯或管道切割机等工具截取所需管材, 切割时应保持两端垂直平衡, 以保证最大粘接面积。
- 去毛边倒角:**
利用锉刀或倒角工具将管内外壁的毛边去掉, 外端口倒角10°-15°, 便于管材插入管件。
- 试承插:**
用干净的棉布擦去管及管件接合面上的灰尘及水份, 检查管与管件的配合状况, 管材应能轻松插入管件的1/3到3/4深。
- 涂预粘胶:**
用一干净的毛刷(约为管径的一半)在管道外壁和管件内壁均匀涂抹清洗剂或预粘胶, 使粘胶表面渗透软化。(通常管径小可不用此步骤)
- 涂胶:**
用干净的毛刷在管道外壁和管件内壁均匀涂抹胶粘剂, 管道涂抹长度为管径的一半距离, 所涂的胶粘剂应保证连接后填满所有的空隙。(间隙大应多涂几次胶水)
- 组合粘结:**
涂完胶后, 应立即将管插入管件并旋转至安装所需的理想组合角度, 固定若干时间, 用棉布将溢出多余的胶水擦去, 以防过量软化粘接处, 影响强度。
- 每1Kg胶水可粘接数量表(见表一)**
- 更详细的胶水使用及粘接资料可登录本公司网站或来电索取。**

(表一)

管道直径Φ	20	25	32	50	63	90	110	160	225	280	315	400
接口数量	300	200	125	90	60	40	30	10	5	2-3	1-2	1

耐化学腐蚀资料表

耐化学腐蚀资料表

介质	UPVC(°C)			ABS(°C)			介质	UPVC(°C)			ABS(°C)		
	20	40	60	20	40	60		20	40	60	20	40	60
乙醛C ₂ H ₄ O	X	X	X	X	X	X	氢氧化钠NaOH	★	★	▲	★	★	★
乙酸CH ₃ COOH 10%	★	★	▲	★	★	▲	氯乙醇	X	X	X	X	X	X
乙酸CH ₃ COOH 50%	★	★	X	X	X	X	氯酸HClO ₃	★	★	▲	X	X	X
丙酮CH ₃ -CO-CH ₃	X	X	X	X	X	X	氯气Cl ₂	▲	▲	X	X	X	X
苯乙酮	X	X	X	X	X	X	氯水	▲	▲	X	▲	X	X
己二酸C ₆ H ₁₀ O ₄	★	★	X	X	X	X	氯苯	X	X	X	X	X	X
氯化铝AlCl ₃	★	★	★	★	★	★	氯仿CHCl ₃	X	X	X	X	X	X
硫酸铝Al ₂ (SO ₄) ₃	★	★	★	★	★	★	铬酸	▲	▲	X	X	X	X
氨气NH ₃	★	★	★	X	X	X	柠檬酸 10%	★	★	▲	★	★	★
乙酸铵CH ₃ COONH ₄	★	★	▲	X	X	X	椰子油	★	★	▲	X	X	X
碳酸铵(NH ₄) ₂ CO ₃	★	★	▲	★	★	★	玉米油	▲	X	X	▲	X	X
氯化铵CH ₃ Cl	★	★	▲	★	★	★	环己烷	X	X	X	X	X	X
氟化氢铵CH ₃ HF ₂	★	★	▲	X	X	X	环己酮	X	X	X	X	X	X
氢氧化铵NH ₄ OH	★	★	▲	★	★	▲	洗涤剂(洗衣粉)	★	★	▲	X	X	X
硝酸铵(NH ₄) ₂ SO ₄	★	★	▲	★	★	★	二氯乙酸	★	★	▲	X	X	X
硫酸铵(NH ₄) ₂ SO ₄	★	★	▲	★	★	★	二氯乙烯	X	X	X	X	X	X
硫化铵(NH ₄) ₂ S	★	★	▲	★	★	★	二甲胺	▲	X	X	X	X	X
戊醇	★	★	▲	X	X	X	二乙胺	▲	X	X	X	X	X
酒	★	★	★	▲	▲	▲	酒精乙醇	★	▲	▲	X	X	X
砷酸H ₃ AsO ₄	★	★	▲	★	★	★	乙二醇	★	★	★	★	★	★
苯甲醛	X	X	X	X	X	X	氟硅酸H ₂ SiF ₆	★	★	★	★	★	★
苯	X	X	X	X	X	X	甲醛HCHO	★	★	▲	★	★	★
汽油、柴油	★	★	▲	X	X	X	甲酸HCOOH	★	▲	▲	X	X	X
溴水	★	★	★	X	X	X	葡萄糖	★	★	★	★	★	★
丁二醇 10%	★	▲	▲	X	X	X	甘油	★	★	▲	★	★	▲
丁醇C ₄ H ₉ OH	★	★	▲	X	X	X	甘氨酸 10%	★	★	★	★	★	★
丁酸	★	X	X	X	X	X	己烷C ₆ H ₁₄	★	▲	▲	★	▲	▲
盐水、海水	★	★	★	★	★	★	氢溴酸HBr	★	★	▲	★	★	▲
氯化钙CaCl ₂	★	★	★	★	★	★	盐酸HCl 10%	★	★	▲	★	★	▲
氢氧化钙Ca(OH) ₂	★	★	★	★	★	★	盐酸HCl 30%	★	★	▲	▲	X	X
四氯化碳CCl ₄	X	X	X	X	X	X	氢氰酸HCN	★	★	▲	X	X	X
氢氧化钾KOH	★	★	▲	★	★	★	氢氟酸HF	★	X	X	X	X	X

A:★不侵蚀,使用良好 B:▲稍微侵蚀,可酌情使用 C:X侵蚀,不能使用

介质	UPVC(°C)			ABS(°C)			介质	UPVC(°C)			ABS(°C)		
	20	40	60	20	40	60		20	40	60	20	40	60
氯化氢气体HCl	★	★	▲	X	X	X	硝酸钾KNO ₃	★	★	★	★	★	★
双氧水H ₂ O ₂	★	★	▲	X	X	X	丙酸CH ₃ CH ₂ COOH	★	▲	X	X	X	X
硫化氢H ₂ S	★	★	▲	★	▲	X	硅油	★	▲	X	★	X	X
异丙醇	★	★	▲	X	X	X	乙酸钠CH ₃ COONa	★	★	★	★	★	★
乳酸 10%	★	▲	X	★	▲	X	碳酸氢钠NaHCO ₃	★	★	★	★	★	★
汞Hg	★	★	★	★	▲	X	碳酸钠Na ₂ CO ₃	★	★	★	★	★	★
甲醇CH ₃ OH	★	★	▲	X	X	X	溴化钠NaBr	★	★	★	★	★	★
乙酸甲酯	X	X	X	X	X	X	氯酸钠NaClO ₃	★	★	★	★	★	★
甲胺CH ₃ NH ₂	▲	X	X	X	X	X	亚氯酸钠NaClO ₂	▲	X	X	★	X	X
溴甲烷CH ₂ Br	X	X	X	X	X	X	次氯酸钠NaOCl	★	★	X	X	X	X
氯甲烷CH ₃ Cl	X	X	X	X	X	X	氟化钠NaF	★	★	★	★	★	★
二氯甲烷CH ₂ Cl ₂	X	X	X	X	X	X	氢氧化钠NaOH	★	★	★	★	★	★
牛奶	★	★	★	★	★	★	硝酸钠NaNO ₃	★	★	▲	★	★	★
硝酸HNO ₃ 10%	★	★	★	★	▲	X	草酸钠Na ₂ C ₂ O ₄	★	★	★	★	★	★
硝酸HNO ₃ 40%	★	★	▲	★	★	X	硫酸钠Na ₂ SO ₄	★	★	▲	★	★	★
硝酸HNO ₃ 60%	▲	▲	X	X	X	X	硫化钠Na ₂ S	★	★	▲	★	★	★
橄榄油	★	★	★	★	★	★	硬脂酸C ₁₇ H ₃₅ COOH	★	★	★	★	★	★
草酸C ₂ H ₂ O ₄	★	★	★	★	★	★	硫磺S	▲	X	X	X	X	X
臭氧O ₃	★	★	▲	X	X	X	二氧化硫SO ₂	★	★	▲	X	X	X
棕榈酸	★	▲	▲	★	▲	▲	三氧化硫SO ₃	X	X	X	X	X	X
石蜡油	★	★	★	★	★	★	硫酸H ₂ SO ₄ 40%	★	★	▲	★	▲	X
高氯酸HClO ₄ 10%	★	★	▲	★	★	★	硫酸H ₂ SO ₄ 90%	★	★	▲	X	X	X
高氯酸HClO ₄ 70%	▲	X	X	X	X	X	硫酸H ₂ SO ₄ 98%	★	X	X	X	X	X
磷酸H ₃ PO ₄	★	★	▲	★	★	▲	亚硫酸H ₂ SO ₃	★	★	★	★	★	★
邻苯二甲酸	★	▲	X	X	X	X	四氯化乙烷	X	X	X	X	X	X
重铬酸钾K ₂ CrO ₇	★	★	▲	★	★	★	四氢呋喃	X	X	X	X	X	X
硼酸钾K ₂ BO ₃	★	★	★	★	★	★	四氯化萘	X	X	X	X	X	X
溴酸钾KBrO ₃	★	★	★	★	★	★	甲苯	X	X	X	X	X	X
溴化钾KBr	★	★	★	★	★	★	三氯乙烯	X	X	X	X	X	X
氯酸钾KClO ₃	★	★	★	★	★	★	三乙醇胺	▲	X	X	★	X	X
氰化钾KCN	★	★	★	★	★	★	三乙胺	X	X	X	X	X	X
碘化钾KI	★	★	★	★	★	★	尿素	★	★	▲	★	★	★
高锰酸钾KMnO ₄	★	★	★	★	★	★	醋	★	★	★	★	★	★

A:★不侵蚀,使用良好 B:▲稍微侵蚀,可酌情使用 C:X侵蚀,不能使用