

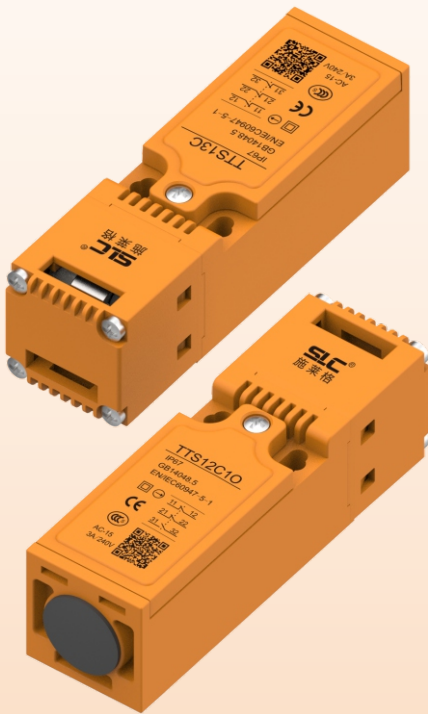

TTS1 series reed interlock safety switch



> Functional features

Reed interlock safety switches are the most commonly used door interlock technology. They use a key mounted at the opening of the switch body to detect the movement of the protective door. Due to their small and lightweight form factor and variety of contact configurations, reed interlock switches are often the lowest cost solution. Moreover, thanks to the use of flexible keys, the alignment tolerance is increased, so it can be used in a wide range of applications.

The TTS1 reed interlock safety switch allows the switch head to be rotated 4 times at a 90-degree angle, allowing the key to be inserted into the switch in 8 different positions, providing a variety of different options for how the switch works and how it can be installed on the protective door. This increases the flexibility of the switch and makes it suitable for use on a variety of doors.

> Model description

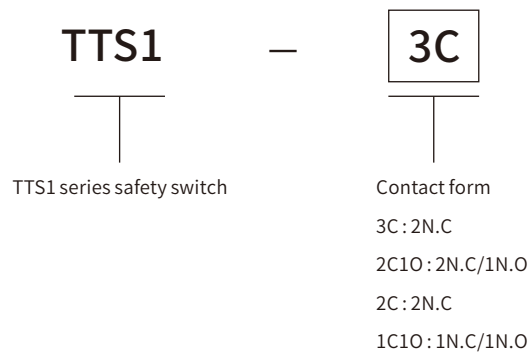

> Selection guide

Model	Specifi cation	Order number	Image
TTS13C	3NC	LOT1033220L30	
TTS12C10	2NC/1NO	LOT1033220L21	
TTS1K1	Bend the key	LOTTTS1-L1	
TTS1K2※	Straight key	LOTTTS1-B1	
TMLK1	Flexible key	LOT50551842K1	
TMLG1	Guide	LOT36303425G1	
WJ-16015	M16×1.5 nylon waterproof joint	LOTWJ16015	



Technical parameters

Security level	
Standard	EN60947-5-1/GB/T14048.5
Security classification	The dual-channel E-lock is suitable for either Class 3 or Class 4 systems
B10D	A million times
Authentication	CE CCC(CQC)
Mechanical life	More than a million times
Electrical life	More than a million times
Electrical characteristics	
Rated insulation withstand voltage(Ui)	300V
Protection against electric shock	Class II (Double insulation)
Pollution degree (use environment)	3 (EN60947-5-1)
Impulse withstand voltage (EN60947-5-1)	2.5kV
Contact contact resistance	Below 25mΩ
Insulation resistance	More than 100mΩ
Rated open heating current (Ith)	10A
Conditional short-circuit current	100A
Contact spacing	2.5mm
Operating characteristics	
Minimum power	15N
Maximum execution speed	160mm/s

Maximum execution frequency	2 cycles/sec	
Minimum switching house current at a specific voltage	5mA@5VDC	
Contact type		
Safety contacts	2-way NC	3-wayNC
Auxiliary contacts	1-wayNO	-
Usage type		
Load category	AC-15	DC-13
Rated operating voltage	240V	24V
Rated operating current	3A	2A
Environment		
Enclosure rating	IP65	
Operating temperature	-20~+80°C	
Usage environment	Below 95%	
Vibration resistant	10~55Hz unilateral amplitude 0.75mm	
Stamping resistant	300m/s ²	
Material		
weight	About 200g	
Color	Dark yellow	
Housing material	UL certified thermoplastics	
Actuator material	SUS304	

Contact description

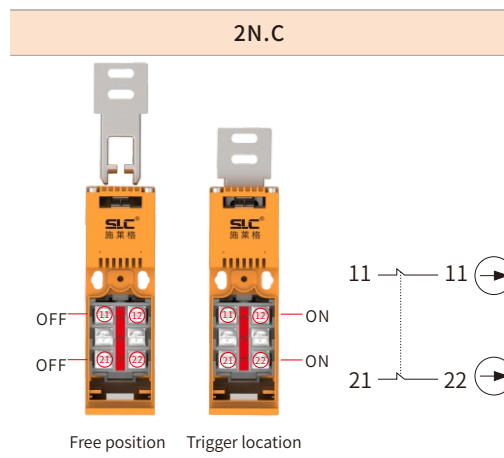
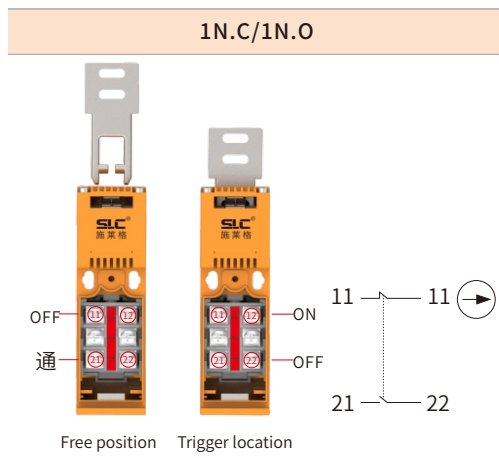
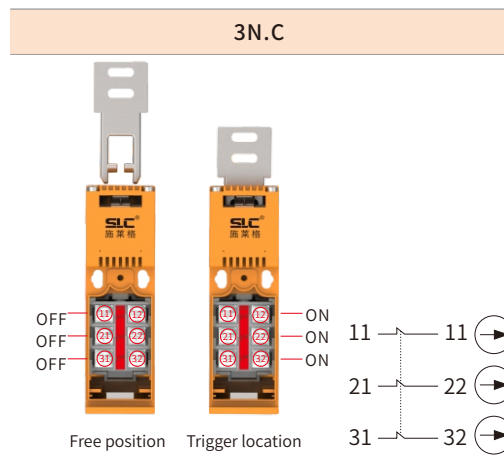
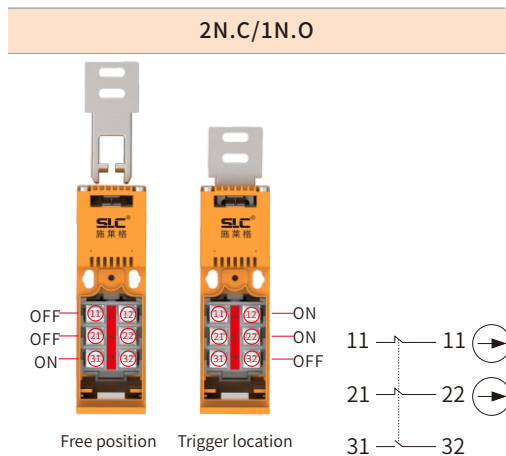

Force disconnect, force open contact

Forced disconnection refers to the separation of contacts by the forced movement of the actuating element (trigger element). A switch contact with this switching characteristic is called a forced opening contact. The forced free position trigger position disconnect contact is a normally closed contact, marked with the symbol \ominus . In addition, switches with a forced disconnect function must meet the requirements of Annex K of the standard EN 60947-5-1.

TTS1 SERIES REED INTERLOCK SAFETY SWITCH

Toggle the status travel chart

TTS1K2 trigger contact travel diagram

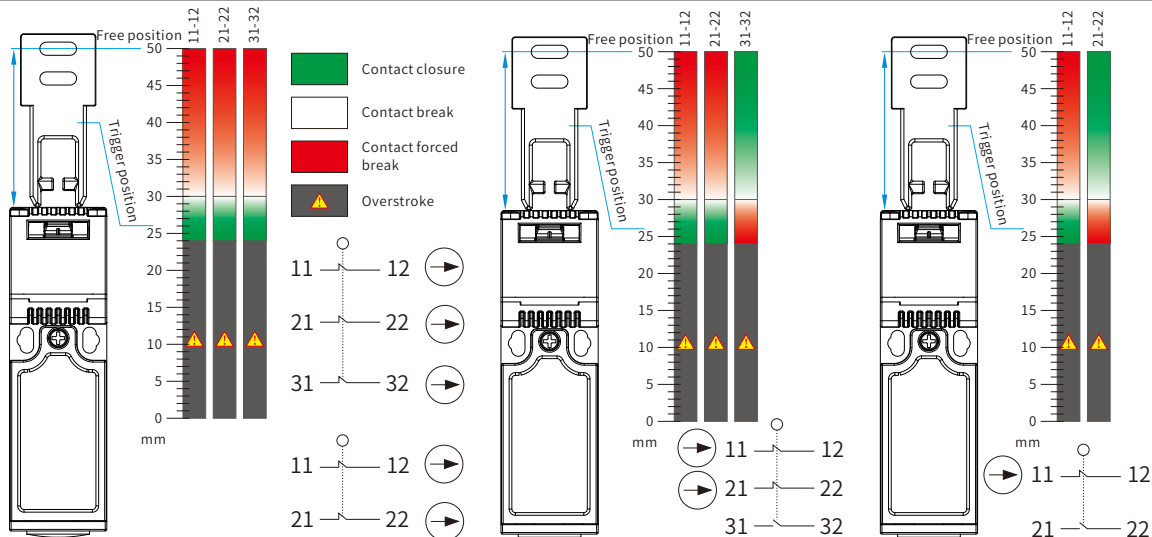

TTS1K1 trigger contact travel diagram

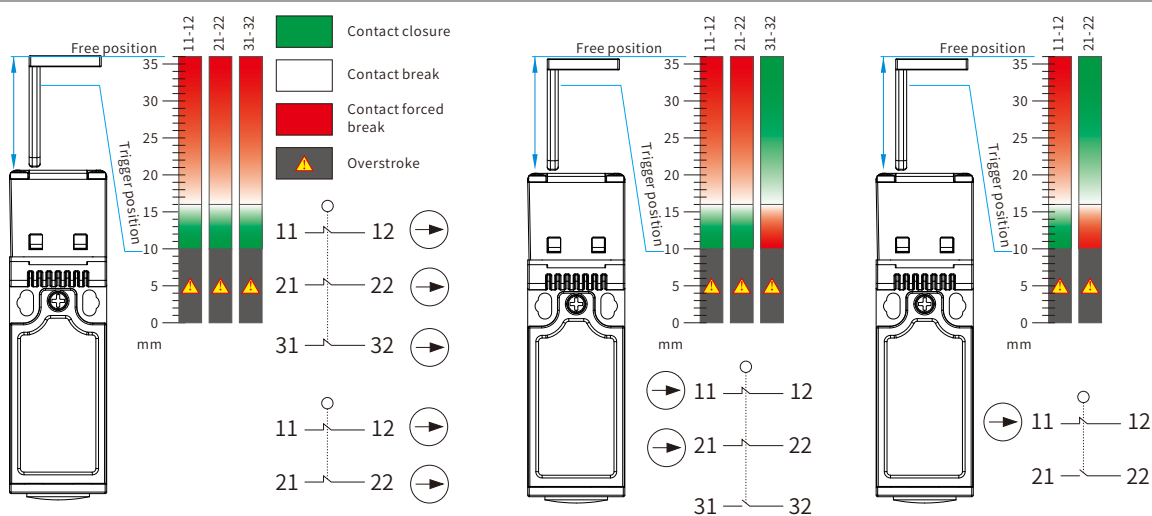

TMLK1 trigger contact travel diagram

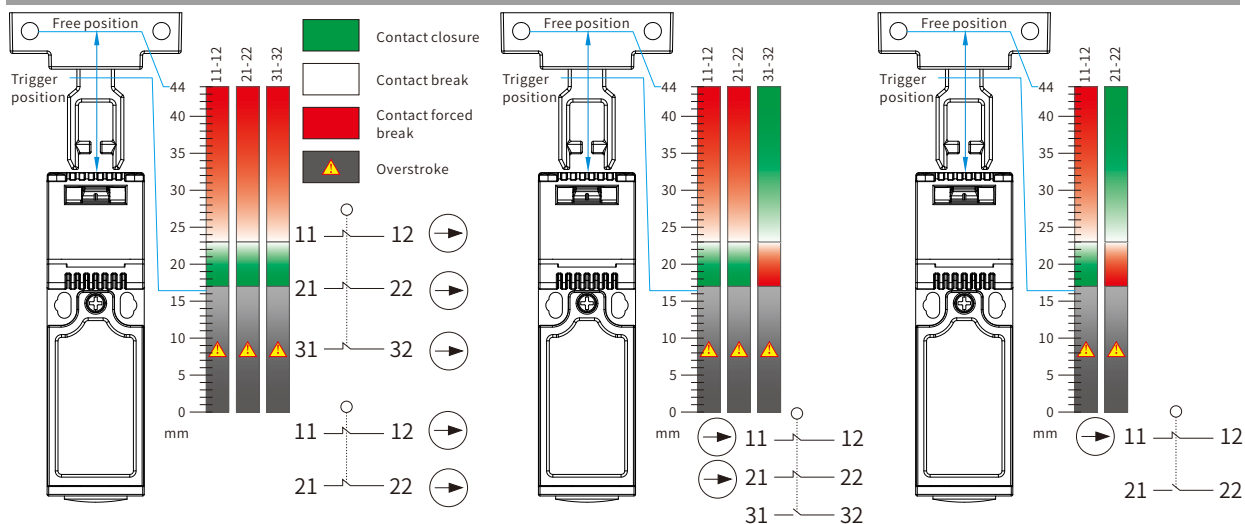

※ Depending on the product configuration and manufacturing process, the actual product size and weight may vary, please refer to the actual product

Contact state closure and disconnection relationship

For detailed switching status of the product, please refer to the status switching related content.

When the drive element (trigger element) is in a free position, the safety contact \ominus is disconnected;

When the drive element (trigger element) is in the trigger position, the safety contact \ominus is closed;

Feature description

The safety switch monitors the position of the movable safety guard.

When the drive element moves from the actuating position to the free position, the safety contact \ominus is triggered. During this process, the safety contact has been completely disconnected.

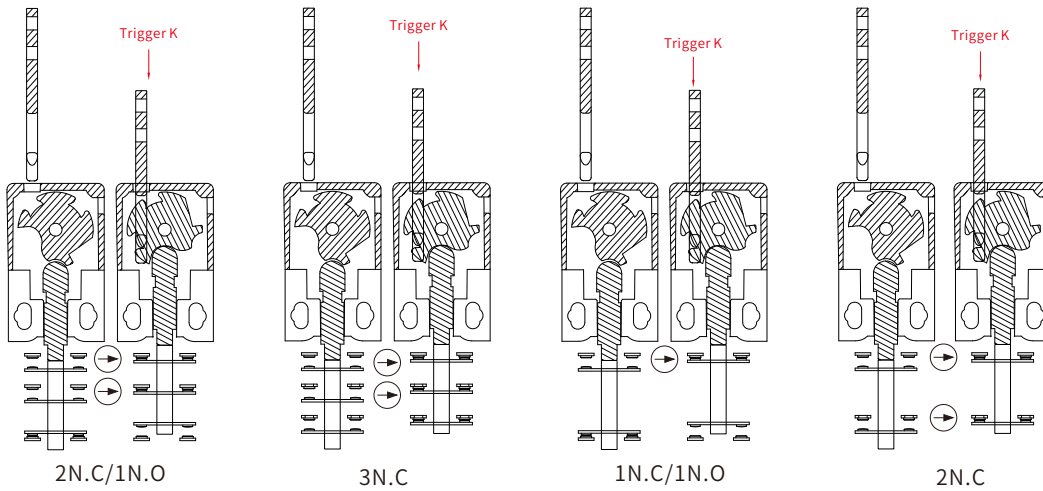

Execution key size and minimum active distance (mm)

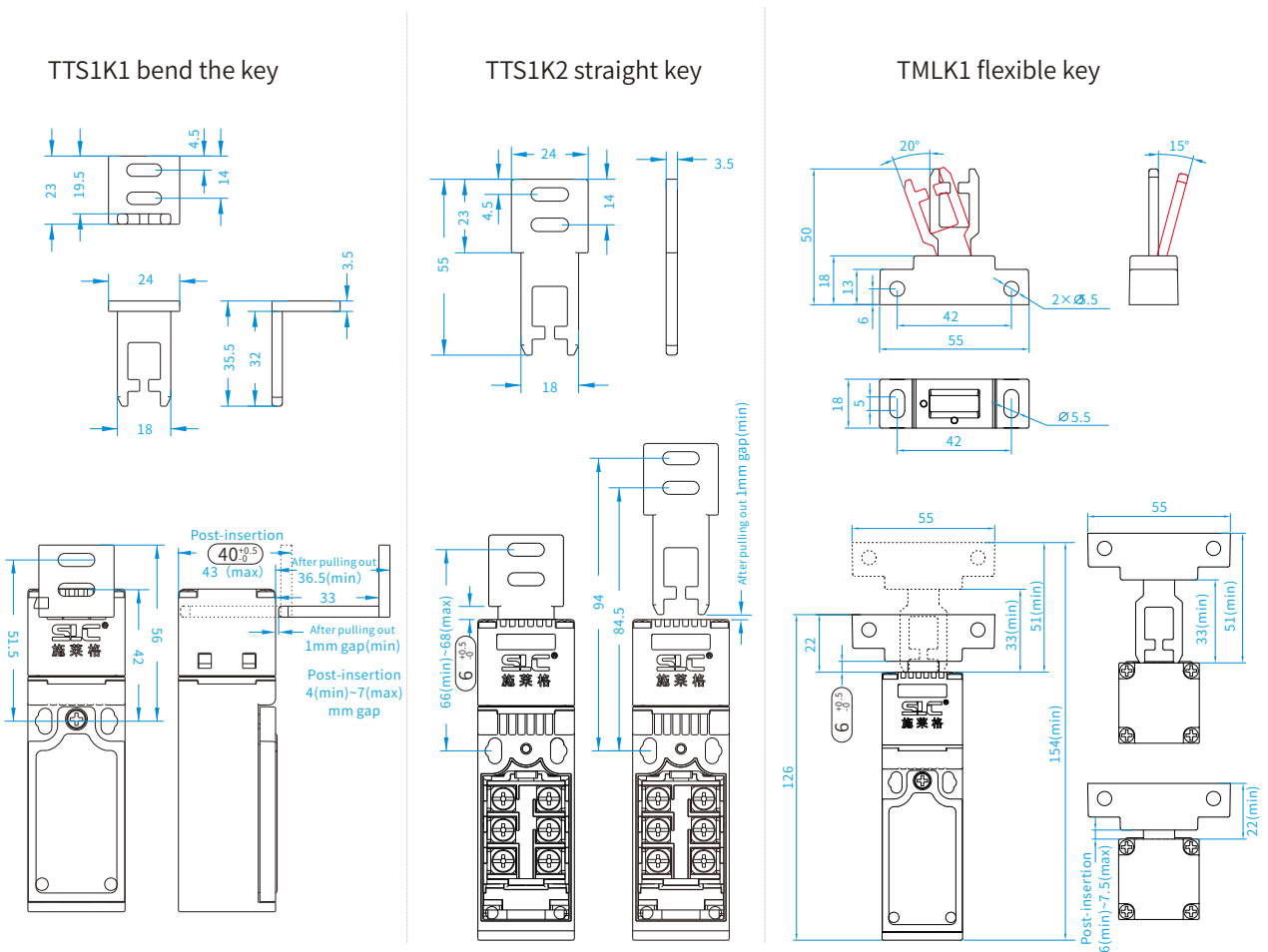

※ Depending on the product configuration and manufacturing process, the actual product size and weight may vary, please refer to the actual product

Overall dimension(mm)

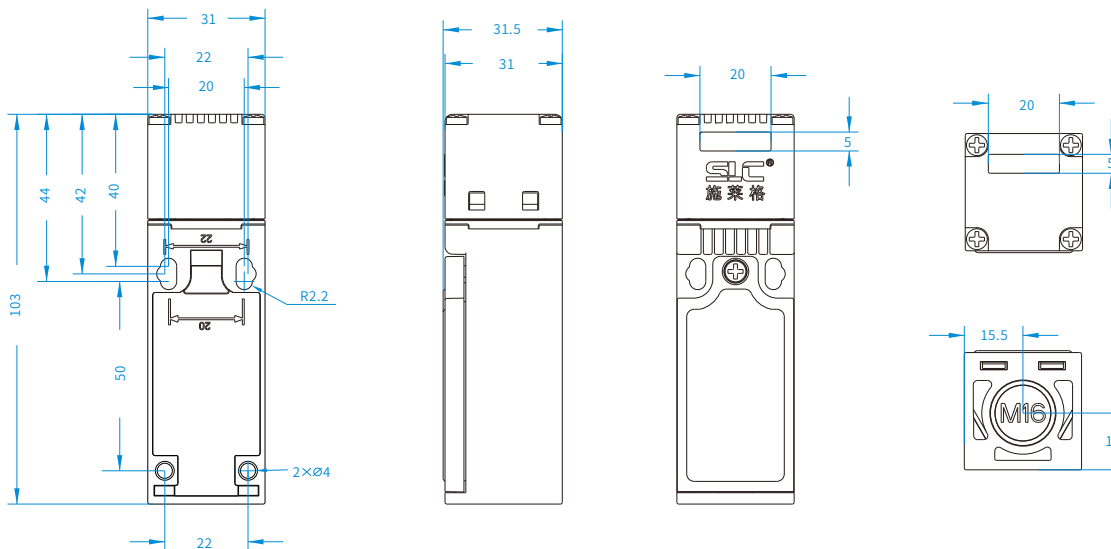

Electrical connection

The following information applies only to crystalline production with cable entry:

1. Remove the screw from the operating head and adjust the direction of operation;
2. Set the rotating operating head and set the required direction;
3. Tighten the screw with a torque of 0.6Nm.
4. Open the safety switch housing;
5. When using the safety switch as an interlock device for personnel protection, at least one safety system must be used (⊕), please refer to the contact description for safety positive distribution;
6. Connect and tighten the terminal screws with 0.5Nm torque;
7. Check whether the cable inlet is sealed;
8. Close the switch cover and tighten the screws in place (tightening torque 0.6Nm)



Warn

- ◆ When adjusting the head orientation, it is necessary to ensure that the direction of the linkage rod is relative to the head as shown in the figure below;
- ◆ Incorrect connection will cause loss of security functions;
- ◆ Only secure contacts (⊕) provide secure connection function;

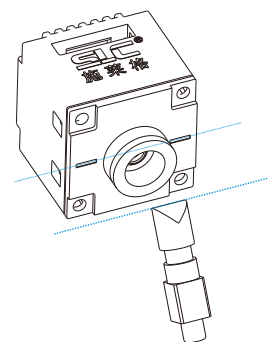
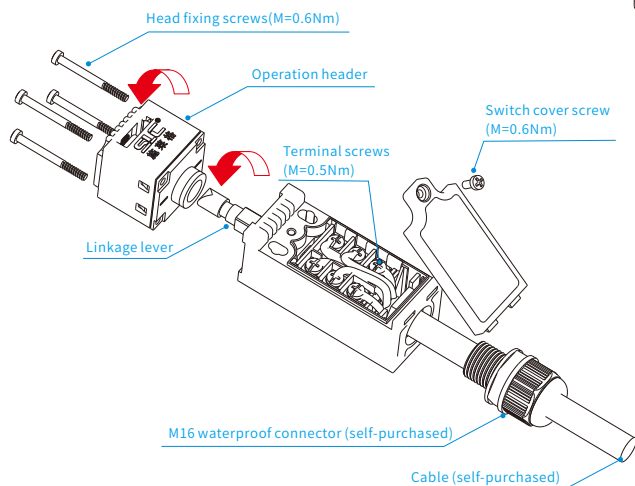
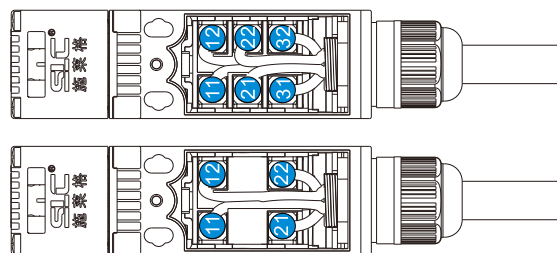

Before use, please make sure that the orientation is consistent with the illustration

Application examples

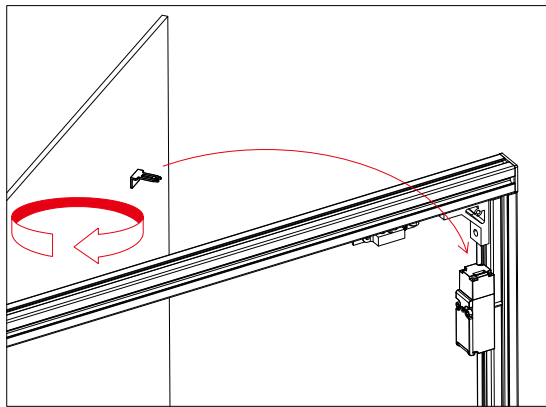
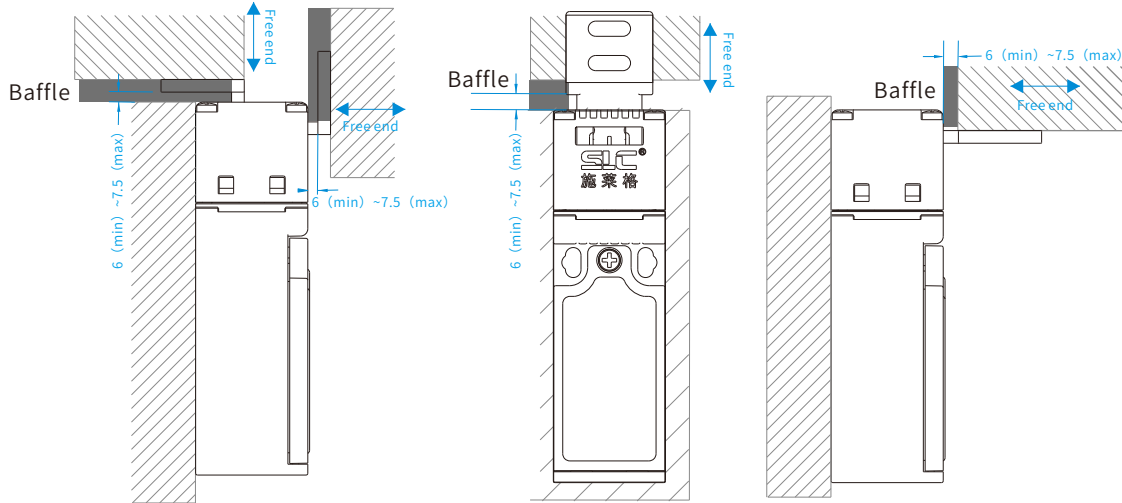

Baffle or cam limits should be used, and the lock body is not a substitute for baffle.

The above installation needs to be mechanically fixed, and it must be avoided that the owner will loosen itself. In addition, it must be ensured that cams and baffle can only be installed in the correct position. To prevent alterations to the switch, safety screws can also be used when installing safety switches and baffle.

Revolving door installation dimensions

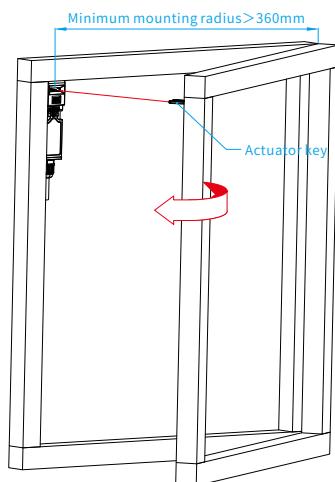

The minimum installation radius is measured from the center of the actuator (actuation key) insert of the safety switch (safety interlock) to the center of the revolving door rotary axis.

Using correctly

The TTS1 series safety switches are interlocking devices without guard locking (with safety function). Actuators to encode (e.g. dongles, RFID, etc.). In combination with movable safety guards and machine controls, this safety component prevents dangerous machine functions from occurring when the safety guards are opened. If the safety guard is turned on during the dangerous machine function, a stop command is triggered.

This means:

- ▶ Start commands that cause dangerous host functions can only be initiated when the safety guard is turned off.
- ▶ Opening the safety guard triggers a stop command.
- ▶ Closing the safety guard must not lead to the automatic start of dangerous machine functions, a separate start command must be issued.

For exceptions, see EN ISO 12100 or the relevant C standard.

- ▶ The TTS1 series can be used as a safe position encoder.

Before using the TTS1 series products, the following standards must be met to assess the risk of the machine:

- ▶ EN ISO 13849-1, Safety of machinery – Safety-related components of control systems – Part 1: General principles for design.
- ▶ EN ISO 12100, general principles for the safety of machinery by design, risk assessment and risk reduction.
- ▶ IEC62061, machinery safety - functional safety of electrical, electronic and programmable electronic control systems.

Proper use includes compliance with the relevant requirements for installation and operation, in particular based on the following standards:

- ▶ EN ISO 13849-1, safety of machinery – safety-related components of control systems – part 1: general principles for design.
- ▶ EN ISO 14119, safety of machinery. Interlocking devices related to guards, design and selection principles.
- ▶ EN 60204-1, safety of machinery – electrical equipment for machinery.

Important:

- ▶ The user is responsible for the correct integration of the device into the overall system for safety. Therefore, the entire system must be verified, for example by setting up the dongle according to EN ISO 13849-2 requirements.
- ▶ If the performance level (PL) is determined using the simplified method of EN ISO 13849-1:2015 section 6.3, the PL may be reduced if multiple devices are connected in series.
- ▶ In some cases, the logical series connection of the safety contacts can reach PLd. For more information about this issue, see IS0TR24119.
- ▶ If the product comes with a product data sheet, the information on the data sheet is appropriate for cases where it does not correspond to the operating instructions.

Functional test

After installation and after each failure, check that the device functions correctly.

Follow these steps:

▶ Mechanical energy test

The actuator must be easy to move, close the safety guard several times to check the function.

▶ Electrical function test

1. Turns on the working power.
 2. Close all safety guards, **the machine must not start automatically.**
 3. Start the machine function.
 4. Open the safety guard, **the machine must be closed, as long as the safety guard is turned on, the machine cannot be started.**
- Repeat steps 2-4 above for each safety guard.

 Warn	<ul style="list-style-type: none"> ◆ Failures may occur during the functional test and fatal injuries may occur, please ensure that there are no personnel in the danger zone before conducting the functional test. ◆ Please observe effective accident prevention regulations.
--	--

Inspection and maintenance

The following items must be checked to ensure trouble-free

- ▶ long-term operation;
- ▶ Correct switch function;
- ▶ Install correctly;
- ▶ All parts are free of damage, serious contamination, dirt.;
- ▶ Cable entry is worn and sealed;
- ▶ The cable connection is moved or the plug connector is loose.

 Warn	<p>Loss of safety functions poses a risk of serious injury</p> <ul style="list-style-type: none"> ◆ If damage or wear is found, the entire switch must be replaced. Replacement of individual parts or assemblies is not permitted. ◆ After each failure, periodically check that the equipment is working properly. <p>For inspection frequencies please refer to EN ISO14119:2013, section 8.2.</p>
--	--

Safety precautions

- ▶ Improper installation and inappropriate environment can cause damage to the device.
- ▶ Safety switches and actuators must not be used as end stops.
- ▶ For information on tightening safety switches and brakes, observe EN ISO14119:2013 sections 5.2 and 5.3.
- ▶ Please observe EN ISO14119: 2013 section 7 for information on reducing the possibility of bypass interlocks.
- ▶ Protect the switch head from damage.
- ▶ The stop (end stop) must be installed according to the  size of the stop.

 Warn	<p>Life-threatening due to improper installation or bypass (tampering).</p> <ul style="list-style-type: none"> ◆ Safety components with personal protection function. Safety components must not be bypassed, turned off, removed or otherwise rendered ineffective. ◆ Regarding this, a special reminder is requested to reduce the possibility of bypass in accordance with EN ISO 14119:2013 section 7.
--	--